



Elsinore Valley Municipal Water District

RECYCLED WATER SYSTEM MASTER PLAN

FINAL | February 2024





**ELSINORE
VALLEY**

MUNICIPAL WATER DISTRICT

Elsinore Valley Municipal Water District

RECYCLED WATER SYSTEM MASTER PLAN

FINAL | February 2024



Contents

Executive Summary

ES.1 Recycled Water Systems and Recommendations	ES-1
ES.1.1 Wildomar System	ES-2
ES.1.2 Railroad Canyon System	ES-5
ES.1.3 Horsethief System	ES-6
ES.1.4 Regional System	ES-8
ES.2 Capital Improvement Program	ES-11

Chapter 1 - Introduction

1.1 Project Background	1-1
1.2 Project Objectives	1-2
1.3 Scope of Work	1-2
1.4 Authorization	1-3
1.5 Acknowledgements	1-3
1.6 Project Staff	1-4
1.7 Master Plan Outline	1-4

Chapter 2 - Study Area and Land Use

2.1 Study Area	2-1
2.1.1 Service Area Population	2-2
2.1.2 Recycled Water System Overview	2-5
2.2 Land Use	2-6
2.2.1 Planned Developments	2-8

Chapter 3 - Recycled Water Production and Demand

3.1 Wildomar Recycled Water Supply and Demand	3-1
3.2 Wildomar Recycled Water Supply Source	3-1
3.2.1 Recycled Water Customers	3-3
3.2.2 Future Recycled Water Demand	3-3
3.2.3 Seasonal Demand Variability	3-8
3.2.4 Maximum Day Demand and Peak Hour Demand	3-15

3.3 Railroad Canyon Recycled Water Supply and Demand	3-19
3.3.1 Recycled Water Supply Source	3-19
3.3.2 Recycled Water Customers	3-20
3.3.3 Available Supply and Historical Demand	3-20
3.3.4 Future Recycled Water Demand	3-24
3.3.5 Seasonal Demand Variability	3-24
3.3.6 Maximum Day Demand and Peak Hour Demand	3-29
3.4 Horsethief Canyon Recycled Water Supply and Demand	3-30
3.4.1 Recycled Water Supply Source	3-30
3.4.2 Recycled Water Customers	3-30
3.4.3 Available Supply and Historical Demand	3-31
3.4.4 Future Recycled Water Demand	3-31
3.4.5 Seasonal Demand Variability	3-34
3.4.6 Maximum Day Demand and Peak Hour Demand	3-39
3.5 Regional Recycled Water Supply and Demand	3-40
3.5.1 Regional Recycled Water Supply Source	3-40
3.5.2 Available Supply and Historical Demand	3-40
3.5.3 Future Recycled Water Demand	3-43
3.5.4 Projected Supply and Demand Analysis	3-48
Chapter 4 - Description of Existing Systems	
4.1 Introduction	4-1
4.2 Wildomar System	4-2
4.2.1 Wildomar Sources of Supply	4-2
4.2.2 Wildomar Demands	4-2
4.2.3 Wildomar Turnouts	4-7
4.2.4 Wildomar Distribution Network	4-7
4.2.5 Wildomar Operations	4-8
4.3 Railroad Canyon System	4-8
4.3.1 Railroad Canyon Sources of Supply	4-8
4.3.2 Railroad Canyon Demands	4-11
4.3.3 Railroad Canyon Pump Stations	4-11
4.3.4 Railroad Canyon Storage	4-12

4.3.5 Railroad Canyon Distribution Network	4-13
4.3.6 Railroad Canyon Pressure Zones	4-15
4.3.7 Railroad Canyon Operations	4-15
4.4 Horsethief System	4-16
4.4.1 Horsethief Source of Supply	4-16
4.4.2 Horsethief Demands	4-19
4.4.3 Horsethief Pump Stations	4-19
4.4.4 Horsethief Canyon Storage	4-20
4.4.5 Horsethief Canyon Distribution Network	4-20
4.4.6 Horsethief Pressure Zones	4-21
4.4.7 Horsethief Operations	4-22
4.5 Regional System	4-22
4.5.1 Regional Source of Supply	4-25
4.5.2 Regional Demands	4-25
4.5.3 Regional Distribution Network	4-25
4.5.4 Regional Operations	4-26

Chapter 5 - Recycled Water System Model Development

5.1 Introduction	5-1
5.2 Hydraulic Model Development	5-1
5.2.1 Data Collection	5-2
5.2.2 Model Coordinate System	5-2
5.2.3 Pipelines	5-2
5.2.4 Junctions	5-3
5.2.5 Storage Tanks	5-3
5.2.6 Booster Pumps	5-3
5.2.7 Water Reclamation Facilities and Ponds	5-4
5.2.8 Facility Elevation Data	5-4
5.2.9 Demand Allocation	5-5
5.2.10 Diurnal Pattern	5-5
5.3 Model Calibration	5-7

Chapter 6 - Planning and Evaluation Criteria

6.1 Design Criteria	6-1
6.1.1 System Pressures	6-1
6.1.2 Pipeline Velocities	6-2
6.1.3 Storage	6-2
6.1.4 Pumping Capacity	6-2

Chapter 7 - Existing System Analysis

7.1 Wildomar System Existing System Analysis	7-1
7.1.1 Booster Pump Capacity Evaluation	7-2
7.1.2 Storage Capacity Evaluation	7-2
7.1.3 System Pressure and Velocities	7-2
7.1.4 Recommendations	7-2
7.2 Railroad Canyon System Existing System Analysis	7-5
7.2.1 Booster Pump Capacity Evaluation	7-5
7.2.2 Storage Capacity Evaluation	7-6
7.2.3 System Pressure and Velocities	7-9
7.2.4 Recommendations	7-10
7.3 Horsethief Canyon System Existing System Analysis	7-10
7.3.1 Booster Pump Capacity Evaluation	7-13
7.3.2 Storage Capacity Evaluation	7-14
7.3.3 System Pressure and Velocities	7-17
7.3.4 Recommendations	7-18
7.4 Regional System Existing System Analysis	7-18
7.4.1 Booster Pump Capacity Evaluation	7-18
7.4.2 Storage Capacity Evaluation	7-18
7.4.3 System Pressure and Velocities	7-18
7.4.4 Recommendations	7-18
7.5 Pipeline and Facility Replacement Plans	7-21
7.5.1 Pipeline Replacement Plan	7-21
7.5.2 Reservoir Replacement Plan	7-21
7.5.3 Pump Replacement Plan	7-22

Chapter 8 - Future System Analysis

8.1 Wildomar System Future System Analysis	8-1
8.1.1 Potential Wildomar System Projects	8-2
8.1.2 Required Booster Pump Capacity	8-6
8.1.3 Required Storage Capacity	8-6
8.1.4 Required Pipelines	8-6
8.1.5 Recommendations	8-7
8.2 Railroad Canyon System Future System Analysis	8-7
8.2.1 Potential Recycled Water Customer	8-7
8.2.2 Required Booster Pump Capacity	8-8
8.2.3 Required Storage Capacity Evaluation	8-8
8.2.4 Required Pipelines	8-8
8.2.5 Recommendations	8-8
8.3 Horsethief System Future System Analysis	8-11
8.3.1 Potential Recycled Water Projects	8-11
8.3.2 Required Booster Pump Capacity	8-11
8.3.3 Required Storage Capacity	8-14
8.3.4 Required Transmission Pipelines	8-19
8.3.5 Recommendations	8-19
8.4 Regional System Future System Analysis	8-19
8.4.1 Potential Regional System Projects	8-19
8.4.2 Potable Reuse	8-20
8.4.3 Non-Potable Reuse	8-27
8.4.4 Recommendations	8-33

Chapter 9 - Capital Improvement Plan

9.1 Introduction	9-1
9.2 Phasing	9-1
9.3 Cost Estimating Basis	9-2
9.4 Recommended Improvement Program	9-4
9.4.1 Age Based Capital Improvement Projects	9-4
9.4.2 Capacity Based Capital Improvement Projects	9-4
9.4.3 Potential Future Growth-Related Capital Improvement Projects	9-4

9.4.4 CIP Projects and Costs by System	9-5
9.4.5 CIP Projects by Phase	9-10
9.5 Summary	9-19

Appendices

Appendix A	References
Appendix B	Recycled Water Agreements
Appendix C	Full List of Planned Developments Tracked by EVMWD
Appendix D	Diurnal Patterns for Customers Based on AMI Data
Appendix E	Non-Potable Reuse Projects
Appendix F	CIP Projects Summary Sheets
Appendix G	Non-CIP Projects Summary Sheets

Tables

Table ES.1	RW System CIP Cost Summary by System and Phase	ES-11
Table ES.2	RW System CIP Cost Summary by Existing and Future Users	ES-12
Table 2.1	EVMWD Service Area Population Projection	2-2
Table 2.2	Land Use Designations	2-6
Table 3.1	Wildomar Southern Division Sewershed Contribution to Santa Rosa WRF	3-2
Table 3.2	Wildomar RW Supply Sources	3-3
Table 3.3	RW Use Percentages by Billing Category for Existing Potable Customers	3-4
Table 3.4	RW Use Factors by Planned Development Type	3-5
Table 3.5	Wildomar Potential RW Customers	3-6
Table 3.6	Evapotranspiration Demand for Back Basin Wetlands	3-8
Table 3.7	Existing and Projected RW Demands for Wildomar Area	3-14
Table 3.8	Wildomar MDD:ADD PF by Year	3-15
Table 3.9	Wildomar PHD:MDD PF by Turnout	3-18
Table 3.10	Railroad Canyon RW Supply Sources	3-19
Table 3.11	2017-2021 Average Historical Monthly Demands	3-22
Table 3.12	Railroad Canyon Potential RW Customer	3-24
Table 3.13	Existing and Projected RW Demands for Railroad Canyon Area	3-27
Table 3.14	2021 Cottonwood (Canyon Hills) MDD:ADD PF	3-29
Table 3.15	Railroad Canyon PHD:MDD PF	3-30

Table 3.16	Horsethief RW Supply Sources	3-30
Table 3.17	2017-2021 Horsethief Average Supply and Demand by Month	3-32
Table 3.18	RW Demands of Horsethief Canyon Potential Non-Potable Expansion Customers	3-33
Table 3.19	Existing and Projected RW Demands for Horsethief Area	3-37
Table 3.20	Horsethief PHD:MDD PF	3-40
Table 3.21	Regional RW Supply Source	3-40
Table 3.22	2017-2021 Average Monthly Regional WRF RW Production and Discharge	3-42
Table 3.23	Projected Regional WRF Influent Flow	3-43
Table 3.24	Regional Potential Non-Potable Expansion Customers	3-43
Table 4.1	Summary of RW Distribution Components	4-1
Table 4.2	Wildomar Pipe Length by Diameter and Age	4-7
Table 4.3	Railroad Canyon Pumps	4-12
Table 4.4	Railroad Canyon Reservoirs and Storage Ponds	4-13
Table 4.5	Railroad Canyon Pipe Length by Diameter	4-14
Table 4.6	Horsethief Canyon Booster Pumps (at Horsethief Canyon WRF and the MRPS)	4-19
Table 4.7	Horsethief Canyon Storage and Excess Wet Weather Discharge	4-20
Table 4.8	Horsethief Canyon RW Pipe Length by Diameter and Age	4-21
Table 4.9	Regional Pipe Length by Diameter	4-26
Table 5.1	Elevation Range for RW Systems	5-5
Table 6.1	RW System Evaluation Criteria	6-1
Table 7.1	Railroad Canyon WRF System Capacity Evaluation	7-6
Table 7.2	Horsethief System Booster Pump Capacity Evaluation	7-14
Table 7.3	Age Based Booster Replacement Recommended Phasing	7-22
Table 8.1	Wildomar Project 1 - Potential Demand Summary	8-3
Table 8.2	Wildomar Project 1 - Size and Length of Pipelines	8-3
Table 8.3	Wildomar Project 2 - Demand Summary	8-4
Table 8.4	Wildomar Project 2 - Size and Length of Pipelines	8-4
Table 8.5	Wildomar Project 3 - Demand Summary	8-4
Table 8.6	Wildomar Project 3 - Size and Length of Pipelines	8-4
Table 8.7	Wildomar Project 4 - Demand Summary	8-5
Table 8.8	Wildomar Project 4 - Size and Length of Pipelines	8-5

Table 8.9	Wildomar Project 5 - Demand Summary	8-5
Table 8.10	Wildomar Project 5 - Size and Length of Pipelines	8-6
Table 8.11	Wildomar Potential Projects - Size and Length of Pipelines by Project	8-7
Table 8.12	Wildomar Potential Projects - Size and Length of Pipelines Summary	8-7
Table 8.13	Future Horsethief RW Demands	8-11
Table 8.14	Mid-Term Booster Pump Station Analysis for Horsethief System	8-13
Table 8.15	Long-Term Booster Pump Station Analysis for Horsethief System	8-13
Table 8.16	Horsethief Required Pipelines	8-19
Table 8.17	Regional Project 1 - Potential Demands	8-27
Table 8.18	Regional Project 2 - Potential Demands	8-28
Table 8.19	Regional Project 3 - Potential Demands	8-28
Table 8.20	Booster Pump Stations for Regional NPR System	8-28
Table 8.21	Regional Project 1 - Size and Length of Pipelines	8-30
Table 8.22	Regional Project 2 - Size and Length of Pipelines	8-30
Table 8.23	Regional Project 3 - Size and Length of Pipelines	8-30
Table 8.24	Regional Potential Projects - Size and Length of Pipelines by Project	8-33
Table 8.25	Regional Potential Projects - Size and Length of Pipelines	8-33
Table 9.1	Pipeline Unit Costs	9-2
Table 9.2	Storage Tank Costs (2023 Dollars)	9-3
Table 9.3	Booster Pump Replacement Costs (2023 Dollars)	9-3
Table 9.4	Booster Pump Station Costs (2023 Dollars)	9-3
Table 9.5	Typical Useful Life of Assets	9-4
Table 9.6	Railroad Canyon Pump Replacement Projects Cost	9-6
Table 9.7	Horsethief Pump Station Age Replacement Cost	9-6
Table 9.8	Horsethief CIP Projects Cost for Capacity Based Improvements	9-9
Table 9.9	Horsethief CIP Projects Cost to Address Existing Deficiencies	9-9
Table 9.10	Regional IPR Projects Cost	9-10
Table 9.11	RW System CIP Cost Summary by Phase and Project Type	9-15
Table 9.12	RW System CIP Cost Summary by Existing and Future Users	9-15
Table 9.13	RW System CIP Cost Summary by System by Phase	9-18

Figures

Figure ES.1	RW System Overview	ES-3
Figure ES.2	Supply and Demand Balance in Wildomar System	ES-5
Figure ES.3	Supply and Demand Balance in Horsethief System for Year 2030	ES-7
Figure ES.4	CIP Overview	ES-9
Figure ES.5	Projected Supply and Demand Balance for Regional WRF	ES-11
Figure ES.6	CIP by System and Phase	ES-12
Figure ES.7	CIP by Facility Type	ES-13
Figure 2.1	EVMWD Service Area	2-3
Figure 2.2	Service Area Land Use	2-9
Figure 3.1	Wildomar Southern Division Sewershed Contribution to Santa Rosa WRF	3-2
Figure 3.2	Future RW System Demand	3-9
Figure 3.3	Future RW System Demand - Wildomar	3-11
Figure 3.4	Projected RW Demands Based on Five Year Historical Maximum Demand by Month	3-13
Figure 3.5	Diurnal PFs of Turnout No. 1 for Wildomar Service Area	3-16
Figure 3.6	Diurnal PFs of Turnout No. 2A for Wildomar Service Area	3-16
Figure 3.7	Diurnal PFs of Turnout No. 2B for Wildomar Service Area	3-17
Figure 3.8	Diurnal PFs of Turnout No. 5 for Wildomar Service Area	3-17
Figure 3.9	Total System Diurnal for Wildomar Service Area	3-18
Figure 3.10	2015-2021 Railroad Canyon Average Historical Monthly Demands	3-21
Figure 3.11	Railroad Canyon Historical RW Consumption and Uses	3-23
Figure 3.12	Future RW System Demand - Railroad Canyon	3-25
Figure 3.13	Railroad Canyon Projected RW Demands Based on Five-Year Historical Maximum Demand for Each Month	3-28
Figure 3.14	RW PF Diurnal Curve of Cottonwood (Canyon Hills) Service Area	3-29
Figure 3.15	2017-2021 Horsethief RW Production and Demand	3-31
Figure 3.16	Future RW System Demand - Horsethief	3-35
Figure 3.17	Horsethief Projected RW Mid-Term Supplies and Demands (Year 2030)	3-38
Figure 3.18	Horsethief Canyon Projected RW Long-Term Supply and Demands (Year 2050)	3-38
Figure 3.19	Diurnal Curve of Hourly PF of Horsethief Service Area	3-39
Figure 3.20	2017-2021 Regional WRF RW Production and Discharge	3-41

Figure 3.21	Future RW System Demand - Regional	3-45
Figure 3.22	Projected Flows, Uses and Availability of Effluent at Regional WRF	3-49
Figure 4.1	RW System Overview	4-3
Figure 4.2	Wildomar RW System	4-5
Figure 4.3	Wildomar System Schematic	4-8
Figure 4.4	Railroad Canyon RW System	4-9
Figure 4.5	Railroad Canyon System Schematic	4-15
Figure 4.6	Horsethief RW System	4-17
Figure 4.7	Horsethief System Schematic	4-22
Figure 4.8	Regional RW System	4-23
Figure 4.9	Regional System Schematic	4-26
Figure 5.1	RW Model Screenshot	5-1
Figure 5.2	Wildomar System Diurnal Pattern	5-6
Figure 5.3	Cottonwood Diurnal Pattern (Used for Railroad Canyon and Horsethief Systems)	5-6
Figure 5.4	Horsethief Diurnal Pattern (AMI Data for Summer of 2021 Used)	5-7
Figure 7.1	Wildomar RW System Pressure and Velocity Results	7-3
Figure 7.2	Cottonwood System Storage Needs	7-7
Figure 7.3	Railroad Canyon WRF Storage Needs if CLGC Pond Nos. 4 and 5 Out of Service	7-8
Figure 7.4	Railroad Canyon WRF Storage Needs	7-9
Figure 7.5	Railroad Canyon RW System Pressure and Velocity Results	7-11
Figure 7.6	Horsethief Canyon RW System Storage Needs for 1518 Zone	7-15
Figure 7.7	Horsethief System Storage Needs for 1844 Zone	7-16
Figure 7.8	Horsethief System WRF Storage Needs	7-17
Figure 7.9	Horsethief Canyon RW System Pressure and Velocity Results	7-19
Figure 7.10	Pipeline Replacement by Planning Period	7-21
Figure 8.1	Wildomar Recommended Pipelines	8-9
Figure 8.2	Horsethief Canyon WRF Mid-Term Storage Needs	8-14
Figure 8.3	1518 Zone Mid-Term Storage Needs	8-15
Figure 8.4	1844 Zone Mid-Term Storage Needs	8-16
Figure 8.5	Horsethief Canyon WRF Long-Term Storage Needs	8-17
Figure 8.6	1518 Zone Long-Term Storage Needs	8-18

Figure 8.7	Horsethief Recommended Pipelines	8-21
Figure 8.8	Regional Supply Availability for IPR or NPR Projects	8-23
Figure 8.9	Proposed Groundwater Augmentation System	8-25
Figure 8.10	Regional Storage Needs for Potential Projects	8-29
Figure 8.11	Regional Recommended Pipelines	8-31
Figure 9.1	Railroad Canyon CIP Projects	9-7
Figure 9.2	Horsethief RW System CIP Projects	9-11
Figure 9.3	Proposed Back Basin IPR System	9-13
Figure 9.4	CIP Projects Based on Project Type	9-16
Figure 9.5	CIP Projects Based on User Cost	9-17
Figure 9.6	CIP Projects Based on Construction Time Period	9-18
Figure 9.7	CIP Expenditure by System by Phase	9-19

-This Page Intentionally Left Blank-

Abbreviations

ADD	average day demand
ADWF	average dry weather flow
AFY	acre-feet per year
AMI	Advanced Metering Infrastructure
APN	Assessor's Parcel Number
Carollo	Carollo Engineers, Inc.
CIP	capital improvement plan
CLGC	Canyon Lake Golf Course
DPR	direct potable reuse
DWR	Department of Water Resources
EMWD	Eastern Municipal Water District
ENR	<i>Engineering News-Record</i>
EPS	extended period simulation
EVMWD/ District	Elsinore Valley Municipal Water District
fps	feet per second
ft-msl	feet above mean sea level
GIS	geographic information system
gpm	gallons per minute
IPR	indirect potable reuse
M	million
MBR	membrane bioreactor
MDD	maximum day demand
MG	million gallons
mg/L	milligrams per liter
mgd	million gallons per day
MRPS	Mid-Range Pump Station
NPR	non-potable reuse
OPCC	opinion of probable construction cost
PF	peaking factor
PHD	peak hour demand
psi	pounds per square inch
RCWD	Rancho California Water District
RW	recycled water
RW R&R	2005 Rules and Regulations for Recycled Water Use
RWPS	Recycled Water Pump Station

RWQCB	Regional Water Quality Control Board
RWSMP	Recycled Water System Master Plan
SRRRA	Santa Rosa Regional Resources Authority
SSMP	Sewer System Master Plan
TVRWP	Temecula Valley Recycled Water Pipeline
TVRWRF	Temecula Valley Regional Water Reclamation Facility
UWMP	Urban Water Management Plan
WRF	water reclamation facility
WSMP	Water System Master Plan

EXECUTIVE SUMMARY

The 2023 Recycled Water System Master Plan (RWSMP) has been developed for the Elsinore Valley Municipal Water District (EVMWD or District) to explore opportunities to increase the use of recycled water (RW) in the cost-effective manner to offset potable water needs and increase supply reliability as the District's service area further develops.

The ultimate objective of this RWSMP is to provide EVMWD with a phased RW system capital improvement plan (CIP) that District staff can use as a planning roadmap for future RW investment decisions.

This document is divided into nine chapters. Chapter 1 serves as the introduction of the master plan. Chapter 2 discusses the study area and the land use. Chapter 3 focuses on the RW production and demand for historical and future use. Chapter 4 provides an overview of the existing system, while Chapter 5 delves into the RW system model. The planning and evaluation criteria used for this master plan is described in Chapter 6. Chapters 7 and 8 present the existing system analysis and the future system analysis, respectively. Based on these evaluations, Chapter 9 provides recommendations for the CIP, along with associated opinion of probable costs.

ES.1 Recycled Water Systems and Recommendations

EVMWD has four separate RW systems as shown on Figure ES.1:

- Wildomar.
- Railroad Canyon.
- Horsethief Canyon.
- Regional.

ES.1.1 Wildomar System

The Wildomar system receives water generated in EVMWD's Southern Section, treated at the Santa Rosa Regional Resources Authority's (SRRRA) Santa Rosa Water Reclamation Facility (WRF). This water is exchanged for RW from Eastern Municipal Water District (EMWD) conveyed through Temecula Valley Recycled Water Pipeline (TVRWP). EVMWD's monthly RW supply allocation from EMWD is determined at the beginning of each fiscal year based on EVMWD's actual average daily flow contribution to the Santa Rosa WRF during the previous fiscal year. If EVMWD does not use its allocation of RW, then it is forfeited to EMWD. The District has rights to receive up to 2.0 million gallons per day (mgd) of peak instantaneous supply. Currently, EVMWD is sending approximately 1.0 mgd to the Santa Rosa WRF, with plans to increase the flows to near 2.0 mgd in the next few years by diverting flow from additional lift stations.

Figure ES.2 shows the supply and demand balance for the Wildomar system. With existing flow diversions, there is sufficient flow available to serve existing customers. The majority of remaining supplies are expected to be used to meet demands for the Back Basin wetlands, which are expected to use all of the remaining flow available nine months a year (March to November), even with the expected increase in flows to 2 mgd. In the remaining three months, the Back Basin wetlands use some of the remaining available flow.

The existing RW demand of this system is 535 acre-feet per year (AFY), with demand of 410 AFY identified.

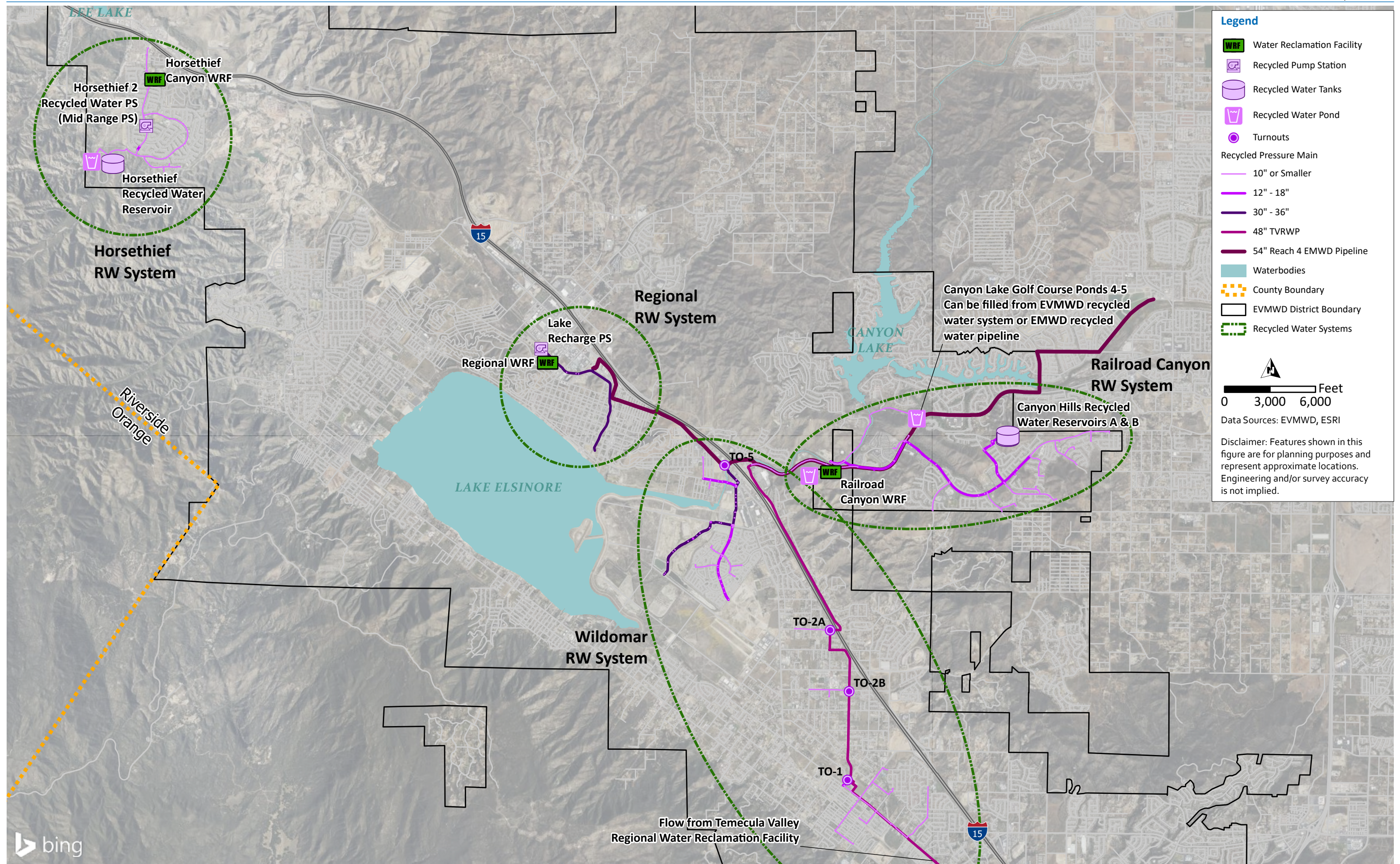

Legend

- Water Reclamation Facility
- Recycled Pump Station
- Recycled Water Tanks
- Recycled Water Pond
- Turnouts
- Recycled Pressure Main
 - 10" or Smaller
 - 12" - 18"
 - 30" - 36"
 - 48" TVRWP
 - 54" Reach 4 EMWD Pipeline
- Waterbodies
- County Boundary
- EVMWD District Boundary
- Recycled Water Systems

0 3,000 6,000 Feet

Data Sources: EVMWD, ESRI

Disclaimer: Features shown in this figure are for planning purposes and represent approximate locations. Engineering and/or survey accuracy is not implied.



Figure ES.1 RW System Overview

-This Page Intentionally Left Blank-

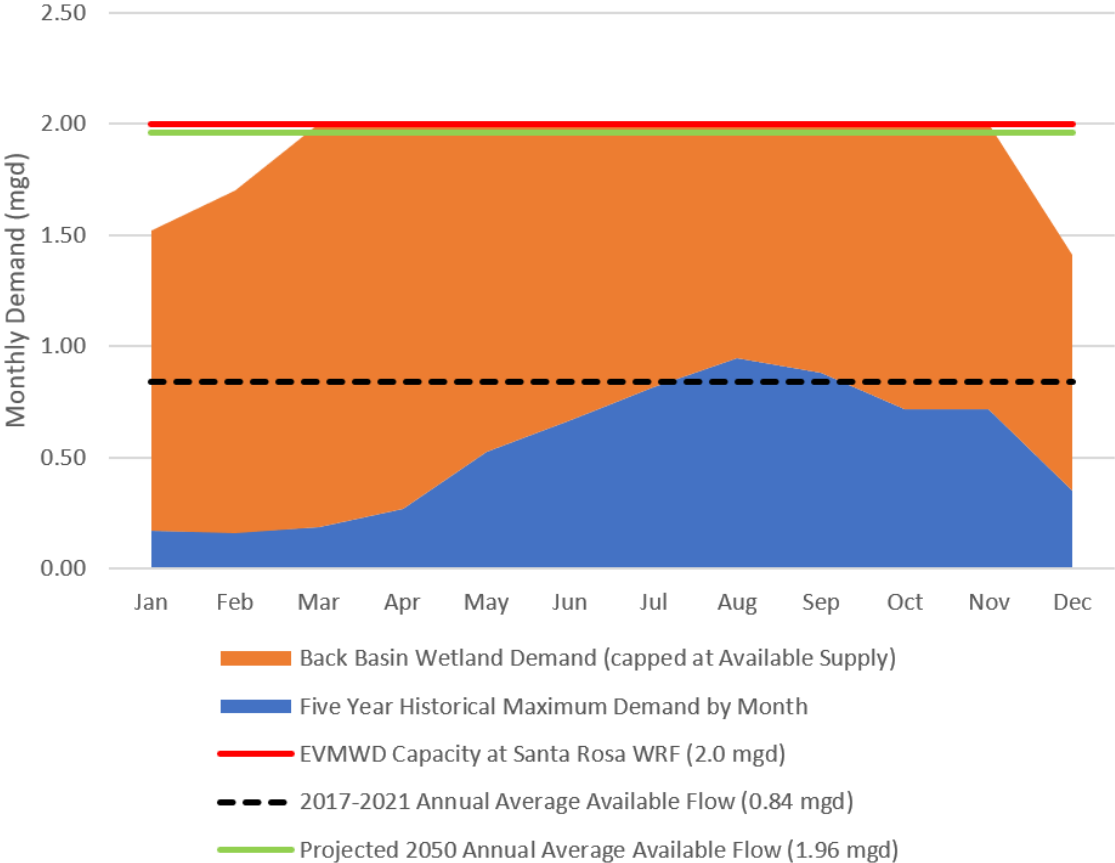

Figure ES.2 Supply and Demand Balance in Wildomar System

Given that it is expected that there will not be any additional supplies available nine months a year, no other projects are recommended. However, if additional RW supply becomes available, there is the potential of expanding the Wildomar system with other additional non-potable RW customers.

As shown on Figure ES.1, the TVRWP serves the Wildomar system through four RW turnouts (Turnout Nos. 1, 2A, 2B, and 5).

ES.1.2 Railroad Canyon System

The Railroad Canyon system receives supply from the Railroad Canyon WRF, a scalping plant with an operational capacity of 1.12 mgd (and temporary capacity of 0.6 mgd). Any excess raw wastewater at Railroad Canyon WRF not used for RW

production is bypassed to the Regional WRF. RW is stored at storage ponds at Railroad Canyon WRF and pumped into two different pressure zones and systems:

- The Canyon Lake Golf Course (CLGC) system is fed by two booster pumps, with water stored at two ponds near the golf course. The existing RW demand of this system is 270 AFY, with no additional future customers identified.
- The Cottonwood (or Canyon Hills) system is fed by three booster pumps, has two RW tanks, and serves a variety of irrigation customers in the Canyon Hills area. The existing RW demand of this system is 400 AFY, with only one future customer with a demand of 8 AFY identified.

During summer months, RW demands in the Railroad Canyon system exceed the historically available RW supplies of 1.04 mgd. To meet these demands, EVMWD has two supplemental sources of supply. EVMWD can purchase up to 320 acre-feet of RW annually (peak instantaneous flow of 200 gallons per minute [gpm]) from EMWD's Reach 4 pipeline, which directly serves the CLGC ponds. Additionally, EVMWD can supplement supplies by feeding potable water into the ponds at Railroad Canyon WRF.

Given the limited opportunities for additional RW demands in the Railroad Canyon system, no expansion is recommended. However, the existing booster pumps will need periodic replacement due to age and condition. If CLGC ponds are eliminated, then additional booster pumps will be necessary at Railroad Canyon WRF to feed the CLGC system.

ES.1.3 Horsethief System

The Horsethief system is supplied by the Horsethief Canyon WRF with an existing RW production capacity of 0.50 mgd, with the flow expected to increase to 0.80 mgd by 2050. There is the potential of significant increase in RW demands in the Horsethief system due to four potential developments: JBJ Ranch, Renaissance Ranch, Saddleback Estates, and SAM [formerly Horsethief Canyon]. The wastewater generated by these four developments will lead to sufficient RW supply for the four developments, and pipelines will be needed to serve them as shown on Figure ES.3.

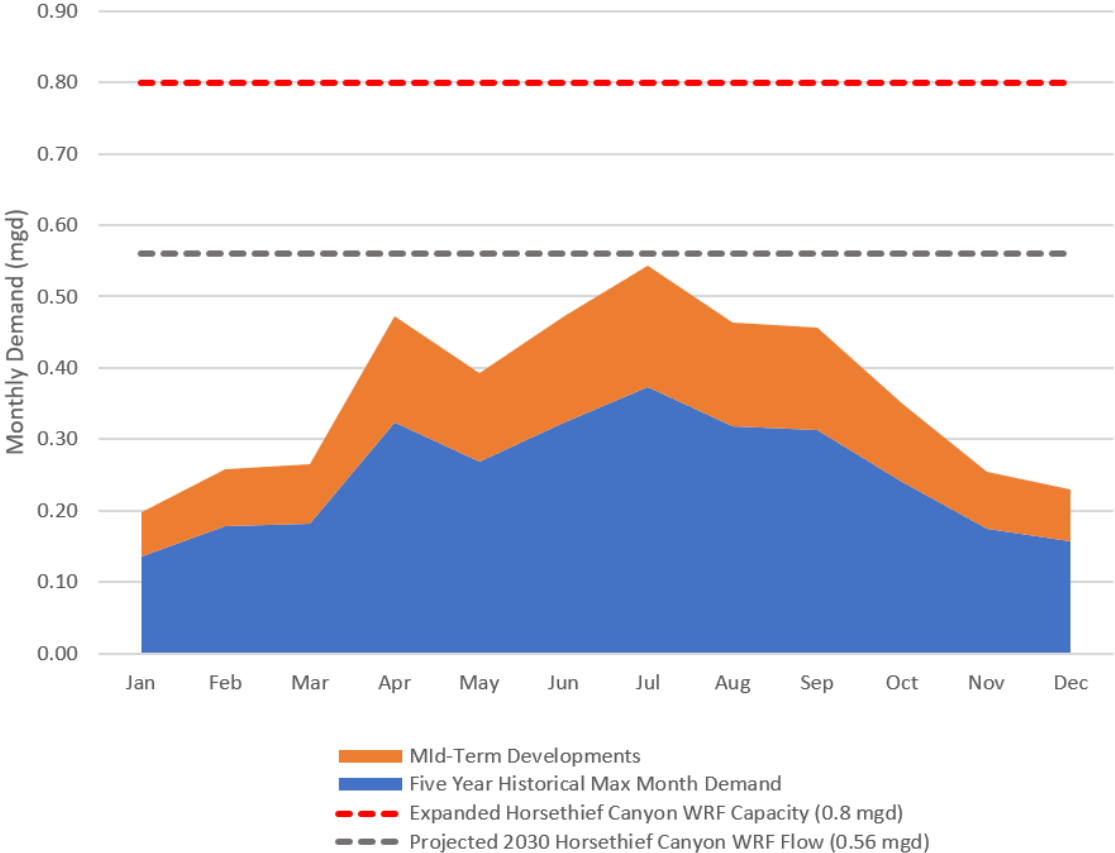

Figure ES.3 Supply and Demand Balance in Horsethief System for Year 2030

RW produced at the facility is stored in an on-site storage pond. From there all RW produced is pumped through an on-site pump station to the 1518 Pressure Zone and then to the 1844 Pressure Zone via the Mid-Range Pump Station (MRPS). There is a storage tank in the 1844 Pressure Zone. The existing RW demand of this system is 225 AFY, with a potential non-potable demand of 370 AFY by 2050.

If there is excess water, water from the storage tank is sent to a percolation pond for disposal. Supplemental RW supply from the potable water system is available to the Horsethief system, filling the wet well at the MRPS, if needed.

The pump station at the Horsethief Canyon WRF requires expansion as there is insufficient capacity to feed existing customers if one of the pumps is out of service. Additionally, the existing Horsethief system booster pumps will need periodic replacement due to age and condition.

Additionally, a second RW storage tank will be needed in the 1844 Pressure Zone to provide adequate RW service for these developments. The recommended projects are shown on Figure ES.4.

ES.1.4 Regional System

The Regional WRF currently produces an average of 6.1 mgd. The first 0.5 mgd of RW produced at Regional WRF is discharged into Temescal Wash for environmental mitigation. Less than 5 AFY is used for non-potable reuse (NPR) at EVMWD's office. The remaining flows are discharged to Lake Elsinore for lake level makeup, through the Lake Recharge Pump Station. Flows at Regional WRF above 8 mgd are expected to be available for other RW uses.

To maximize the potential of the expected flows, it is recommended that EVMWD implement an indirect potable reuse (IPR) project once the flows at Regional WRF exceed 8 mgd. This project involves providing advanced treatment to the Regional WRF tertiary effluent and then either recharge the product water into Back Basin area for storage and recovery to be used as a potable water supply or take the water to blend in with Canyon Lake water and then treat at the Canyon Lake Water Treatment Plant for potable use. EVMWD may also consider a direct potable reuse (DPR) option in place of IPR, subject to the developing regulations. The final decision to select any one of the three options shall be made at a later date.

It is expected there will be sufficient flows for the IPR project in year 2030 as shown on Figure ES.5. The IPR project is shown on Figure ES.4.

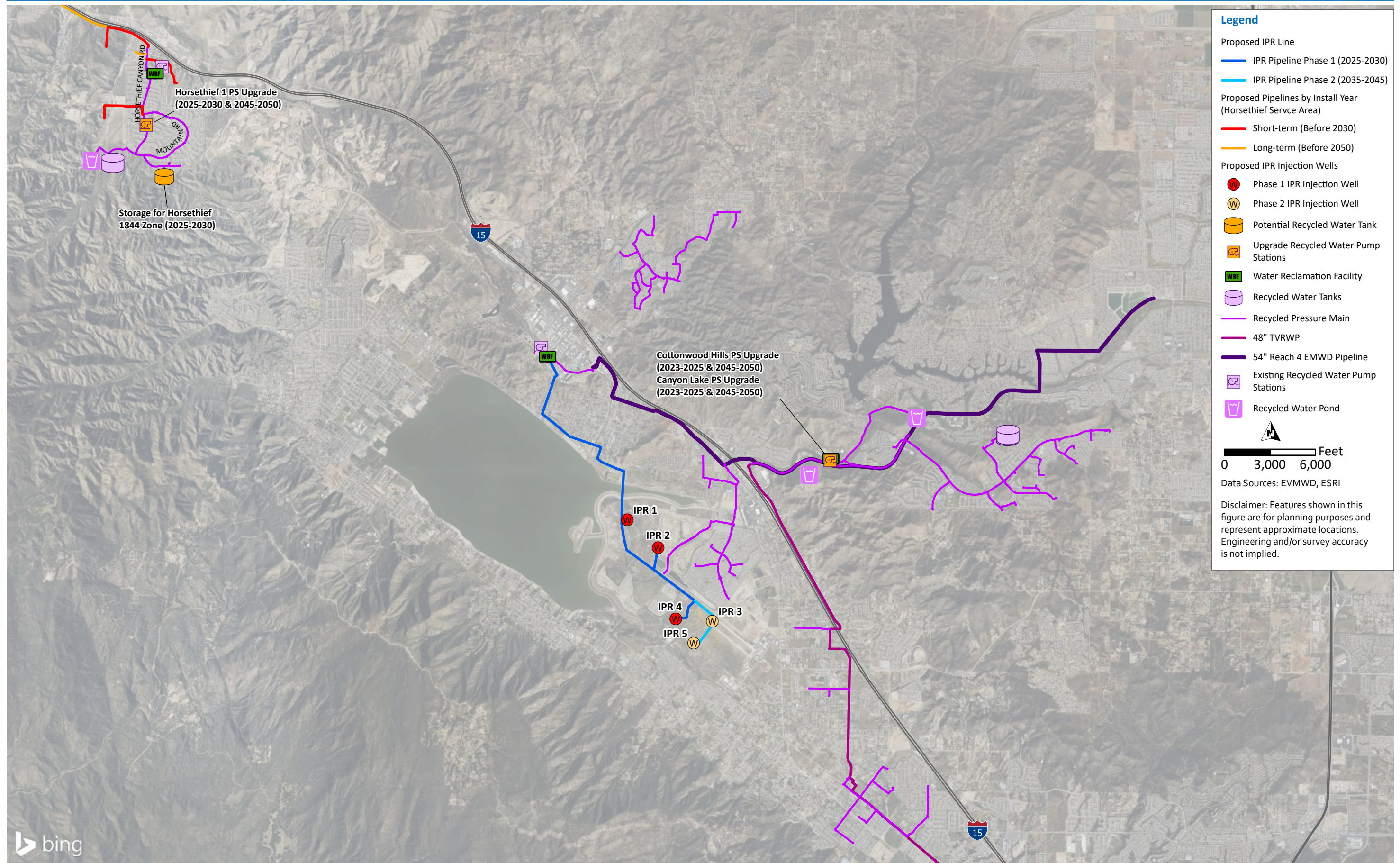

Figure ES.4 CIP Overview

-This Page Intentionally Left Blank-

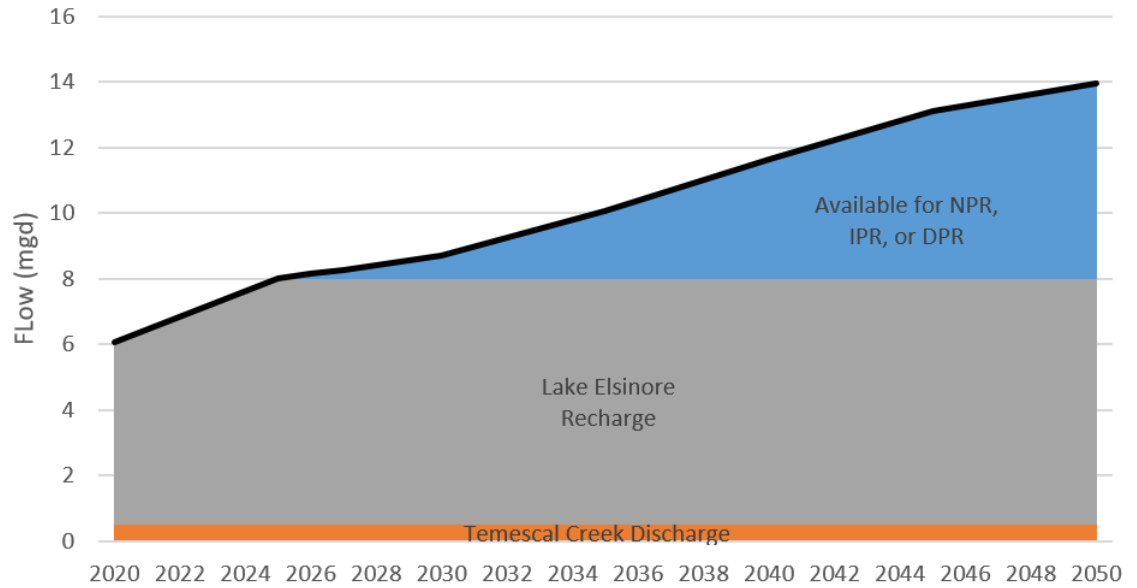

Figure ES.5 Projected Supply and Demand Balance for Regional WRF

However, if the IPR project is deemed infeasible, this Plan also evaluates the potential of using the excess RW flows for irrigation through a non-potable RW distribution system.

ES.2 Capital Improvement Program

The recommended projects for the RW system by phase and system are estimated to cost approximately \$175 million (M) (in 2023 dollars) as summarized in Table ES.1 and shown on Figure ES.6. The breakdown of cost between existing and future system ratepayers are summarized in Table ES.2.

Table ES.1 RW System CIP Cost Summary by System and Phase

System	2023-2025	2025-2030	2030-2035	2035-2040	2040-2045	2045-2050	Total
Horsethief Canyon	\$-	\$8.9 M	\$-	\$-	\$2.2 M	\$0.4 M	\$11.5 M
Railroad Canyon	\$0.4 M	\$-	\$-	\$-	\$0.45 M	\$-	\$0.9 M
Regional	\$-	\$-	\$104.0 M	\$58.0 M	\$-	\$-	\$162.0 M
CIP Total	\$0.4 M	\$8.9 M	\$104.0 M	\$58.0 M	\$2.6 M	\$0.4 M	\$174.4 M

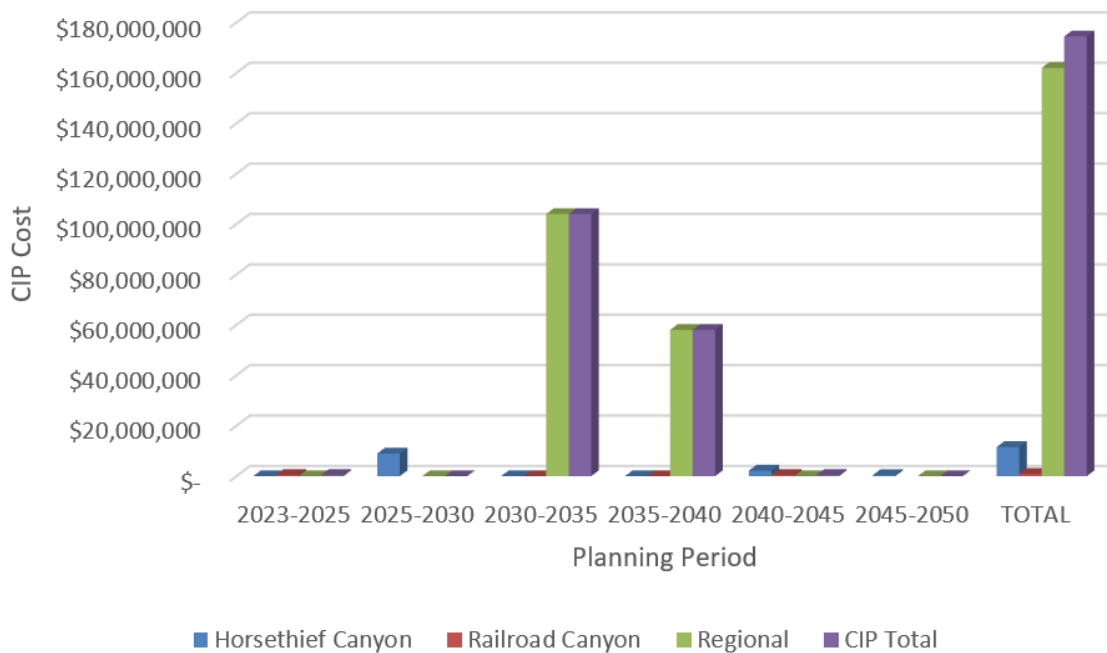

Figure ES.6 CIP by System and Phase

Table ES.2 RW System CIP Cost Summary by Existing and Future Users⁽¹⁾

Improvement Type	Existing User Cost (\$ M)	Future User Cost (\$ M)	Total Cost (\$ M)	Percentage
Pipelines	\$-	\$8.0	\$8.0	4.6%
Potable Reuse	\$-	\$162.0	\$162.0	92.9%
Pump Station Upgrade	\$2.5	\$-	\$2.5	1.4%
Pump Replacement	\$0.8	\$0.8	\$1.6	0.9%
Storage Reservoir	\$-	\$0.3	\$0.3	0.2%
RW Improvements Total	\$3.3	\$171.0	\$174.0	100%

Notes:

(1) Costs shown are in 2023 dollars.

As shown in Table ES.1 and Figure ES.7, the IPR project accounts for 93 percent of the total CIP cost, while pipeline projects account for 5 percent and pump station upgrades, pump replacement, and storage tank projects account for the remaining 2 percent. It is expected that future users will cover 98 percent of the total CIP cost, with existing users responsible for the remaining 2 percent. Since the majority of the costs are associated with the IPR project, most of the costs will occur during implementation of the IPR project, with Phases 1 and 2 expected to occur from 2030-2035 and 2035-2040, respectively.

As shown in Table ES.2, only \$3.3 M of the total \$174 M CIP is associated with the rehabilitation and replacement of existing RW system infrastructure due to the relatively new system components compared to EVMWD’s water and wastewater infrastructure. As a result, less than 2 percent of the CIP cost is allocated to existing customers, while the remaining 98 percent is categorized as future system cost to be paid by future customers through development connection fees.

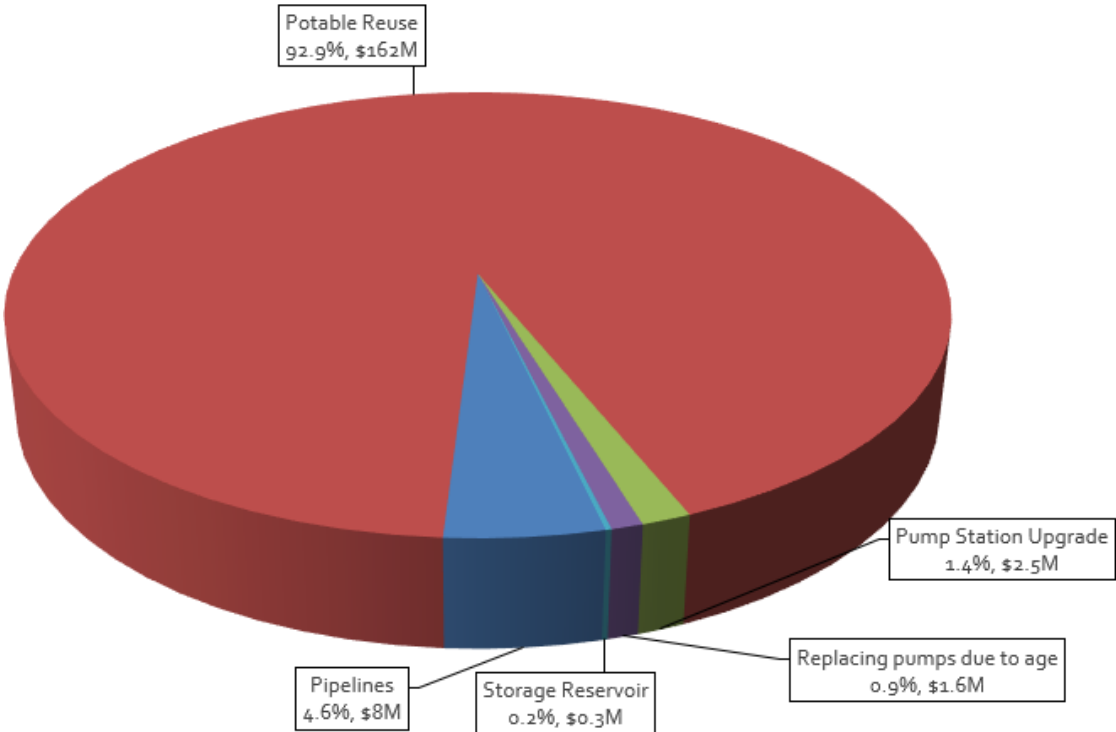

Figure ES.7 CIP by Facility Type

-This Page Intentionally Left Blank-

Chapter 1

INTRODUCTION

This chapter provides an introduction to the Recycled Water System Master Plan (RWSMP) for the Elsinore Valley Municipal Water District (EVMWD or District), beginning with the project background. The project objectives are presented, followed by a concise overview of the scope of work, team involvement and acknowledgements. This chapter concludes with a description of the organization of the RWSMP report.

1.1 Project Background

The last RWSMP for EVMWD was completed by MWH in 2016. Since then, there has been significant development within EVMWD's service area, resulting in population growth and increased demands for both potable and non-potable water supplies. However, water conservation and efficiency have also improved, and potable reuse regulations have advanced rapidly over the past decade. These factors have created a need to update the 2016 RWSMP.

The aim of the current RWSMP is to develop a document that will serve as a guideline for planning EVMWD's recycled water (RW) system. This RWSMP has a planning horizon up to the year 2050 and assesses EVMWD's RW system under both existing and future conditions.

This RWSMP covers EVMWD's four RW service areas:

- Wildomar service area.
- Railroad Canyon service area.
- Horsethief Canyon service area.
- Regional service area.

The proposed developments within EVMWD's service area represent a significant opportunity for growth. Accordingly, the planning and sizing of new facilities to serve the new developments are a key focus of this RWSMP. The objective is to ensure that EVMWD's RW system can meet the increased demands for non-potable water while optimizing efficiency and sustainability.

Concurrently with the development of this RWSMP, Carollo Engineers, Inc. (Carollo) is updating the Water System Master Plan (WSMP) and the Sewer System Master Plan (SSMP). All three plans are based on the same set of growth and flow assumptions. The WSMP evaluates the potable water distribution system under

both existing and future demand conditions and analyzes alternatives for the conveyance of potable water to existing and future customers. It identifies system deficiencies and recommends improvements, which are prioritized in a capital improvement plan (CIP) for the water distribution system, using the same cost assumptions as the RWSMP. The SSMP evaluates the District's sewer collection system using existing and projected future wastewater flows, identifies system deficiencies, and recommends improvements. A CIP for the sewer collection system prioritizes these improvements. The SSMP also includes RW flow availability projections for each of the four critical service areas listed above, which are essential for evaluating RW expansion opportunities in this RWSMP.

1.2 Project Objectives

The District's mission is to "manage its natural resources to provide reliable, cost-efficient, high-quality water and wastewater services for the communities they serve, while promoting conservation, environmental responsibility, education, community interaction, ethical behavior, and recognizing employees as highly valuable assets."

This RWSMP is developed to assist the District in achieving these objectives by meeting the following goals:

- Developing an infrastructure plan that balances reliability and cost.
- Creating an accurate and usable calibrated hydraulic model.
- Evaluating RW system performance.
- Identifying needed capital improvement projects.
- Transferring knowledge to EVMWD's staff.

The ultimate objective of this RWSMP is to provide EVMWD with a phased RW system CIP that District staff can use as a planning road map for future RW investment decisions.

1.3 Scope of Work

The Scope of Work of this RWSMP consists of the following tasks:

- Update EVMWD's 24-hour RW hydraulic model.
- Project RW demands in the service area up to year 2050.
- Perform a RW supply and demand analysis.
- Conduct storage, booster station, and system reliability analysis.
- Analyze the RW distribution system under existing conditions.
- Analyze the RW distribution system under future conditions.
- Identify RW system improvements.
- Prepare a CIP for the RW system.
- Consult with EVMWD staff on the needs of the system.

As part of this RWSMP, an updated 24-hour extended period simulation computer model of the RW system has been developed. The RW model includes all pipelines within EVMWD's system and incorporates future system elements that will be required to meet the service conditions through 2050. The purpose of the model is to analyze the system under existing and future demand conditions, identify constraints and deficiencies in existing infrastructure, recommend mitigation measures, and develop conceptual infrastructure to serve future demands.

A comprehensive CIP has been prepared that includes all necessary system improvements required to meet the RW system needs through the year 2050. The CIP identifies system deficiencies and improvements needed to address these deficiencies, maximize RW opportunities, and proposes phasing and cost estimates for the recommended improvements. The CIP will provide EVMWD with a roadmap for future RW system planning.

During the preparation of this RWSMP, EVMWD staff provided numerous reports, maps, studies, and other sources of information. Additionally, pertinent materials were obtained from sources such as United States Geological Survey, Esri, and others. These materials included water system maps, planning and development information, general plan land use, historical records, billing data, and detailed facility information. Meetings were also held throughout the project with EVMWD's engineering and planning, management, and operational staff to utilize their knowledge and information during the hydraulic model development and calibration stages. A complete list of reference documents is provided in Appendix A.

1.4 Authorization

This RWSMP has been developed in accordance with the agreement between the EVMWD and Carollo dated December 16, 2021.

1.5 Acknowledgements

Carollo wishes to acknowledge and thank all of EVMWD's staff for their assistance and support in completing this project. Carollo would especially like to thank the following individuals:

- Parag Kalaria, Director of Water Resources and Project Manager.
- Jason Dafforn, Engineering and Water Resources Director (former).
- Sudhir Mohleji, Principal Engineer.
- Mike Ali, Water Quality Administrator.
- Jesus Gastelum, Senior Water Resources Planner/Engineer.
- Shane Sibbett, Civil Engineer.
- Matthew Bates, Engineering Manager (former).
- Mayra Cabrera, Principal Engineer.
- David Ochoa, Water Protection Supervisor.
- Lenai Hunter, Regulatory Compliance Specialist.

1.6 Project Staff

The following Carollo staff was principally involved in the preparation of this RWSMP:

- Principal-in-Charge: Eric Mills, P.E.
- Project Manager: Inge Wiersema, P.E.
- Project Engineer: Matthew Huang, P.E.
- Technical Reviewer: Anthony Herda, P.E.
- RW Demands: Rachel Duncan, P.E.
- Hydraulic Modeling and Analysis: Vidula Bhadkamkar, P.E.
- GIS Specialists: Jackie Silber, GISP and Kevin Christensen.

1.7 Master Plan Outline

This document is divided into nine chapters. Chapter 1 serves as the introduction of the master plan. Chapter 2 discusses the study area and the land use. Chapter 3 focuses on the RW production and demand for historical and future use. Chapter 4 provides an overview of the existing system, while Chapter 5 delves into the RW system model. The planning and evaluation criteria used for this master plan is described in Chapter 6. Chapter 7 and Chapter 8 present the existing system analysis and the future system analysis, respectively. Based on these evaluations, Chapter 9 provides recommendations for the CIP, along with associated costs. Supporting documents are included in appendices, while acronyms used in this RWSMP are listed at the end of the Table of Contents.

Chapter 2

STUDY AREA AND LAND USE

This chapter describes Elsinore Valley Municipal Water District's (EVMWD's) service area and the spatial boundaries of this study as well as land use within EVMWD's service area.

2.1 Study Area

EVMWD is a public non-profit agency that was created on December 23, 1950, that provides public water service, water supply development and planning, wastewater treatment and disposal, and recycled water (RW) service.

The study area for this master plan is EVMWD's service area, which is located in southwestern Riverside County and eastern Orange County. EVMWD is located approximately 18 miles northwest of the city of Temecula, 25 miles west of the city of Hemet, and 22 miles southeast of the city of Corona. EVMWD provides water services to the cities of Lake Elsinore and Canyon Lake, and portions of the city of Wildomar, city of Murrieta, and unincorporated Riverside County and Orange County land, as shown on Figure 2.1. The unincorporated communities within EVMWD's service area include The Farm, Lakeland Village, Cleveland Ridge, Rancho Capistrano, El Cariso Village, Horsethief Canyon, Sedco Canyon, and Temescal Canyon.

The size of the EVMWD service area is approximately 98.5 square miles. The EVMWD service area has a high elevation of over 3,000 feet above mean sea level (ft msl) and a low elevation of approximately 1,250 ft msl. EVMWD is bordered by the Cleveland National Forest to the southwest, which is part of the Santa Ana Mountains. Because of these mountain ranges surrounding EVMWD, as well as flat areas surrounding the lake, EVMWD has several pump stations to pump RW up the steep slopes, as needed.

The most prominent geographic feature of the EVMWD service area is Lake Elsinore, an approximately 3,000-acre natural freshwater lake that is fed by the San Jacinto River during wet weather and can overflow to the Santa Ana River and eventually to the Pacific Ocean. Lake Elsinore sits in the center of the EVMWD service area. RW from the EVMWD Regional Water Reclamation Facility (WRF) is discharged into Lake Elsinore to sustain the levels.

EVMWD’s service area also includes Canyon Lake, a 525-acre reservoir created in 1928 by the construction of the Railroad Canyon Dam. The reservoir is supplied by the San Jacinto River and Salt Creek and acts as a drinking water reservoir for EVMWD.

EVMWD’s service area is divided into two separate divisions: the Elsinore Division and Temescal Division. The Temescal Division service area is located northwest of the Elsinore Division service area.

EVMWD serves potable water to a population of approximately 165,000 and serves non-potable RW to a smaller subset of four separate areas within its larger service area. All RW systems are within the Elsinore Division service area.

2.1.1 Service Area Population

Current population served and future population projections for the service area developed in support of EVMWD’s 2020 Urban Water Management Plan (UWMP, WSC, 2021) were adopted for the Water System Master Plan (WSMP).

For the 2020 UWMP, the Department of Water Resources Population Tool, the Southern California Association of Governments 2020–2045 Regional Transportation Plan, and staff input were considered for the current and projected population estimates. In recent years, the number of potable water service connections within EVMWD’s service area has grown at a rate of 1.5 percent per year, and this growth is expected to continue through 2050. Table 2.1 shows the current and projected population for the EVMWD service area. Note that RW customers make up a small subset of total customers.

Table 2.1 EVMWD Service Area Population Projection⁽¹⁾

Year	EVMWD Population Served
2020	163,984
2025	176,657
2030	190,310
2035	205,018
2040	220,863
2045	237,932
2050	256,320

Notes:

(1) Source: 2020-2045 population estimates from EVMWD’s 2020 UWMP (WSC, 2021), and the 2050 estimate was calculated using a continued growth rate of 1.5 percent per year.

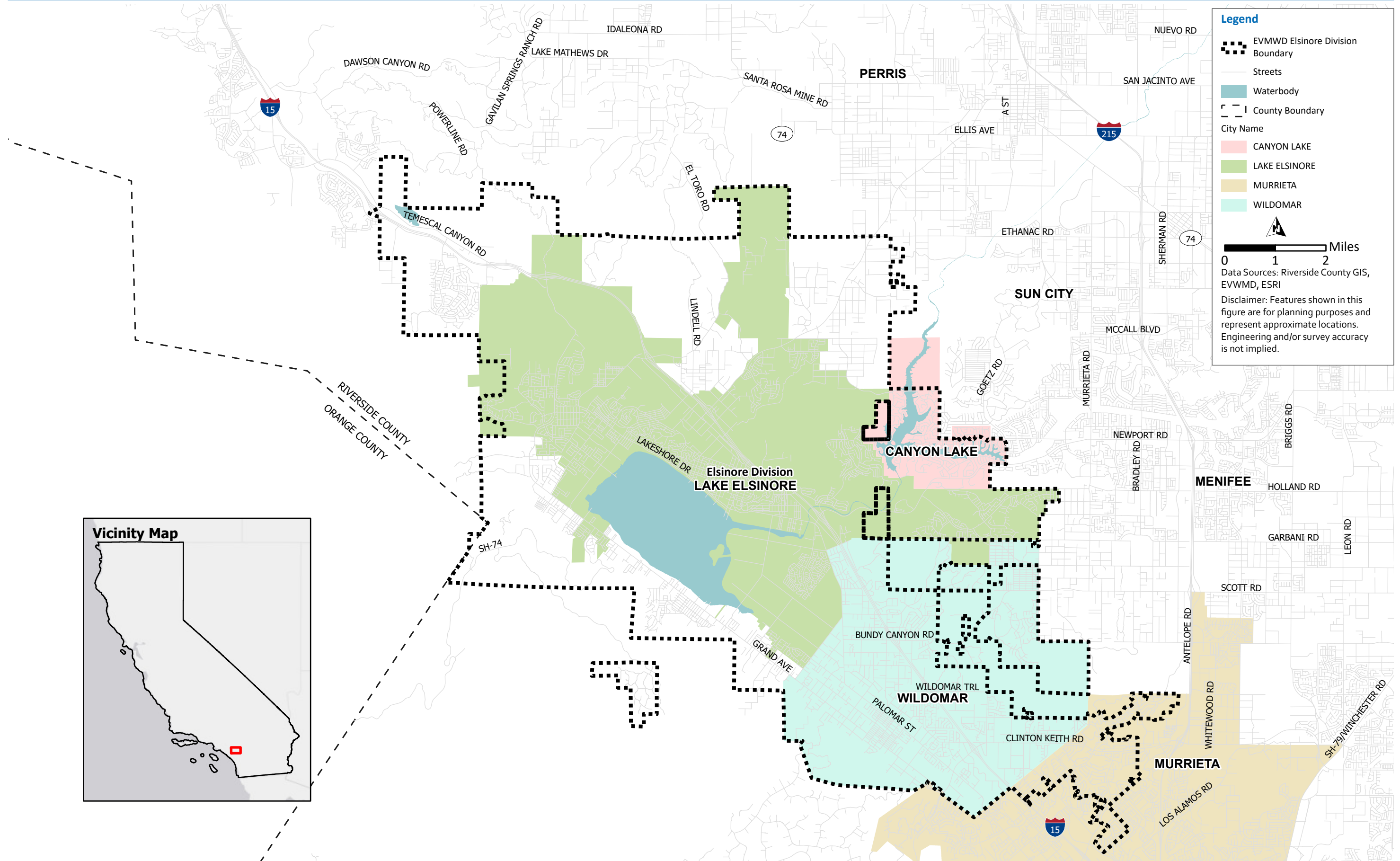

Figure 2.1 EVMWD Service Area

-This Page Intentionally Left Blank-

2.1.2 Recycled Water System Overview

EVMWD presently owns and operates three WRFs: Horsethief Canyon WRF in the northern section of the service area, with a current capacity of 0.5 million gallons per day (mgd), which will be expanded to 0.8 mgd in the near future; Railroad Canyon WRF, with a capacity of 1.12 mgd; and the Regional WRF, with a related capacity of 7.5 mgd. As of 2023, a project is in progress to increase the Regional WRF's capacity by 4-mgd average daily flow using a membrane bioreactor (MBR) process. Some flows from the southern section of the system, specifically the Cal Oaks area, are conveyed to the Santa Rosa Regional Resources Authority (SRRRA) for treatment at its Santa Rosa WRF.

EVMWD has been providing RW to its customers since the 1990s, and their customer base has grown to include public and private irrigation customers such as parks, schools, and golf courses. EVMWD's RW service area is comprised of four hydraulically separated service areas: Horsethief Canyon, Railroad Canyon, Regional, and Wildomar service areas. Each respective service area is served by the following sources:

- Wildomar service area is served RW by the Eastern Municipal Water District's (EMWD) 48-inch Temecula Valley Recycled Water Pipeline (TVRWP). The Santa Rosa WRF is operated by the SRRRA, a Joint Powers Authority formed by EVMWD, Rancho California Water District (RCWD), and EMWD, and it treats portions of the wastewater flow generated in the southern section of the EVMWD's service area. EVMWD's water from Santa Rosa WRF is traded with water from EMWD's Temecula Valley Regional Water Reclamation Facility (TVRWRF), which is delivered through the TVRWP to EVMWD's Wildomar service area. The full text of this agreement can be found in Appendix B and is discussed further in Chapter 3. RW is served to customers within Wildomar, and any excess RW is ultimately disposed of by EMWD into the Temescal Wash at Wasson Sill.
- Railroad Canyon service area is served by RW produced at Railroad Canyon WRF. Potable water can be supplemented at the Railroad Canyon WRF when the demand exceeds production of RW. RW is served to customers within Cottonwood and Canyon Lake, including the Canyon Lake Golf Course (CLGC). EVMWD also has an agreement with EMWD to serve CLGC during summer months.
- Horsethief Canyon service area is served by RW produced at the Horsethief Canyon WRF. The RW from the WRF is pumped to a reservoir and then served to customers in the northwestern corner of EVMWD's service area in unincorporated Riverside County. During low-demand periods, excess RW from the reservoir is discharged into a percolation pond.

- Most of the Regional WRF treated Title 22 effluent is discharged to Lake Elsinore to sustain its level, and about 0.5 mgd is discharged into the Temescal Creek to maintain the riparian habitat; only a small portion of the Regional WRF RW is used for landscape irrigation at the Regional WRF facility and adjoining office buildings.

2.2 Land Use

The general plans of the cities of Lake Elsinore, Canyon Lake, Wildomar, and Murrieta, as well as Riverside and Orange County, guide development and establish long-range development policies within their jurisdictions that overlap with EVMWD’s service area. Land use information is an integral component in determining the amount of future potable and RW use and wastewater generation within EVMWD's boundaries. The type of land use in an area will affect the volume and timing of water use as well as the volume, timing, and water quality characteristics of the wastewater generation. Adequately estimating the water use and generation of wastewater from various land use types is important in sizing and maintaining effective water and sewer system facilities.

Figure 2.2 shows the land use categories within EVMWD's service area. Each land use category is defined, and the approximate percentage of EVMWD's service area comprised of that land use type is shown, in Table 2.2. Low-density residential is the largest land use category in EVMWD's service area, with significant amounts of medium-density residential, industrial, and open-space land uses as well. A large portion of the service area is categorized as vacant, under construction, or undevelopable, indicating a significant potential for growth.

Table 2.2 Land Use Designations

Land Use Category ⁽¹⁾	Percentage of EVMWD Service Area	Definition
Low-Density Residential	31%	This designation provides for single-family detached homes, secondary residential units, hobby farming and keeping of animals, public and quasi-public uses, and similar and compatible uses. Clustered single-family development may also be encouraged within this designation to minimize grading requirements and impacts on environmentally sensitive areas. Residential densities shall be between 1 and 6 dwelling units per net acre.

Land Use Category ⁽¹⁾	Percentage of EVMWD Service Area	Definition
Medium-Density Residential	17%	This designation provides for typical single family detached and attached homes, duplexes, triplexes, fourplexes, multi-family residential units, group quarters, public and quasi-public uses, and similar and compatible uses. Residential densities shall be between 7 and 18 dwelling units per net acre.
High-Density Residential	1%	This designation provides for single-family attached homes, multi-family residential units, group quarters, public and quasi-public uses, and similar and compatible uses. Residential densities shall be between 19 and 24 units per net acre.
Commercial	2%	This designation provides for retail, services, restaurants, professional and administrative offices, hotels and motels, mixed-use projects, public and quasi-public uses, and similar and compatible uses.
Mixed Use	3%	This designation provides for a mix of residential and non-residential uses within a single proposed development area.
Industrial	6%	This designation provides for office and administrative uses, light industrial, research and development, industrial parks, warehouses, manufacturing, office-based firms, including office support facilities, restaurants, medical clinics, public and quasi-public uses, and similar and compatible uses.
Open Space/ Recreational	9%	These designations provide for public and private areas of permanent open space and allow for passive and/or active private and public recreation. Open space and passive recreation areas include state and local parks, Bureau of Land Management lands, the Cleveland National Forest and/or private undeveloped lands. Active recreation includes uses such as golf courses and also allows for commercial recreation facilities such as water-oriented recreational uses.

Land Use Category ⁽¹⁾	Percentage of EVMWD Service Area	Definition
Public/ Institutional	3%	This designation indicates areas owned and maintained by public agencies such as school districts, water districts, utility companies, the County of Riverside, and the relevant city. Appropriate uses for this designation include schools, roads, drainage facilities, utility substations, sewage treatment plants, civic facilities and cemeteries, and similar and compatible uses.
Other ⁽²⁾	29%	Includes land that is vacant, under construction, undevelopable, unknown zoning, floodways, and a small amount of agriculture.

Notes:

- (1) Land use categories adapted from the City of Lake Elsinore’s General Plan (2011).
- (2) Not an officially designated land use category but used to capture land use types across jurisdictions that do not fit into another category.

2.2.1 Planned Developments

Since EVMWD's service area has a significant potential for additional growth, EVMWD tracks planned developments within each of the cities and unincorporated county areas within its boundaries in order to plan for their potential future water demand and wastewater collection needs. EVMWD is currently tracking over 300 planned developments. Over half of these developments are within the city of Lake Elsinore with a large number planned in the city of Wildomar and unincorporated Riverside County as well. The cities of Canyon Lake and Murrieta have relatively few planned developments within EVMWD’s service area.

The full list of planned developments tracked by EVMWD is included in Appendix C. The size, character, and location of the planned developments contributes to the spatial allocation of projected future water and RW demands and wastewater flows, as described in Chapters 3 and 8.

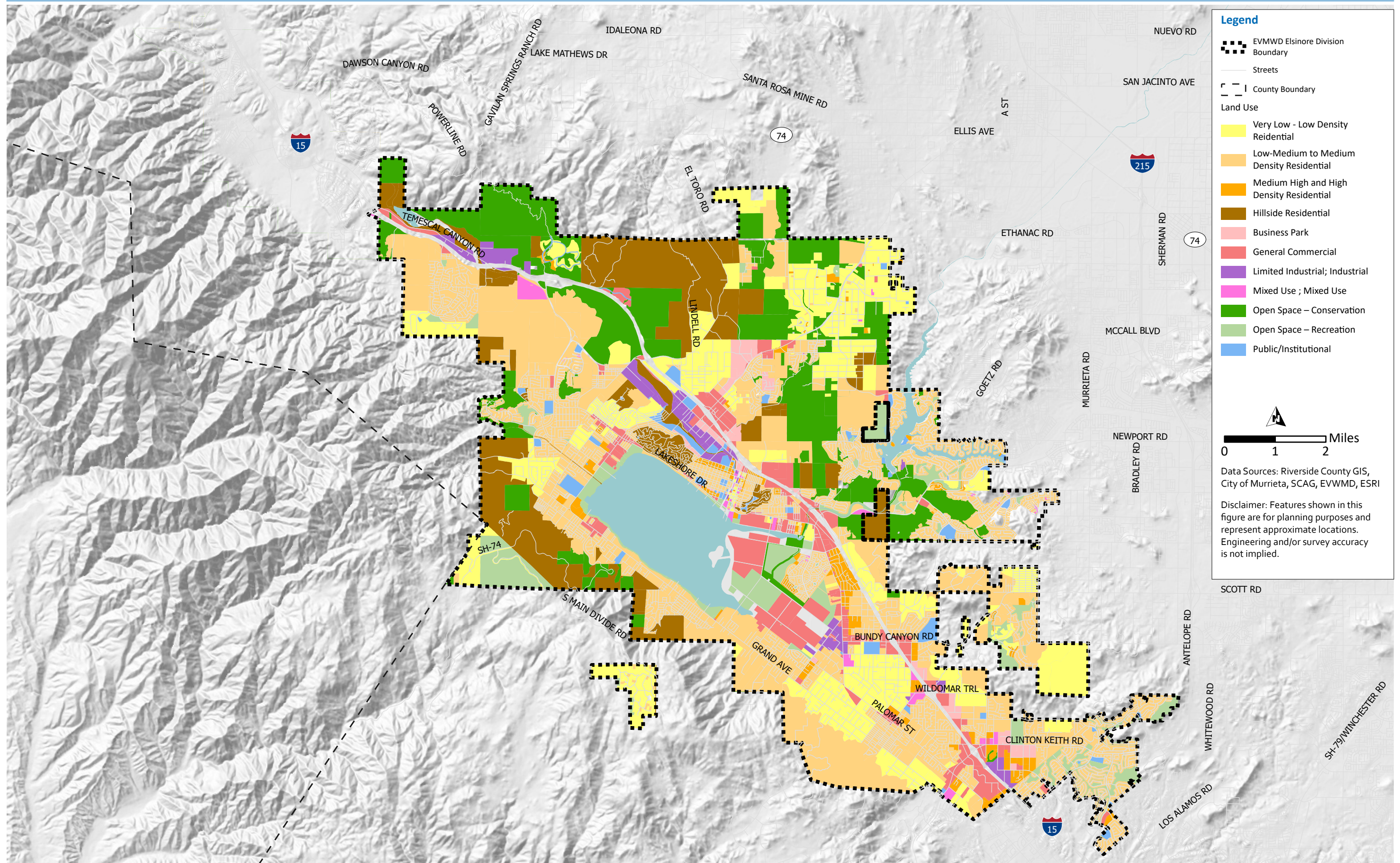

Legend

- EVMWD Elsinore Division Boundary
- Streets
- County Boundary
- Land Use**
- Very Low - Low Density Residential
- Low-Medium to Medium Density Residential
- Medium High and High Density Residential
- Hillside Residential
- Business Park
- General Commercial
- Limited Industrial; Industrial
- Mixed Use ; Mixed Use
- Open Space - Conservation
- Open Space - Recreation
- Public/Institutional

Miles
0 1 2

Data Sources: Riverside County GIS, City of Murrieta, SCAG, EVWMD, ESRI

Disclaimer: Features shown in this figure are for planning purposes and represent approximate locations. Engineering and/or survey accuracy is not implied.

Figure 2.2 Service Area Land Use

-This Page Intentionally Left Blank-

Chapter 3

RECYCLED WATER PRODUCTION AND DEMAND

This chapter provides information on the potential production of recycled water (RW) based on historical and projected wastewater flows. It also includes data on historical and existing RW demands and commitments, as well as estimates for potential non-potable and RW demands.

As described in Chapter 2, Elsinore Valley Municipal Water District (EVMWD or District) operates a RW system that serves four separate areas, each of which uses RW from a distinct source. Three of these sources are owned and operated by EVMWD, Railroad Canyon Water Reclamation Facility (WRF), Horsethief Canyon WRF, and Regional WRF. One system, Wildomar area, receives water primarily from the Temecula Valley Regional Water Reclamation Facility (TVRWRF), which is owned and operated by Eastern Municipal Water District (EMWD). The Santa Rosa WRF has ability to provide RW if desired and available. This chapter is organized by the four RW systems.

3.1 Wildomar Recycled Water Supply and Demand

This section provides information on the RW supply source, existing RW customers, and estimated future RW demands for the Wildomar system. The seasonal and daily supply and demand analyses for this system are subsequently described.

3.2 Wildomar Recycled Water Supply Source

EVMWD does not own or operate any WRFs in the southeastern portion of its service area. Instead, wastewater flow generated from this area, known as the Southern Division Sewershed, is conveyed to four connection points in Rancho California Water District's (RCWD) system and then conveyed to the Santa Rosa WRF for treatment. The Santa Rosa WRF is operated by the Santa Rosa Regional Reclamation Authority (SRRRA), a joint powers agreement between EMWD, EVMWD, and RCWD. In exchange for the wastewater sent to the Santa Rosa WRF, EVMWD is allocated the same volume of RW from EMWD's TVRWRF as the volume of wastewater sent to Santa Rosa WRF. Thus, the contractual amount of flow available to EVMWD changes at the beginning of each fiscal year based on the actual average daily flow contributed to the Santa Rosa WRF during the previous fiscal year. The water is conveyed to EVMWD via EMWD's Temecula Valley Recycled

Water Pipeline (TVRWP). There are two operational constraints on the RW supply to the Wildomar system:

1. Total instantaneous flow rate in the TVRWP cannot exceed 2.0 million gallons per day (mgd) (1,389 gallons per minute [gpm]). A previous agreement between EMWD and EVMWD was for 1.54-mgd capacity from EMWD in the TVRWP. In 2016, an additional 0.46-mgd capacity was purchased, allowing for a total capacity of 2 mgd in the TVRWP.
2. The monthly average RW flow cannot exceed the actual annual average wastewater flow contribution to Santa Rosa WRF during the previous fiscal year.

Figure 3.1 shows the monthly average wastewater flows from EVMWD into Santa Rosa WRF from January 2017 through December 2021, as well as the annual average flows for each calendar year. As shown, monthly average flows to the Santa Rosa WRF have remained relatively constant, with higher-than-average flows during 2020, potentially due to water use changes during the COVID-19 pandemic. As shown in Table 3.1, flow to the Santa Rosa WRF in 2021 was 0.89 mgd, which was close to the average flow of 0.84 mgd over the past five years.

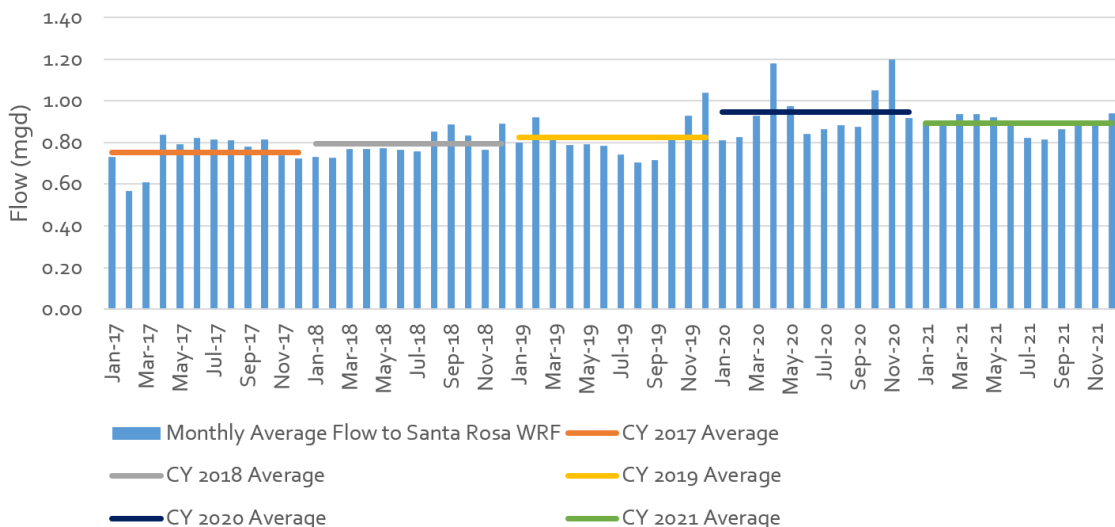

Figure 3.1 Wildomar Southern Division Sewershed Contribution to Santa Rosa WRF

Table 3.1 Wildomar Southern Division Sewershed Contribution to Santa Rosa WRF

Calendar Year	Annual Average Flow (mgd)
2017	0.75
2018	0.79
2019	0.82
2020	0.95
2021	0.89
2017-2021 Average	0.84

According to the EVMWD Sewer System Master Plan (SSMP), the total flow to the Santa Rosa WRF is expected to increase from the recent historical average of 0.84 mgd to 2 mgd by 2050 by diverting additional sewage flows that were previously routed to the Regional WRF (SSMP, Carollo Engineers, Inc., 2023). As of July 2022, approximately 0.125 mgd of additional flow has been diverted from Regional WRF to the Santa Rosa WRF at the Washington Lift Station (LS). In the near future, additional flows are expected to be diverted from the Greer and Robards LSs.

Since EVMWD has discharged an average 0.84 mgd (942 acre feet per year [AFY]) of wastewater to Santa Rosa WRF over the past five years, which has increased to approximately 1.1 mgd since the bypass of the Washington Avenue LS after its decommissioning in July 2022. Table 3.2 summarizes the Wildomar system RW supply sources.

Table 3.2 Wildomar RW Supply Sources

Facility	EVMWD Capacity in the TVRWP (mgd)	Existing Average Available Flow (mgd)
TVRWP	2.0	1.1

3.2.1 Recycled Water Customers

The Wildomar system currently serves 57 customer meters, which receive RW from four turnouts connected to the TVRWP. The average RW demand for the Wildomar system from 2017 through 2021 was approximately 0.34 mgd. The southernmost turnout (Turnout No. 1) is at the intersection of Gruwell Street and Orange Street and serves 13 customers. Turnout No. 2B is the next turnout north of Turnout No. 1 along the 48-inch diameter TVRWP, and it is located on Orange Street and Canyon Drive, serving three customers. Turnout No. 2A is located at Lemon Street and Almond Street, and it serves one customer. Turnout No. 5 is on the EMWD Reach 4 pipeline on Auto Center Drive, northwest of Railroad Canyon Road, and it serves 38 customers, including Railroad Canyon Elementary School, Lake Elsinore Diamond Stadium, and the Links at Summerly Golf Course. For a map of the existing RW customers, refer to Figure 4.2 in Chapter 4 of this Recycled Water System Master Plan (RWSMP).

3.2.2 Future Recycled Water Demand

Potential future non-potable RW demand in the Wildomar area was estimated by analyzing existing potable customer billing data as well as potable water demand projections associated with planned developments near the existing Wildomar RW system.

To estimate potential future non-potable RW demand in the Wildomar area, existing potable customer billing data and potable water demand projections associated with planned developments near the existing Wildomar RW system were analyzed. First, potential RW use percentages were applied to each customer based on customer billing types shown in Table 3.3. These RW use percentages were developed for each billing category based on Carollo Engineers, Inc.’s (Carollo) experience with other agencies and they indicate how much of the customer’s current potable water demand could potentially be converted to RW.

For example, the RW use percentage of 50 percent assigned to institutional customers indicates that half of an institutional customer’s demand could be converted to non-potable RW. Thus, if an institutional customer had 10 AFY of potable demand, approximately 5 AFY of that demand could potentially be met by non-potable RW. After these RW use percentages were applied to 2021 billing data, all customers with a potential RW demand greater than 5 AFY were considered potential candidates for non-potable RW system expansion.

Table 3.3 RW Use Percentages by Billing Category for Existing Potable Customers

Billing Category	% of Potable Water Customers That can be Converted to Non-Potable RW
Water - Agricultural	100%
Water - Commercial - Motorsports Park	95%
Water - Institutional	50%
Water - Commercial	30%
Water - Domestic	20%
Water - Domestic - Temescal Potable	20%
Water - Industrial - Temescal Potable	20%
Water - Wholesale	0%
Water - No Charge - EVMWD	0%
Water - No Charge - County Water	0%

Additional future RW demand may also derive from future planned developments. Potential RW demand for planned developments was estimated using a similar methodology as existing potable customers, with RW use percentages assigned to different types of planned developments as shown in Table 3.4. As with existing potable customers, these RW use percentages were applied to estimated potable water demand for each planned development (see the Water System Master Plan [WSMP] Chapter 3 for details on planned development estimated potable demands) to estimate the portion of that development’s demand that could be met with non-potable RW. Then, planned developments with potential RW demand greater

than 5 AFY were considered for non-potable RW system expansion. It should be noted that potential customers with smaller demands could be converted to RW but are typically too small to justify a system expansion. These smaller potential “pick-up” RW customers are not considered in this analysis but could be connected if there is a RW pipeline in close proximity or if there are other reasons to construct a RW pipeline to that location.

Table 3.4 RW Use Factors by Planned Development Type

Planned Development Type	RW Use Percentage
Open Space - Recreation	95%
Public/Institutional	50%
Business Park	30%
Commercial	30%
Industrial	20%
High Density Residential	20%
Mixed Use	20%
Open Space - Conservation	0%
Hillside Residential	0%
Very Low Density Residential	0%
Low Density Residential	0%
Low Medium Density Residential	0%
Medium Density Residential	0%
Medium High Density Residential	0%

Potential additional RW customers identified through the above analysis for all systems are shown on Figure 3.2. Potential additional RW customers for the Wildomar system are shown on Figure 3.3.

Potential RW customers were then grouped by system according to proximity to existing RW infrastructure. The potential RW users and demand associated with each RW system is described in each system section. The Wildomar system projects and customers are summarized in Table 3.5. As shown, the total potential additional RW demand from expansion projects is estimated to be 427 AFY. See Chapter 8 for details on required infrastructure for potential expansion to these customers.

Table 3.5 Wildomar Potential RW Customers

Customer Number	Customer/Planned Development Name	Potential Future Demand (AFY)	Potential Future Demand (mgd)	Existing Potable Customer or Planned Development	Plan Year
1	Lake Elsinore Commerce Center	66	0.059	Planned Development	2040
2	Hidden Springs Mixed Use	63	0.056	Planned Development	2035
3	Clinton Keith Mt. San Jacinto College Campus	56	0.050	Planned Development	2045
4	Rancon Medical and Education Center	23	0.021	Planned Development	2030
5	Canyon Hills Phase 7 Landscape	20	0.018	Planned Development	2023
6	Won Meditation/Retreat Center	17	0.015	Planned Development	2030
7	Inland Valley Medical Center	14	0.012	Planned Development	2030
8	Baxter Village	14	0.012	Planned Development	2024
9	Horizon Condos Tract 36672	12	0.011	Planned Development	2024
10	Hotel at Oak Creek Shopping Center	11	0.010	Planned Development	2030
11	Westpark	11	0.010	Planned Development	2030
12	Oak Springs Ranch	11	0.010	Existing Potable Customer	2030
13	94 Unit Apartments on Corydon Road and Sheets Lane	11	0.010	Planned Development	2045
14	Santa Rosa Apartments	10	0.009	Existing Potable Customer	
15	Greenspring Hotel	10	0.009	Planned Development	2045
16	Baxter Road and I-15 Mixed Use Project	9	0.008	Planned Development	2030

Customer Number	Customer/Planned Development Name	Potential Future Demand (AFY)	Potential Future Demand (mgd)	Existing Potable Customer or Planned Development	Plan Year
17	Artisan Alley	9	0.008	Planned Development	2040
18	Prielipp Apartments	8	0.007	Planned Development	2030
19	Orange Street Water and Sewer Improvements	8	0.007	Planned Development	2024
20	Lake Elsinore Motorsports Park	8	0.007	Existing Potable Customer	
21	Grove Park	7	0.006	Planned Development	2030
22	Oak Springs Ranch Phase 2	7	0.006	Planned Development	2030
23	Corydon Road and Grand Avenue Mixed Use - APN 370-171-015	6	0.005	Planned Development	2025
24	Villa Siena	5	0.004	Planned Development	2024
25	Econo Lodge Lake Elsinore Casino	5	0.004	Existing Potable Customer	
	Existing Potable Customer Subtotal	34	0.030		
	Planned Development Subtotal	387	0.345		
	Total	421	0.376		

Notes:
Abbreviations: APN - Assessor's Parcel No.

Along with potential planned developments, a large potential RW demand is the Back Basin wetlands. The Summerly development is responsible for purchasing water to maintain levels in the Back Basin wetlands for environmental purposes. Currently, there is a pipeline and pump station under construction. If RW is available and not used for irrigation from the Wildomar system, that water will be sent to the Back Basin wetlands if the water levels in the Back Basin wetlands are low. Based on information presented in Chapter 3, the Back Basin wetlands will have a demand ranging from 1.41 mgd in December to 3.61 mgd in July, depending on

evapotranspiration. To determine the monthly demands for the Back Basin wetlands, evapotranspiration was calculated from the data obtained from the California Irrigation Management Information System for the Temecula Valley Station 62, which was the closest station to the Back Basin location. This data was available from 1986 to 2022 and is shown in Table 3.6.

Table 3.6 Evapotranspiration Demand for Back Basin Wetlands⁽¹⁾

Month	Evapo- transpiration (inches/month)	Evapo- transpiration Demand (acre-feet/month)	Days in Month	Evapo- transpiration Demand (gpm)	Evapo- transpiration Demand (mgd)
January	2.80	145	31	1,059	1.52
February	2.83	146	28	1,183	1.70
March	3.96	205	31	1,496	2.15
April	4.88	253	30	1,907	2.75
May	5.43	281	31	2,054	2.96
June	6.11	316	30	2,385	3.43
July	6.64	344	31	2,509	3.61
August	6.42	332	31	2,427	3.49
September	5.16	267	30	2,015	2.90
October	4.07	211	31	1,539	2.22
November	3.14	163	30	1,227	1.77
December	2.59	134	31	979	1.41

Notes:

(1) Average demands from 1986 through 2022.

3.2.3 Seasonal Demand Variability

To assess the Wildomar system’s capacity to serve these potential future RW customers, the demands listed in Table 3.5 were converted to monthly demand estimates using monthly peaking factors (PFs) derived from historical RW demand data.

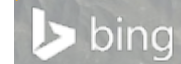
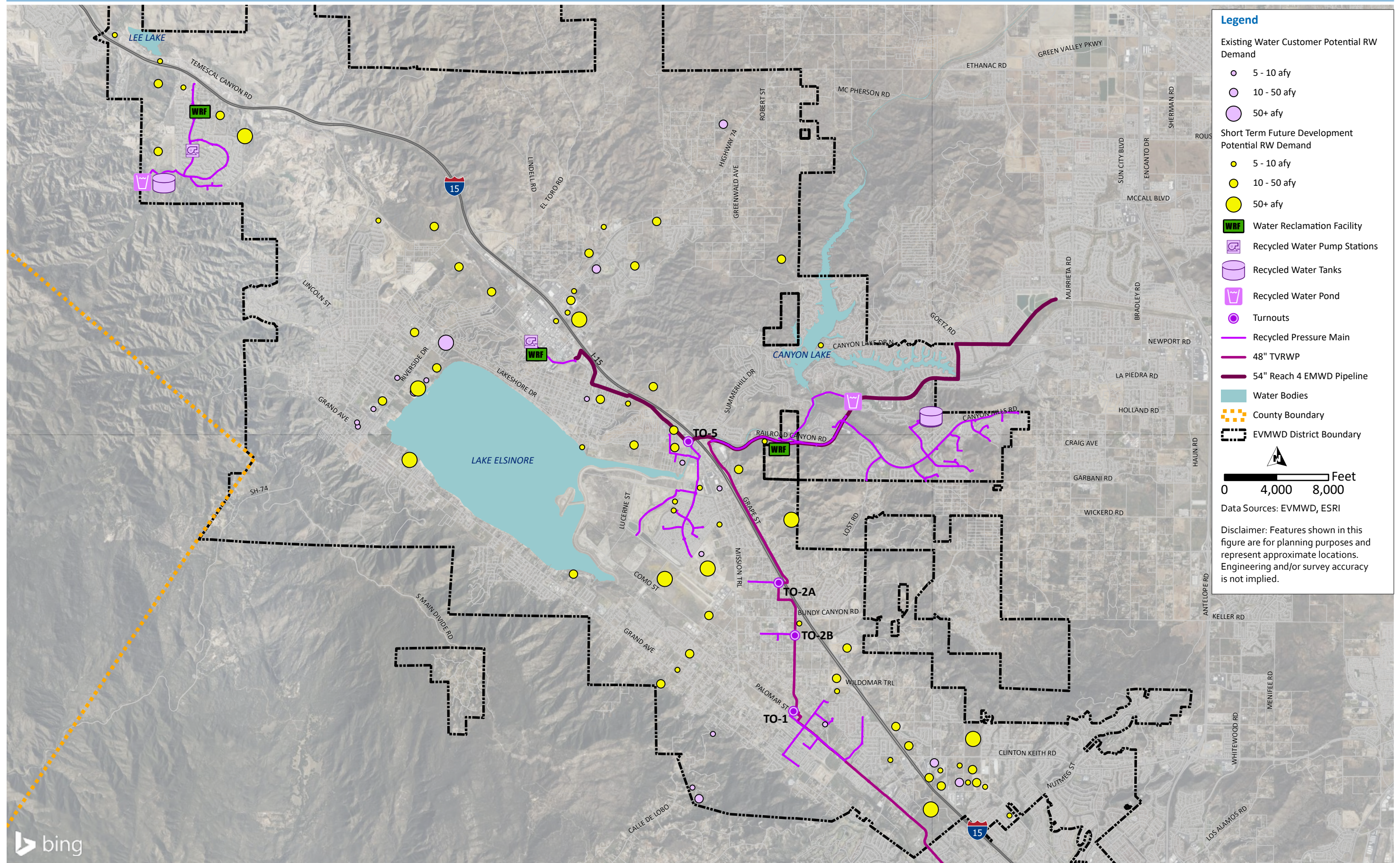
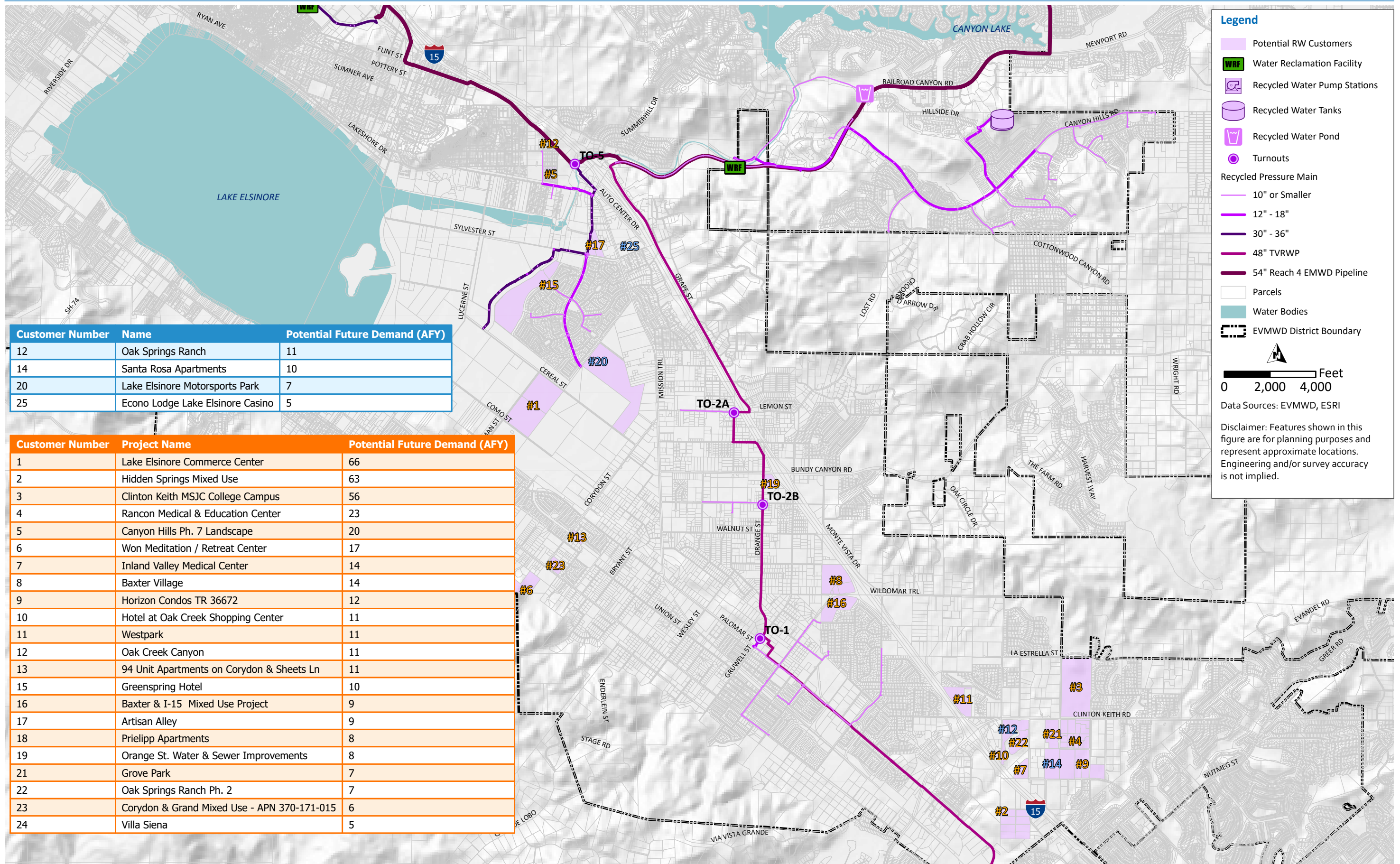

Figure 3.2 Future RW System Demand

-This Page Intentionally Left Blank-



Customer Number	Name	Potential Future Demand (AFY)
12	Oak Springs Ranch	11
14	Santa Rosa Apartments	10
20	Lake Elsinore Motorsports Park	7
25	Econo Lodge Lake Elsinore Casino	5

Customer Number	Project Name	Potential Future Demand (AFY)
1	Lake Elsinore Commerce Center	66
2	Hidden Springs Mixed Use	63
3	Clinton Keith MSJC College Campus	56
4	Rancon Medical & Education Center	23
5	Canyon Hills Ph. 7 Landscape	20
6	Won Meditation / Retreat Center	17
7	Inland Valley Medical Center	14
8	Baxter Village	14
9	Horizon Condos TR 36672	12
10	Hotel at Oak Creek Shopping Center	11
11	Westpark	11
12	Oak Creek Canyon	11
13	94 Unit Apartments on Corydon & Sheets Ln	11
15	Greenspring Hotel	10
16	Baxter & I-15 Mixed Use Project	9
17	Artisan Alley	9
18	Prielipp Apartments	8
19	Orange St. Water & Sewer Improvements	8
21	Grove Park	7
22	Oak Springs Ranch Ph. 2	7
23	Corydon & Grand Mixed Use - APN 370-171-015	6
24	Villa Siena	5

Figure 3.3 Future RW System Demand - Wildomar

-This Page Intentionally Left Blank-

Table 3.7 and Figure 3.4 present the existing five-year maximum historical demands for each month as well as the projected demands for potential future RW customers. Figure 3.4 also displays the recent annual average available flow (including 0.125-mgd Washington Avenue LS flow) of 0.97 mgd, projected annual average available flow (close to 2 mgd by 2045 after bypassing the Greer Ranch and Robards LSs), the maximum instantaneous flow rate (2 mgd) from the TVRWP and the Back Basin wetlands demands capped at the WRF capacity of 2 mgd. Details regarding the projected sewer flow, and thus projected allowable RW flow can be found in Chapter 3 of the EVMWD SSMP. As shown in Table 3.7, average projected RW demand, including the wetlands demands could potentially be as much as 3.1 mgd. Therefore, EVMWD will not be able to supply RW to all potential customers from March to November as potential demand would be higher than available supplies. In December through February, EVMWD would have excess flows without customers desiring the water and would need to waste these flows.

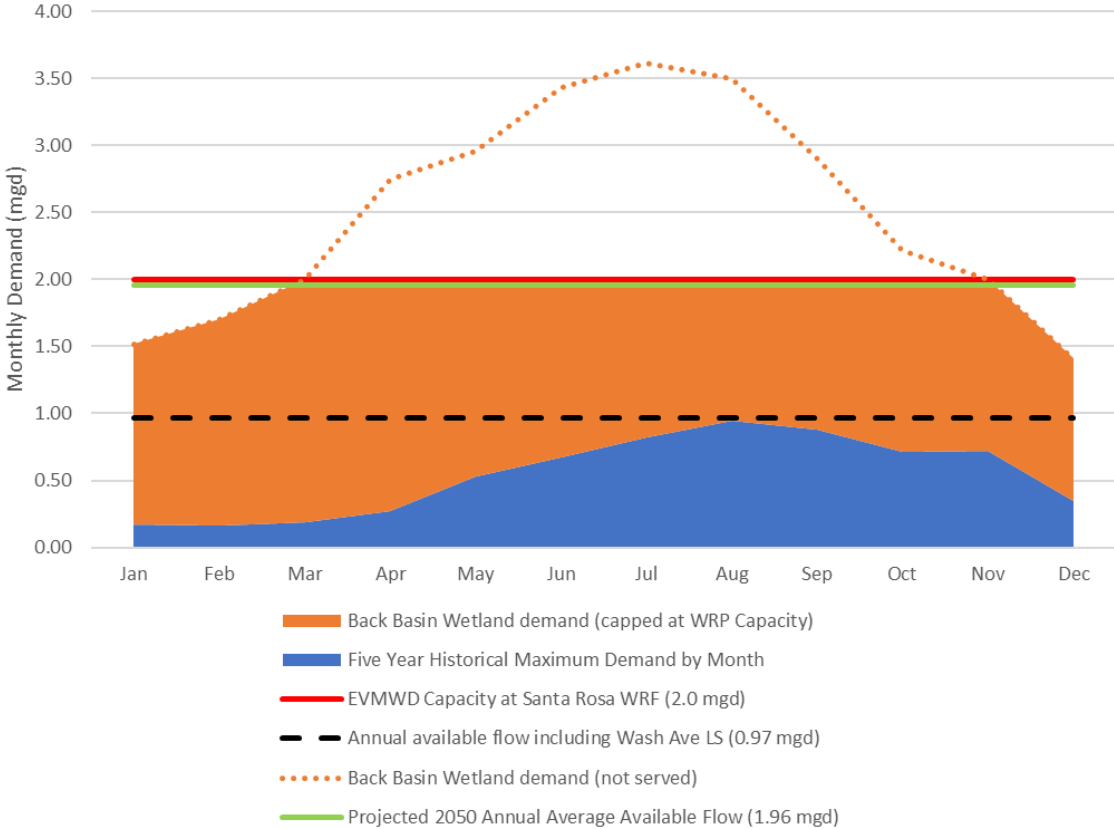

Figure 3.4 Projected RW Demands Based on Five Year Historical Maximum Demand by Month

Table 3.7 Existing and Projected RW Demands for Wildomar Area

Demands	Monthly RW Demand (mgd)												Annual Average (mgd)	Annual Average (AFY)
	January	February	March	April	May	June	July	August	September	October	November	December		
Existing (2017-2021) Maximum Monthly Demands ⁽¹⁾	0.17	0.16	0.19	0.27	0.53	0.67	0.82	0.94	0.88	0.71	0.72	0.35	0.53	594
Future Additional Potential Demands	0.01	0.01	0.01	0.02	0.03	0.04	0.05	0.05	0.05	0.04	0.04	0.02	0.03	34
Back Basin Wetland Demands	1.52	1.70	2.15	2.75	2.96	3.43	3.61	3.49	2.90	2.22	1.77	1.41	2.49	2,790
Total Potential Future Demands	1.70	1.87	2.35	3.04	3.52	4.14	4.47	4.49	3.83	2.98	2.53	1.78	3.05	3,418

Notes:

(1) Source: Customer Billing Data.

3.2.4 Maximum Day Demand and Peak Hour Demand

In addition to evaluating seasonal RW demands, maximum daily and peak hourly demands were also assessed.

Average day demand (ADD), maximum day date, maximum day demand (MDD), and MDD PFs for the Wildomar RW system are listed in Table 3.8. ADD over the past five years has been 0.34 mgd with an average MDD of 1.11 mgd. The MDD to ADD PF has varied significantly from 2.29 to 4.04, with a five-year average of 3.24. It is noted that daily PFs fluctuate significantly on a day-to-day basis due to variable irrigation use by various users. The MDD could be lowered in the future by additional demand management. Therefore, for planning purposes an MDD:ADD PF of 2.7 is used as discussed in the Railroad Canyon PF Section 3.3.6 of this chapter.

Table 3.8 Wildomar MDD:ADD PF by Year

Calendar Year	ADD (mgd)	Maximum Day Date	MDD (mgd)	MDD:ADD PF
2017	0.25	August 29	0.78	3.12
2018	0.38	July 25	0.87	2.29
2019	0.33	October 27	1.33	4.04
2020	0.34	September 14	1.15	3.39
2021	0.42	August 9	1.42	3.35
Five-Year Average (2017-2021)	0.34	-	1.11	3.24

Hourly RW demand analysis was done by evaluating the hourly RW demands from EVMWD’s advanced metering infrastructure (AMI) data for each turnout for the highest demand days during the summer of 2021.

Figure 3.5 through Figure 3.8 show the diurnal patterns for Wildomar Turnout Nos. 1, 2A, 2B, and 5, respectively, using the 2021 AMI data. The diurnal pattern was calculated by comparing demand for each hour to the average daily demand for summer of 2021. Each turnout has a peak demand between 11:00 p.m. and 3:00 a.m. The total system diurnal for Wildomar is shown on Figure 3.9.

EVMWD’s 2005 Rules and Regulations for Recycled Water Use (RW R&R) (Section 4.6, No. 14) specifies RW irrigation hours are from 9:00 p.m. to 6:00 a.m., and therefore most of the RW demand occurs during the night from 9:00 p.m. to 6:00 a.m. This is to minimize evaporation losses and reduce the chance of public contact. The RW R&R does not address non-public contact irrigation systems (such as drip/sub-surface systems) or supervised irrigation with RW, which is allowed by Title 22. Therefore, the existing daytime usage is from managed RW irrigation. Figure 3.8 show that Turnout No. 5 has a lower PF than the rest of the Wildomar

system; this is due to the large portion of RW that is delivered to the Summerly Golf Course, which takes RW during the day to fill ponds on the golf course.

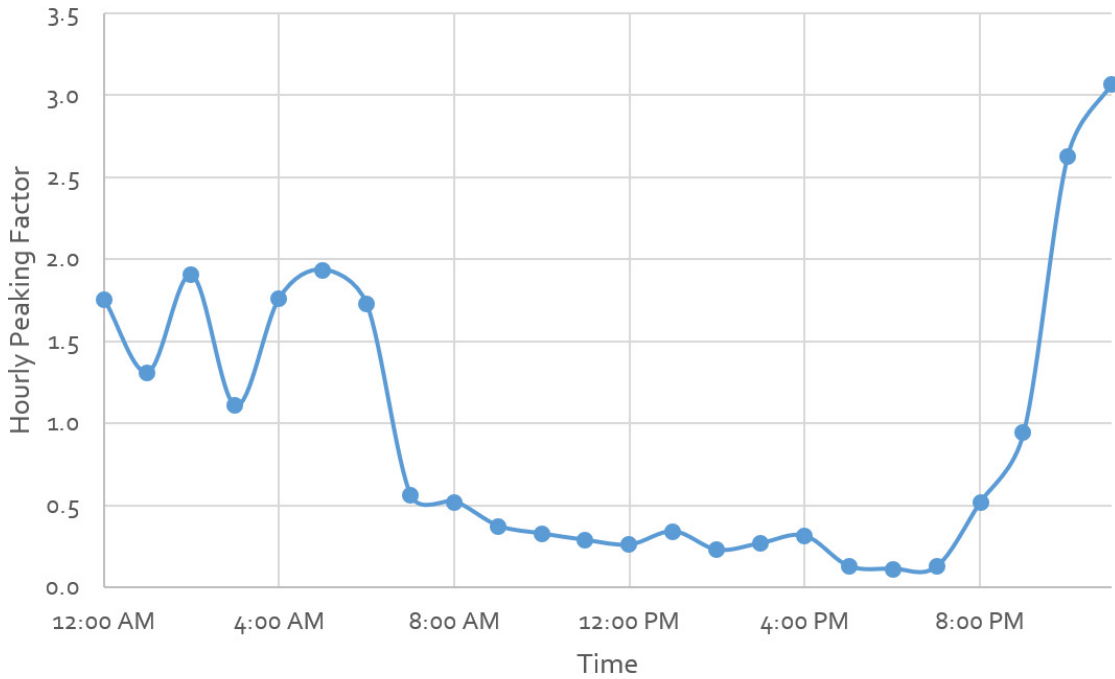

Figure 3.5 Diurnal PFs of Turnout No. 1 for Wildomar Service Area

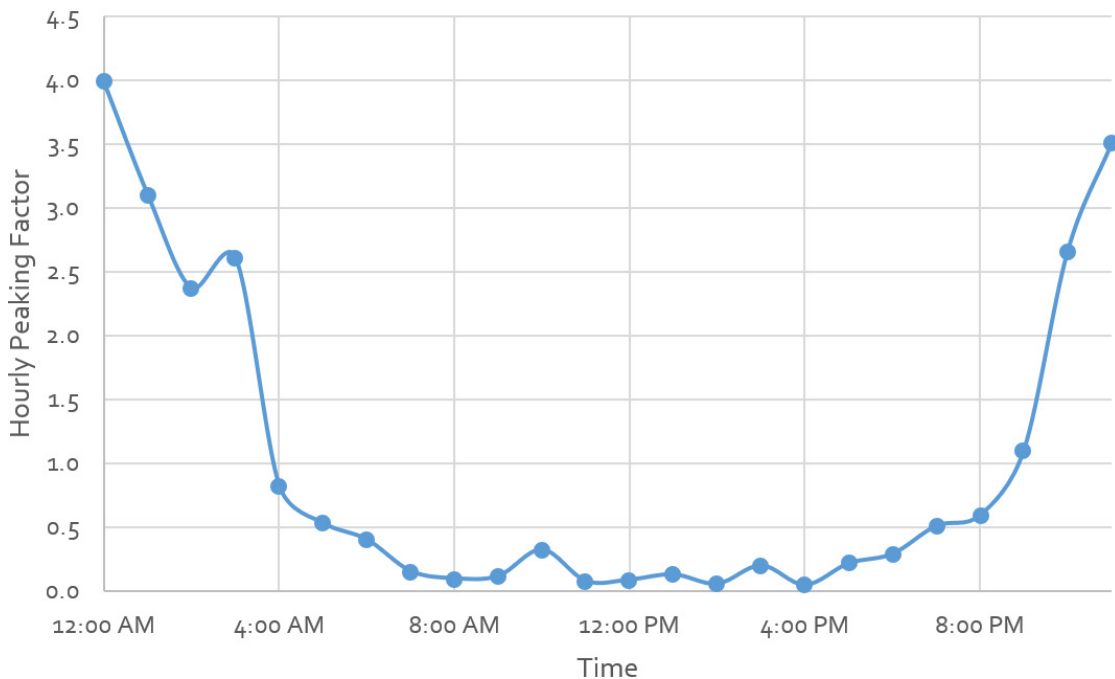

Figure 3.6 Diurnal PFs of Turnout No. 2A for Wildomar Service Area

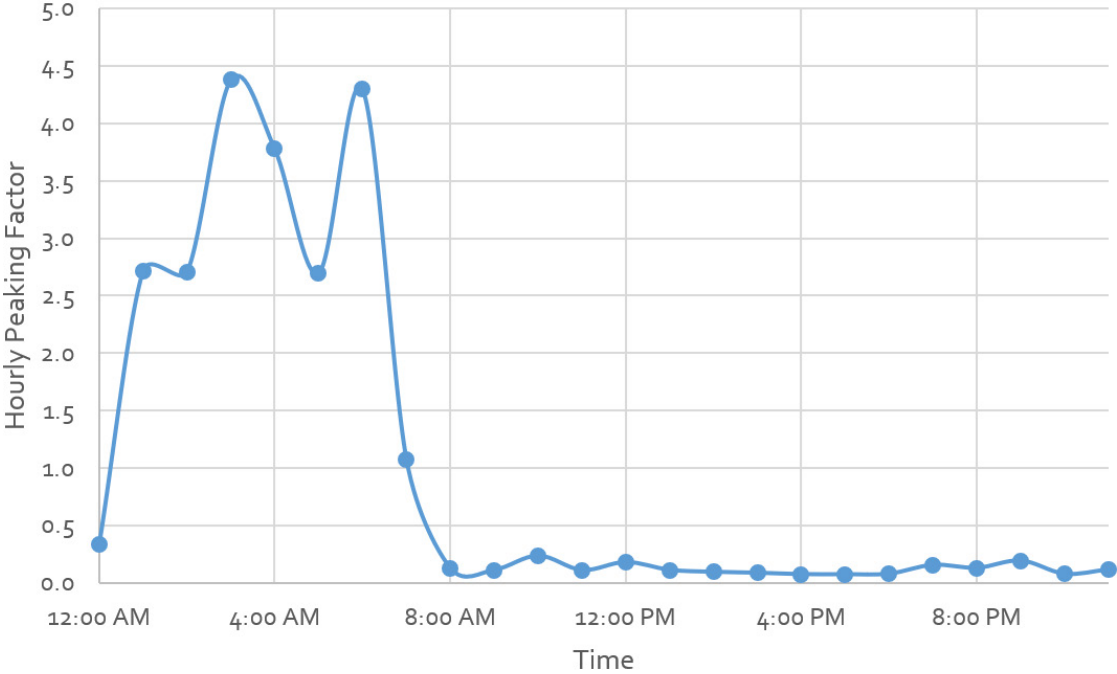

Figure 3.7 Diurnal PFs of Turnout No. 2B for Wildomar Service Area

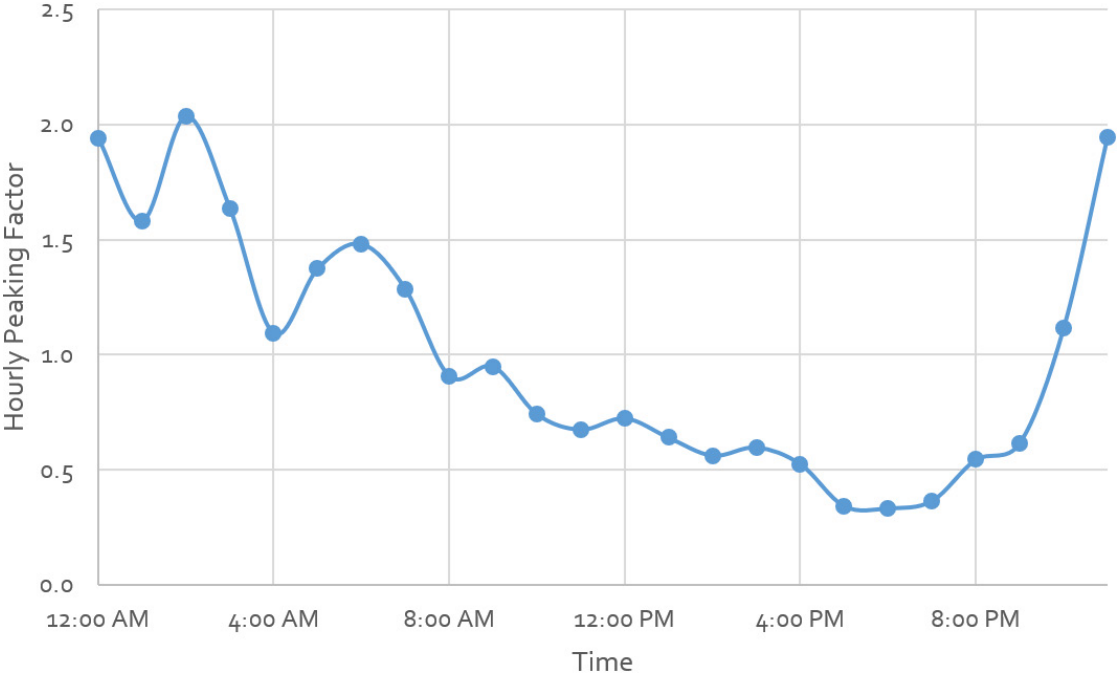

Figure 3.8 Diurnal PFs of Turnout No. 5 for Wildomar Service Area

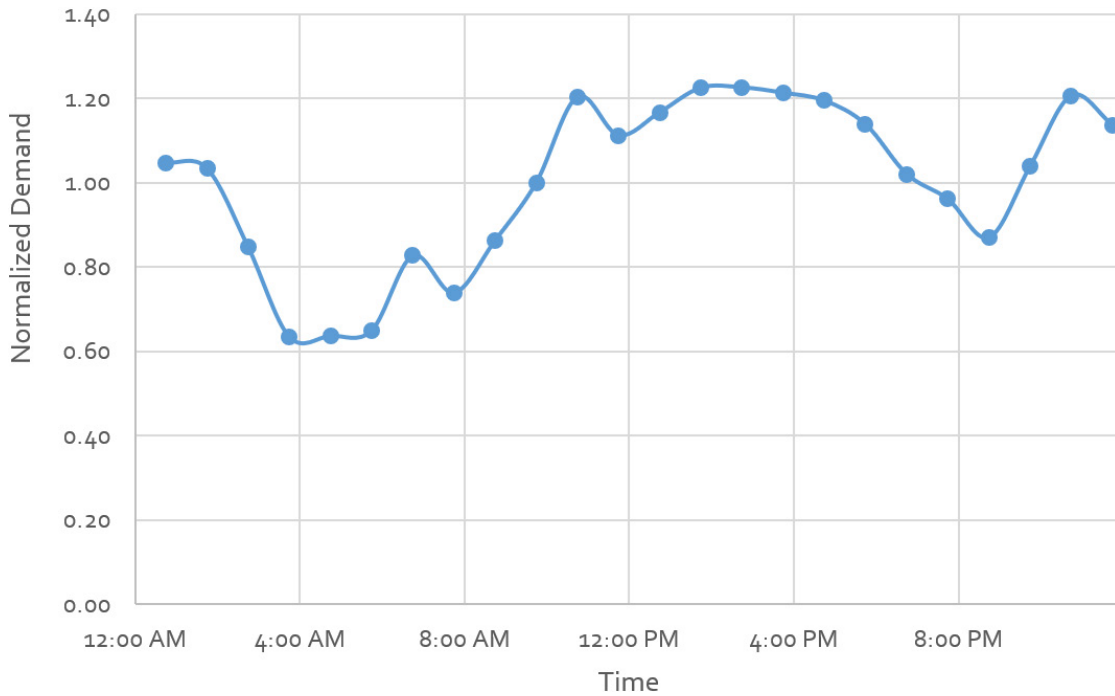

Figure 3.9 Total System Diurnal for Wildomar Service Area

These diurnal curves do not include the future demands of the Wildomar service area, which include the potential expansion projects described in Section 3.1.3. Peak hour demands (PHDs) and their corresponding peak hours for each turnout in the Wildomar system are shown in Table 3.9. PHD:MDD PFs for the system range from 2.18 for Turnout No. 5 to 4.38 for Turnout No. 2B based on the AMI data for all Wildomar turnouts.

Table 3.9 Wildomar PHD:MDD PF by Turnout

Turnout No.	Peak Hour	PHD:MDD PFs
1	11:00 p.m.	3.27
2A	12:00 a.m.	3.98
2B	3:00 a.m.	4.38
5	2:00 a.m.	2.18

3.3 Railroad Canyon Recycled Water Supply and Demand

This section describes the RW supply sources, existing RW customers, estimated future RW demands for the Railroad Canyon system and the seasonal and daily supply and demand analyses for this system.

3.3.1 Recycled Water Supply Source

The Railroad Canyon WRF has a design capacity of 1.3 mgd, but an operational capacity of 1.12 mgd to meet the total inorganic nitrogen 10 milligrams per liter (mg/L) standard. The average inflow into the Railroad Canyon WRF for 2017 through 2021 was 1.03 mgd; however, average inflow to the WRF was temporarily reduced in 2023 to approximately 0.6 mgd until repairs can be made. It should be noted that while some water is lost as waste activated sludge during treatment at the WRF, it is assumed that this loss is not significant enough to impact RW supply availability analysis and thus effluent from Railroad Canyon WRF is generally assumed to be equal to influent to the WRF.

Railroad Canyon WRF does not have sufficient supplies to meet the RW demands in the summer months, although these demands can be met during fall, winter, and spring months. To address this issue, EVMWD has an agreement with EMWD to purchase up to 320 acre-feet of supplemental RW on an annual basis at a peak flow rate of 200 gpm from its Reach 4 pipeline. The Reach 4 pipeline, which is 54 inches in diameter and travels east to west through the Railroad Canyon service area (see Figure 4.4), has a turnout where RW is discharged into the two ponds (Pond Nos. 4 and 5) adjoining Canyon Lake Golf Course (CLGC). These ponds also receive RW pumped from the Railroad Canyon WRF and are used to meet the RW needs of the CLGC and the City of Canyon Lake. The turnout on Reach 4 has metering devices which include supervisory control and data acquisition (SCADA), telemetry capabilities, and pressure and flow monitoring capabilities, which allow EMWD to quantify the amount of RW sold to EVMWD.

Table 3.10 summarizes the Railroad Canyon service area supply sources.

Table 3.10 Railroad Canyon RW Supply Sources

Facility	Capacity	Five-Year Average Flow (mgd)
Railroad Canyon WRF	1.12 mgd	1.03
EMWD Reach 4 agreement with EVMWD	320 AFY annually 200 gpm peak flow (without paying overage rates)	0.14
Potable Supplemental Water	N/A	0.023
Total	N/A	1.19

The Railroad Canyon RW system is served with water from the Railroad Canyon WRF, which has two lined ponds for storing RW before distribution to customers. If there is an insufficient amount of water in the pond, potable water is used to supplement the pond level through an air gap connection.

The Railroad Canyon WRF has the ability to bypass influent wastewater around the plant if it has reached its capacity or less RW is needed. Excess influent is conveyed through a wastewater trunk line to be treated at the Regional WRF. Additionally, the Railroad Canyon WRF discharges via gravity drains the waste active sludge and excess treated effluent directly to the wastewater trunk line to be conveyed to the Regional WRF for treatment. During low demand winter periods, treated effluent bypasses the RW pumps and the two onsite lined RW ponds when they are full. The secondary effluent can also be discharged to the sewer to be conveyed to the Regional WRF for treatment. The five-year average annual secondary effluent sent to the Regional WRF was approximately 195 AFY.

3.3.2 Recycled Water Customers

RW from the Railroad Canyon WRF serves the City of Canyon Lake and the CLGC through a dedicated pipeline and the Canyon Hills community through a separate system referred herein as the Cottonwood system. There are a total of 58 RW customers in the Railroad Canyon system, 56 RW customers served by the Cottonwood system, primarily located along Canyon Hills Road with customers branching off along Lost Road, Cedar Mesa Drive, Hillside Drive, Saddle Hill Road, and Piedmont Drive. A map of existing RW customers can be found on Figure 4.2 in Chapter 4 of this RWSMP.

3.3.3 Available Supply and Historical Demand

Table 3.11 and Figure 3.10 show average monthly RW customer demand data for the past five years (January 2017 to December 2021). The data highlights a seasonal pattern, with the peak demand occurring during the summer months. The historical average RW demands include both the demand for the Canyon Hills community served via the Cottonwood system and the CLGC. As shown on Figure 3.10, the RW demands are seasonal with the five-year average summer demand reaching 1.1 mgd compared to the average annual demand of 0.6 mgd, and a 1.9 maximum month PF. The Cottonwood system accounts for most (approximately 60 percent) of the RW demand of the Railroad Canyon RW system. Both the Cottonwood system and CLGC have a strong seasonal demand pattern with demand in summer months being approximately 2 and 5 times higher than the average and winter demand, respectively.

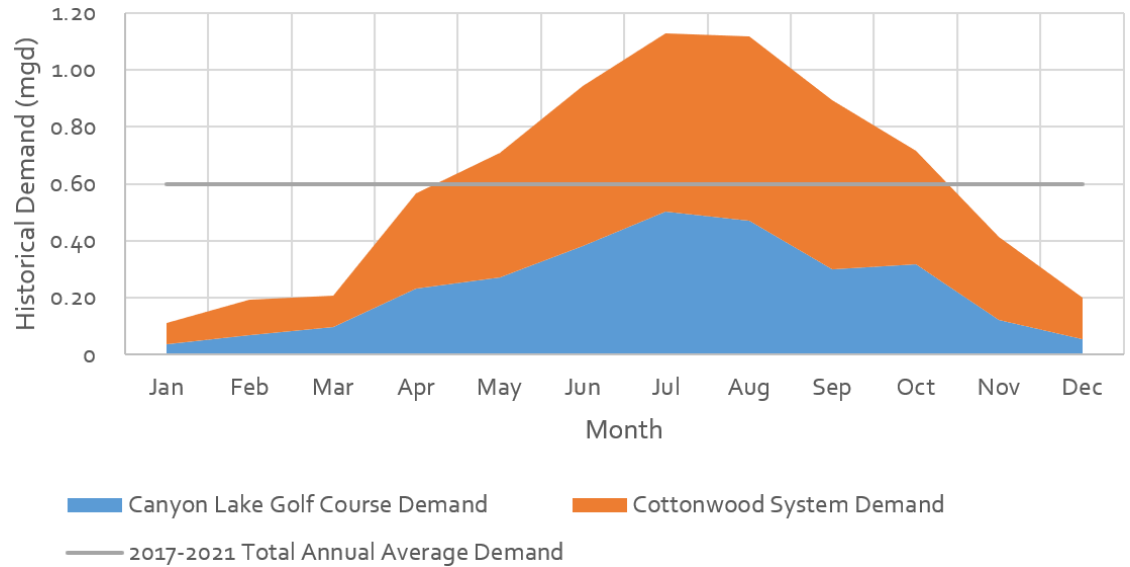

Figure 3.10 2015-2021 Railroad Canyon Average Historical Monthly Demands

The production data from the Railroad Canyon WRF from 2017 to 2021 is shown on Figure 3.11. The water supply required to meet the demand in the Railroad Canyon service area can be divided into four parts:

1. RW pumped from Railroad Canyon WRF to Canyon Hills.
2. RW pumped from Railroad Canyon WRF to the golf course.
3. Flow from EMWD used at the golf course. The existing wholesale purchase agreement with EMWD restricts the RW flow rate to 200 gpm and supply up to 320 AFY. Due to hydraulic limitations, the RW from EMWD is only available for the CLGC and not the Canyon Hills customers.
4. Potable supplemental water required to keep the effluent pond full enough to meet RW demands. The potable supplemental water is mixed with RW to meet RW demands.

Table 3.11 2017-2021 Average Historical Monthly Demands

Demand	Month												Average
	January	February	March	April	May	June	July	August	September	October	November	December	
Average Cottonwood System Demand (mgd)	0.08	0.13	0.11	0.33	0.43	0.56	0.63	0.65	0.60	0.40	0.29	0.14	0.36
Average CLGC Demand (mgd)	0.04	0.07	0.10	0.23	0.27	0.38	0.50	0.47	0.30	0.32	0.12	0.06	0.24
Average Total Demand (mgd)	0.11	0.19	0.21	0.57	0.71	0.94	1.13	1.12	0.89	0.72	0.41	0.20	0.60
Monthly PF	0.19	0.32	0.35	0.94	1.18	1.57	1.88	1.86	1.49	1.20	0.69	0.33	

Figure 3.11 shows that during the summer and fall months, the total non-potable demand (consisting of flows pumped to CLGC and Cottonwood) exceeds the influent flow into the Railroad Canyon WRF. Therefore, additional supply is required to meet the demand. During the summer months, RW is purchased from EMWD to meet increased RW demands. During low demand periods, EVMWD also discharges the excess Railroad Canyon WRF effluent into the sewer to be treated at the Regional WRF, bypassing flows to Regional WRF only when there is a surplus of RW supplies compared to demand, the ponds are full, and there is no other option to dispose of the effluent.

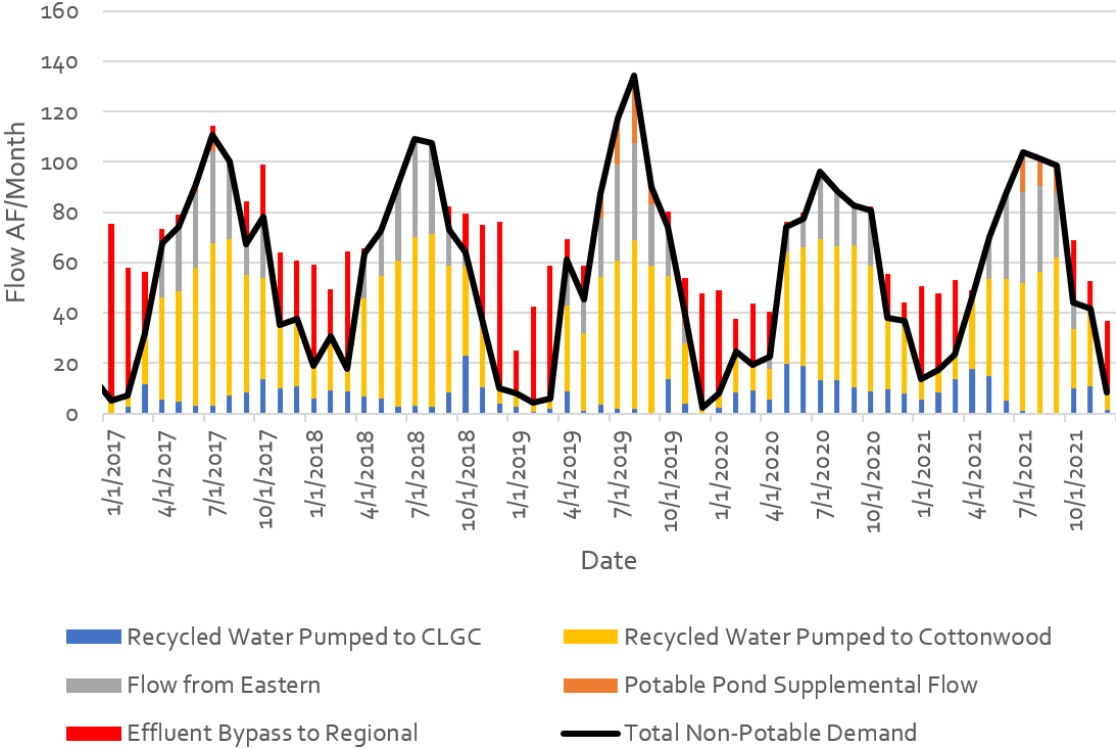

Figure 3.11 Railroad Canyon Historical RW Consumption and Uses

The diurnal patterns for different customers based on AMI data are included in Appendix D.

3.3.4 Future Recycled Water Demand

Using the same methodology to identify potential future RW demands described in Section 3.1.3, one potential future RW user was identified in the Railroad Canyon service area that met the criterion of a minimum potential RW demand of 5 AFY as shown on Figure 3.12. As shown in Table 3.12, this customer is the Railroad Canyon Mixed Use project with an estimated RW demand of 8 AFY. Since projected future demands are less than one percent of the existing RW demands, the addition of this customer does not have a significant impact on the RW supply and demand balance for the Railroad Canyon system. Future wastewater flows to the Railroad Canyon WRF are not expected to change significantly in the future.

Table 3.12 Railroad Canyon Potential RW Customer

Customer Number	Customer/Planned Development Name	Potential Future Demand (AFY)	Potential Future Demand (mgd)	Existing Potable Customer or Planned Development
1	Railroad Canyon Mixed-Use	8	0.007	Planned Development
Total		8	0.007	

3.3.5 Seasonal Demand Variability

To assess the Railroad Canyon system's capacity to serve current and potential future customers, the projected demands were distributed among the 12 months by evaluating historical data and determining the percentage of total demands occurring in each month.

Table 3.13 and Figure 3.13 present the existing five-year maximum monthly historical demands as well as the projected demands for the future developments. Figure 3.13 compares the total projected demand with the 2017-2021 average flow from Railroad Canyon WRF (1.03 mgd), the projected 2050 flow from Railroad Canyon WRF (1.4 mgd), and the Railroad Canyon WRF Capacity (1.12 mgd). Table 3.7 shows the expected monthly surplus or deficit between the projected flow available from the Railroad Canyon WRF in 2050 and the total potential future RW demand. For more information on the projected sewer flow, refer to Chapter 3 of the EVMWD SSMP. Note that the sewer flow for the Railroad Canyon system is not expected to increase or change significantly in the future.

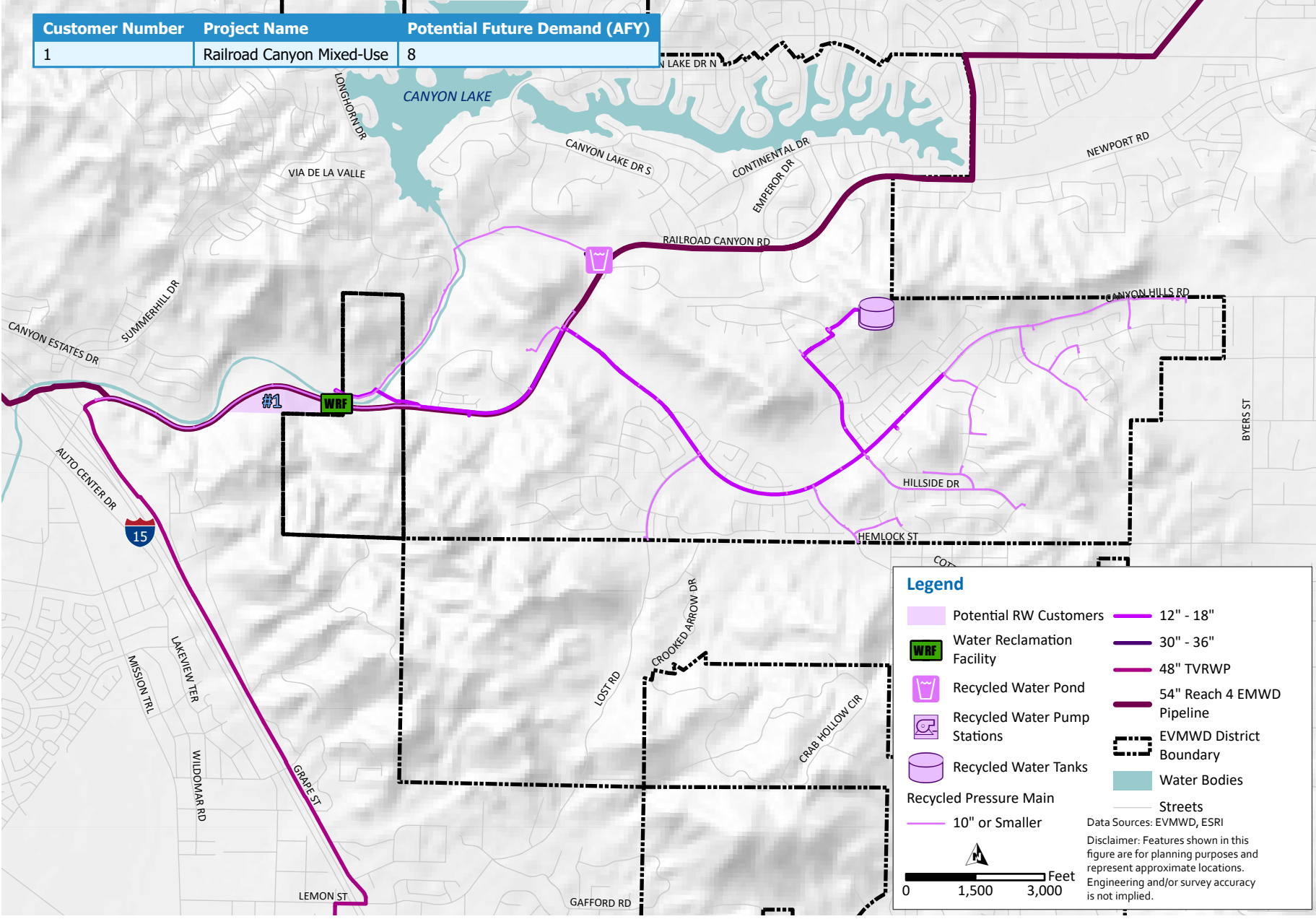

Figure 3.12 Future RW System Demand - Railroad Canyon

-This Page Intentionally Left Blank-

Table 3.13 Existing and Projected RW Demands for Railroad Canyon Area

Demand	Month (mgd)												Annual Average (mgd)	Annual Average (AFY)
	January	February	March	April	May	June	July	August	September	October	November	December		
Existing (2017-2021) Maximum Monthly Demands ⁽¹⁾	0.20	0.36	0.36	0.73	0.84	1.05	1.31	1.42	1.07	0.92	0.50	0.39	0.76	851
Future - Railroad Canyon Potential NPR Project 1	0.002	0.003	0.003	0.007	0.008	0.010	0.012	0.013	0.010	0.009	0.005	0.004	0.007	8
Total - Existing Five Year Maximum Month And Future Demands	0.20	0.36	0.36	0.74	0.85	1.06	1.33	1.44	1.08	0.93	0.51	0.40	0.77	863
Expected Surplus/Deficit With Projected 2050 Allowable Flow (1.04 mgd)	0.84	0.68	0.68	0.30	0.19	-0.02	-0.29	-0.40	-0.04	0.11	0.53	0.64	0.27	302

Notes:
 Abbreviations: NPR - non-potable reuse.
 (1) Source: Customer Billing Data.

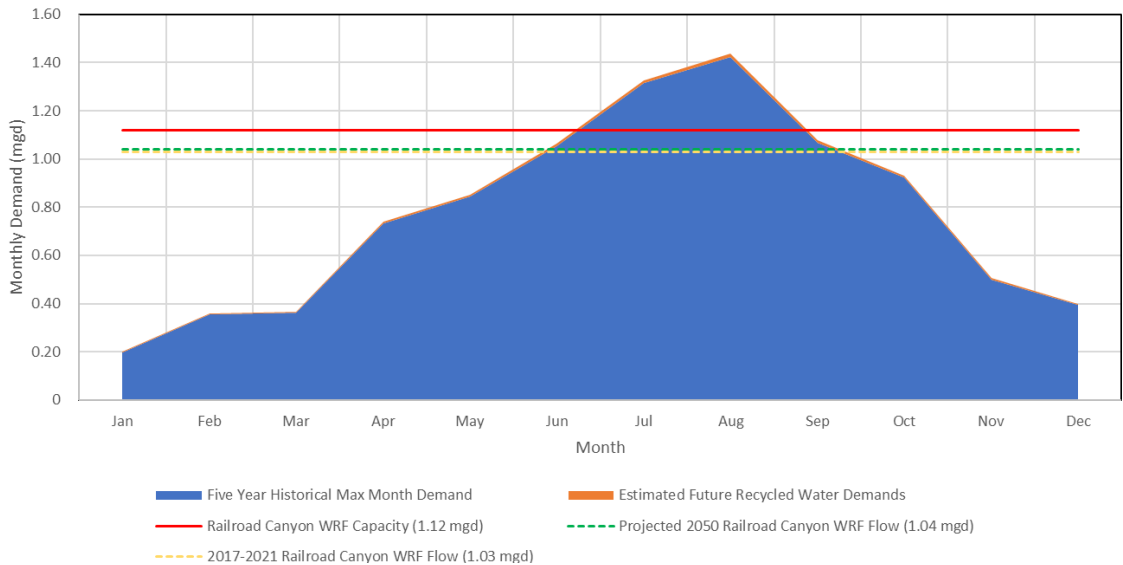

Figure 3.13 Railroad Canyon Projected RW Demands Based on Five-Year Historical Maximum Demand for Each Month

The projected future maximum monthly demand is expected to follow historical patterns and exceed available Railroad Canyon WRF flow as well as plant capacity from June through September. The total annual volume of water that is expected to surpass the average effluent from the Railroad Canyon WRF is approximately 71 AFY. The required volume of water needed was calculated by taking the difference between the projected demand (maximum monthly demand from 2017-2021 and projected future customer use) and the projected available supply (2017-2021 average Railroad Canyon WRF effluent amount plus additional flow to account for growth) for each month and multiplying by the number of days in the month. This value can also be visualized as the total area above the average Railroad Canyon WRF effluent line but below the demand line on Figure 3.13. If EVMWD increased the average influent of the Railroad Canyon WRF to the capacity of Railroad Canyon WRF (1.12 mgd), EVWMD would still require 41 AFY of supplemental potable water or purchased water from EMWD.

Apart from evaluating the supplemental water required during the maximum demand summer months, an evaluation was conducted to determine how much raw wastewater is expected to bypass the Railroad Canyon WRF during the winter months when RW demand is less than available flow from the Railroad Canyon WRF. The volume of expected bypass water was calculated by taking the difference between the projected available supply and the projected demand for each month from October through May and multiplying by the number of days in the month. This value can be visualized as the total area below the Railroad Canyon WRF flow

line but above the projected demand on Figure 3.13. In total, approximately 390 AFY of water is expected to bypass the Railroad Canyon WRF in the future.

3.3.6 Maximum Day Demand and Peak Hour Demand

The MDD for the Cottonwood system was determined from the daily data on how much water was pumped to Canyon Hills development throughout one year. The MDD in 2021 was July 21 with a demand in the Cottonwood system of 0.88 mgd. The ADD for the Cottonwood system for 2021 was 0.33. Thus, the MDD to ADD PF for 2021 was found to be 2.63. The ADD is determined from the annual average demand from the production data. The MDD and ADD is summarized in Table 3.14. For planning purposes, to be conservative, an MDD:ADD PF of 2.7 is recommended for future planning.

Table 3.14 2021 Cottonwood (Canyon Hills) MDD:ADD PF

ADD (mgd)	MDD (mgd)	MDD:ADD PF
0.33	0.88	2.63

Similar to the Wildomar system, a diurnal curve was developed for the Cottonwood (Canyon Hills) system based on the summer 2021 AMI data for 63 meters received from EVMWD as shown on Figure 3.14. As shown in Table 3.15, this system peaks at 11:00 p.m. with a PHD:MDD PF of 2.30.

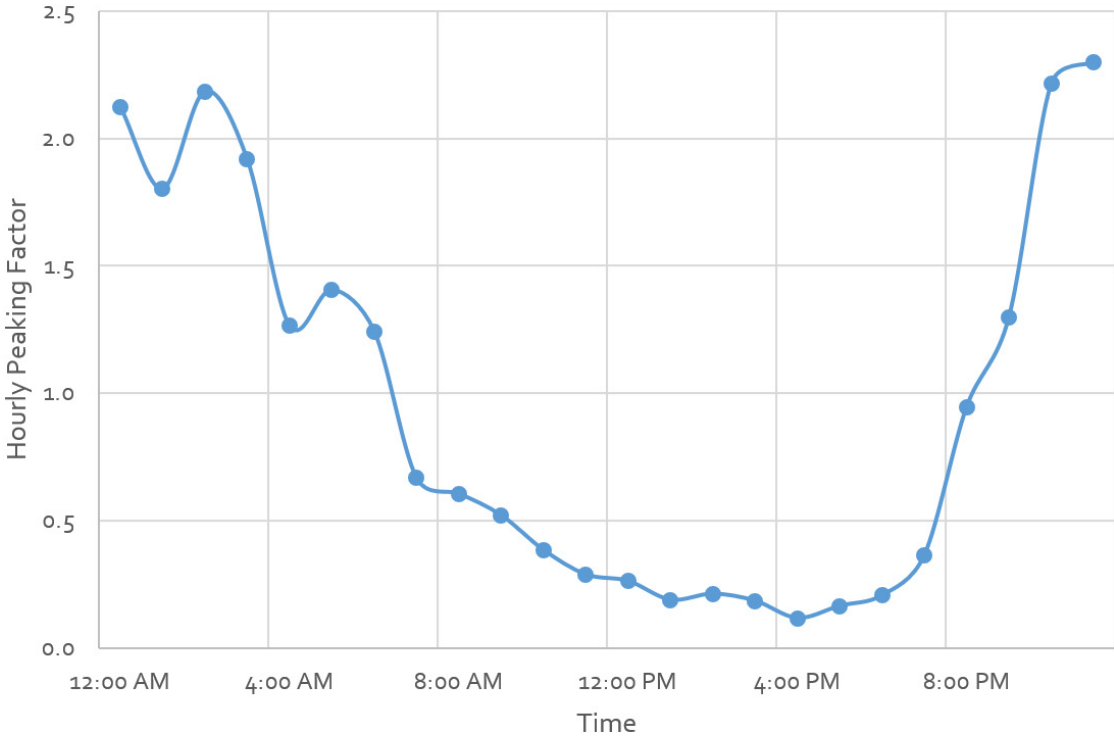

Figure 3.14 RW PF Diurnal Curve of Cottonwood (Canyon Hills) Service Area

Table 3.15 Railroad Canyon PHD:MDD PF

Peak Hour	PHD:MDD PF
11:00 p.m.	2.30

3.4 Horsethief Canyon Recycled Water Supply and Demand

This section first describes the RW supply source, existing RW customers, and the estimated future RW demands for the Horsethief system. Subsequently, the seasonal and daily supply and demand analyses for this system are described.

3.4.1 Recycled Water Supply Source

The Horsethief WRF receives wastewater from the surrounding areas and treated approximately 0.35 mgd on average from 2017 to 2021 with a capacity to treat 0.5 mgd average daily flow. Planned expansion at the Horsethief WRF will increase the plant’s capacity from approximately 0.3 mgd to a total of 0.8 mgd to accommodate pending developments in the area. The mid-term (2030) and long term (2050) flow projections estimate the flow from Horsethief WRF to be 0.56 mgd and 0.65 mgd, respectively. As the evaluation considered RW availability based on the flow of the effluent pump station, the flows lost via the waste activated sludge generated during treatment at the WRF have been accounted for. The Horsethief WRF produces RW meeting California Title 22 quality standards and stores the treated water in the single lined on-site storage pond.

If RW supply from the Horsethief WRF is not sufficient to meet RW demand, potable makeup water can be used. RW in the Horsethief service area was formerly augmented by water pumped from the Barney Lee Well and currently can be supplied by potable supplemental water. Table 3.16 summarizes the Horsethief service area supply sources.

Table 3.16 Horsethief RW Supply Sources

Facility	Capacity (mgd)	Average Production (mgd)
Horsethief WRF	0.5	0.35
Barney Lee Well	Unknown ⁽¹⁾	0.00 ⁽²⁾

Note:

- (1) The Horsethief Canyon WRF RW ponds have a supplemental source of irrigation water from Barney Lee Well, if required. The maximum historical usage from this well was 0.4 mgd, which occurred in August 2000. Potable supplemental water at Mid-Range Pump Station (MRPS) capacity unknown, average production 0.00 mgd.
- (2) The Barney Lee Well has not been consistently used since 2008 and was not used between 2017 and 2021. In 2022, the Barney Lee Well supplied 0.3 acre-feet to the Horsethief WRF system.

3.4.2 Recycled Water Customers

The Horsethief Canyon service area includes 30 RW customers with a combined average demand of 225 AFY (0.20 mgd). These customers are located along Silver Stirrup Drive, Mountain Road, and Horsethief Canyon Road. A map of existing RW customers can be found on Figure 4.6 in Chapter 4 of this RWSMP.

3.4.3 Available Supply and Historical Demand

The Horsethief Canyon WRF has had a consistent seasonal flow and pattern from 2017 to 2021 as depicted on Figure 3.15. Over the past five years, the Horsethief Canyon WRF produced a relatively consistent flow of approximately 0.35 mgd, and RW demand peaks at about 0.31 mgd during the summer months and drops to about 0.05 mgd during the winter months. Figure 3.15 shows the Horsethief Canyon WRF effluent flow rate as well as the existing and future treatment capacities. Additionally, the average historical RW demand derived from the customer billing data from 2017 to 2021 is shown. Average monthly RW supply and demand are shown in Table 3.17. The Horsethief Canyon WRF is currently able to meet the peak summer RW demands if production exceeds 0.33 mgd.

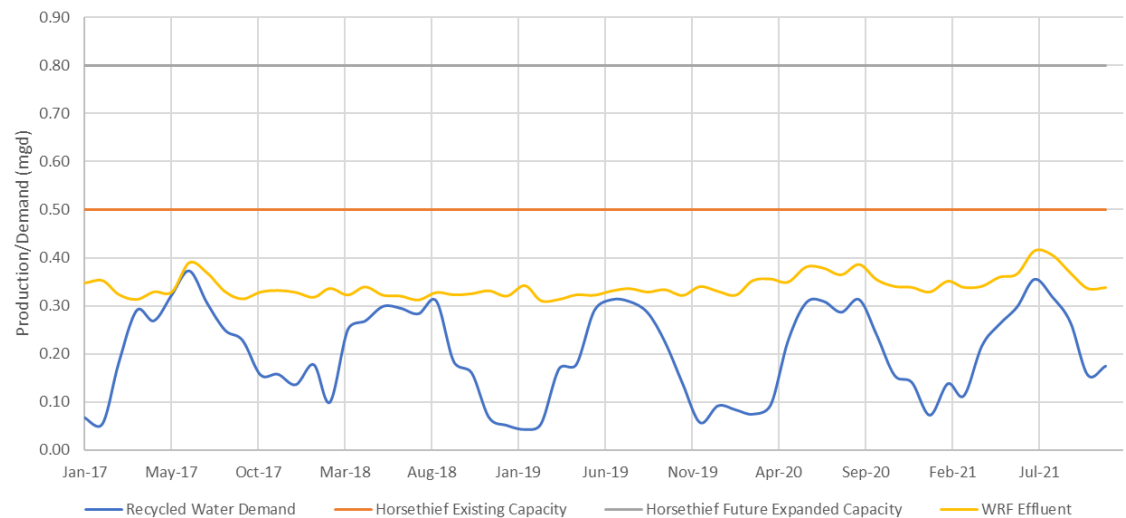

Figure 3.15 2017-2021 Horsethief RW Production and Demand

3.4.4 Future Recycled Water Demand

Future potential RW demand associated with planned developments and existing potable customers for the Horsethief area was estimated using the same methodology described in Section 3.1.3. In addition, four developments (Saddleback Estates, JBJ Ranch, SAM [formerly Horsethief Canyon], and Renaissance Ranch) are planned for construction in the mid-term (assumed to occur by 2030). The developers associated with these projects have provided their estimated RW demand, demand associated with park irrigation, and/or detailed site drawings illustrating planned irrigated acreage. Estimated RW demand associated with these mid-term developments have been calculated as summarized in Table 3.18.

Table 3.17 2017-2021 Horsethief Average Supply and Demand by Month

Supply and Demand	Month												Average
	January	February	March	April	May	June	July	August	September	October	November	December	
Average Supply (mgd)	0.35	0.35	0.36	0.36	0.35	0.35	0.34	0.34	0.35	0.35	0.38	0.37	0.35
Average Demand (mgd)	0.08	0.10	0.10	0.21	0.24	0.30	0.33	0.30	0.28	0.21	0.16	0.10	0.20
Monthly Demand PF	0.41	0.49	0.52	1.04	1.19	1.50	1.63	1.49	1.41	1.02	0.78	0.51	

As shown in Table 3.18, the total demand associated with these mid-term developments are 128 AFY. Long-term planned developments are assumed to be constructed after 2030 but before 2050. These developments are estimated to have 17 AFY of additional RW demand. Total future additional RW demand in the Horsethief area is estimated to be 145 AFY, which equates to an ADD of 0.13 mgd as shown on Figure 3.16.

Table 3.18 RW Demands of Horsethief Canyon Potential Non-Potable Expansion Customers

Customer Number	Customer/Planned Development Name	Potential Future Demand (AFY)	Potential Future Demand (mgd)	Existing Potable Customer or Planned Development
Mid-Term Developments				
1	JBJ Ranch ⁽¹⁾	51	0.046	Planned Development
2	Saddleback Estates ⁽²⁾	48	0.043	Planned Development
3	Renaissance Ranch Commerce Center ⁽³⁾	20	0.018	Planned Development
4	SAM ⁽³⁾	9	0.008	Planned Development
Mid-Term Subtotal		128	0.114	
Long-Term Developments				
4	Sycamore Creek Marketplace	9	0.008	Planned Development
5	Horsethief Ridge Tract 37002	8	0.007	Planned Development
Long-Term Subtotal		17	0.015	
Total		145	0.129	

Notes:

- (1) RW demand is estimated to be 51 AFY. (KWC Engineers 2022).
- (2) RW demand is estimated to be 48 AFY. (Dexter Wilson Engineering 2022).
- (3) RW demand is estimated by multiplying total irrigated acreage for each development by the park irrigation duty factor of 2,300 gallons per day per acre. Renaissance Ranch is estimated to have approximately 7.7 acres of irrigated parks and SAM is estimated to have approximately 3.4 acres of irrigated parks.

3.4.5 Seasonal Demand Variability

To assess the Horsethief system's capacity to serve these potential future customers, the projected demands listed in Table 3.18 were converted to monthly demand estimates using monthly PFs derived from historical RW demand data.

Table 3.19, Figure 3.17, and Figure 3.18 show the existing five-year maximum monthly historical demands as well as the projected demands for the future mid-term and longer-term developments. Figure 3.17 includes a comparison of the total projected demand as well as the 2017-2021 average flow (0.25 mgd), projected 2030 flow (0.56 mgd) from Horsethief Canyon WRF. Figure 3.18 shows a comparison of the projected 2030 flow (0.56 mgd) and projected 2050 flow (0.65 mgd) from Horsethief Canyon WRF. Figure 3.15 also includes the current (0.5 mgd) and expanded (0.85 mgd) Horsethief Canyon WRF capacity. The expected monthly surplus or deficit between the projected flow available from the Horsethief Canyon WRF in 2030 and in 2050 and the mid-term and longer-term future RW demand is also shown in Table 3.19. See Chapter 3 of the EVMWD SSMP for details regarding the projected sewer flow, and thus projected allowable RW flow.

As shown on Figure 3.17, near term RW demand is not expected to exceed mid-term WRF flow though it may be close to utilizing all flow available in June and July.

The 2050 flows available from Horsethief Canyon WRF with the expanded Horsethief Canyon WRF capacity are sufficient to provide for the projected long-term RW demands except in the month of July. As shown in Table 3.19, the monthly RW supply deficit in the months is projected to reach 0.09 mgd in 2050.

These long-term RW demands should be refined as specific areas or projects develop and more details about the developments are available to reassess the availability of RW to meet those demands.

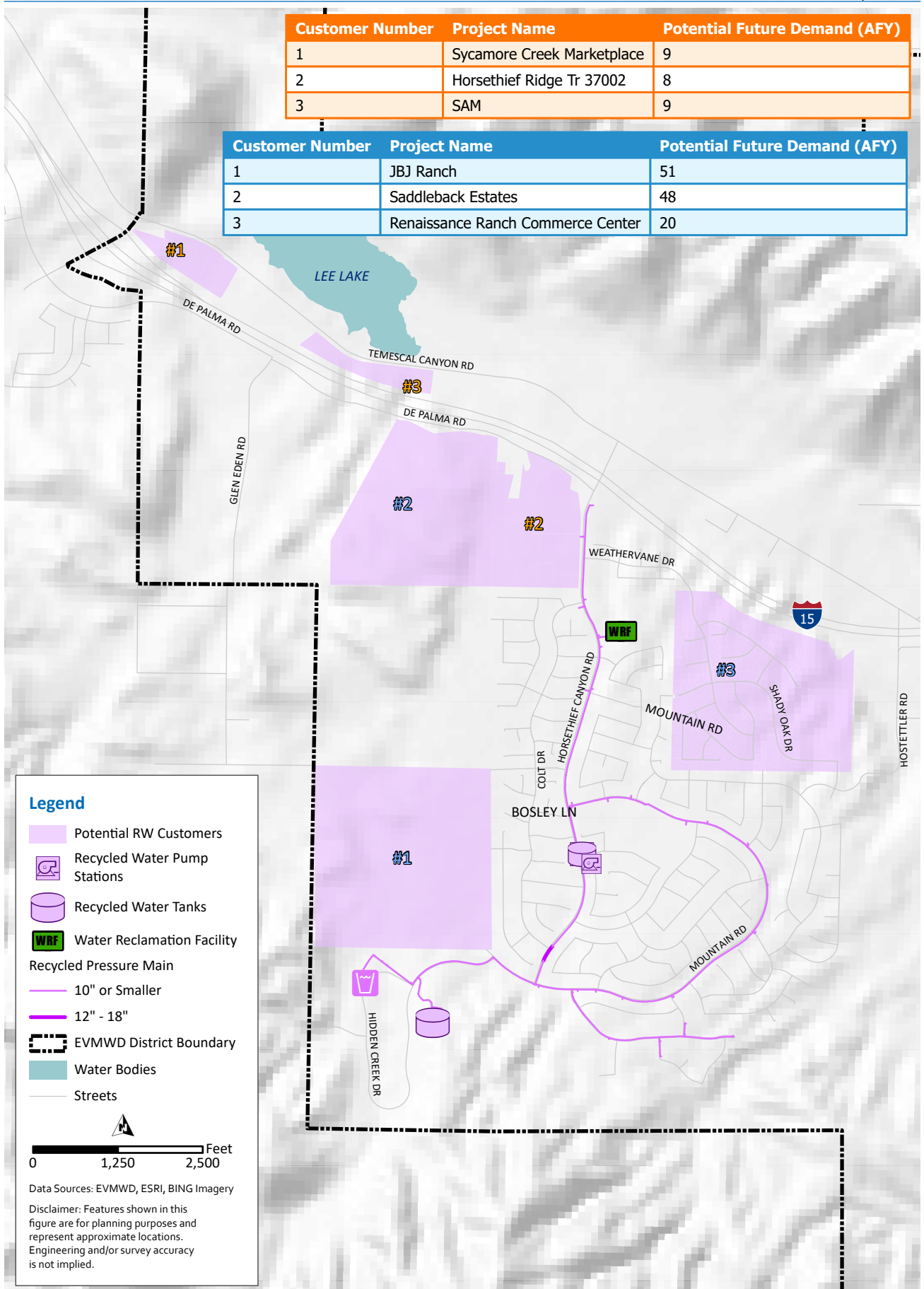

Figure 3.16 Future RW System Demand - Horsethief

-This Page Intentionally Left Blank-

Table 3.19 Existing and Projected RW Demands for Horsethief Area

Demand	Month (mgd)												Annual Average (mgd)	Annual Average (AFY)
	January	February	March	April	May	June	July	August	September	October	November	December		
Existing (2017-2021) Maximum Monthly Demands ⁽¹⁾	0.14	0.18	0.18	0.32	0.27	0.32	0.37	0.32	0.31	0.24	0.17	0.16	0.25	280
Potential Mid-Term Developments ⁽²⁾	0.06	0.08	0.08	0.15	0.12	0.15	0.17	0.15	0.14	0.11	0.08	0.07	0.11	123
Potential Long-Term Developments ⁽³⁾	0.07	0.09	0.09	0.17	0.14	0.17	0.19	0.17	0.16	0.12	0.09	0.08	0.13	146
Mid-Term Demands	0.20	0.26	0.26	0.47	0.39	0.47	0.54	0.46	0.46	0.35	0.25	0.23	0.36	528
Long-Term Demands	0.21	0.27	0.28	0.49	0.41	0.49	0.57	0.48	0.48	0.36	0.26	0.24	0.38	549
Expected Surplus/Deficit with Projected 2025 Available Flow (0.47 mgd)	0.36	0.30	0.30	0.09	0.17	0.09	0.02	0.10	0.10	0.21	0.31	0.33	0.20	224
Expected Surplus/Deficit with Projected 2050 Available Flow (0.63 mgd)	0.38	0.30	0.29	0.01	0.12	0.01	-0.09	0.02	0.03	0.18	0.31	0.34	0.16	179

Notes:

- (1) Source: Customer Billing Data: maximum demand per month from 2017-2021.
- (2) Mid-term developments are expected to be constructed within the next five years.
- (3) Longer-term developments are expected to be constructed further into the future than five years, but before 2050.

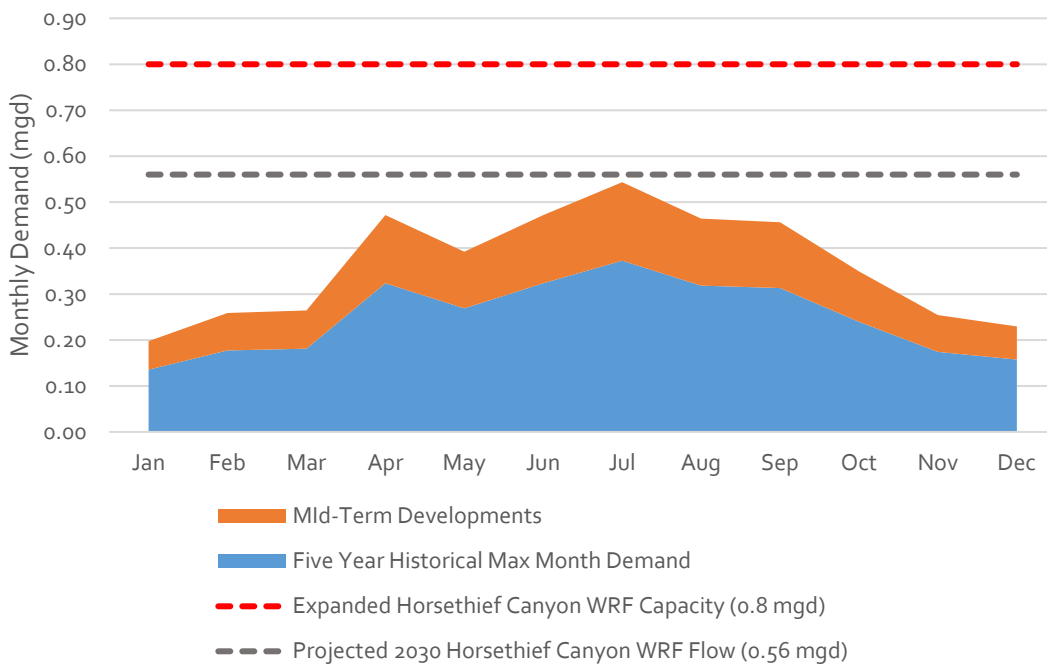

Figure 3.17 Horsethief Projected RW Mid-Term Supplies and Demands (Year 2030)

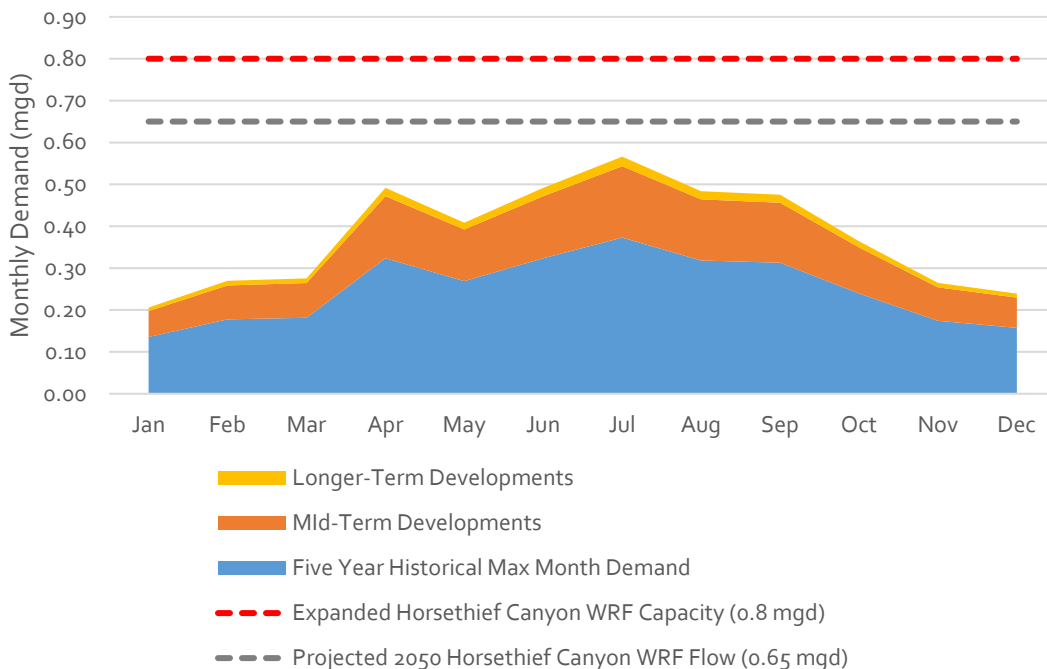

Figure 3.18 Horsethief Canyon Projected RW Long-Term Supply and Demands (Year 2050)

3.4.6 Maximum Day Demand and Peak Hour Demand

Daily demand data is not available for the Horsethief system as the effluent from the Horsethief WRF is not equal to RW demand as excess RW is conveyed through the same pump station as RW demands, eventually ending at the percolation pond, which is not metered daily. The MDD:ADD PF calculation method and results for the Wildomar system is discussed in Section 3.2.4. Since daily demand data for the Horsethief system was not available and the Cottonwood system serves similar irrigation demands as the Horsethief system, the MDD:ADD PF calculated for the Cottonwood system component of Railroad Canyon WRF effluent is assumed to apply to the Horsethief system. Thus, for the MDD:ADD PF criteria for the Horsethief system for planning purposes is recommended as 2.7, same as the Railroad Canyon system.

Similar to the Wildomar system, the diurnal curve was developed for the Horsethief system based on the summer 2021 AMI data for 30 meters received from EVMWD as shown on Figure 3.19. As shown in Table 3.20, the peak for this system occurs around 10:00 p.m. with a PF of 2.72.

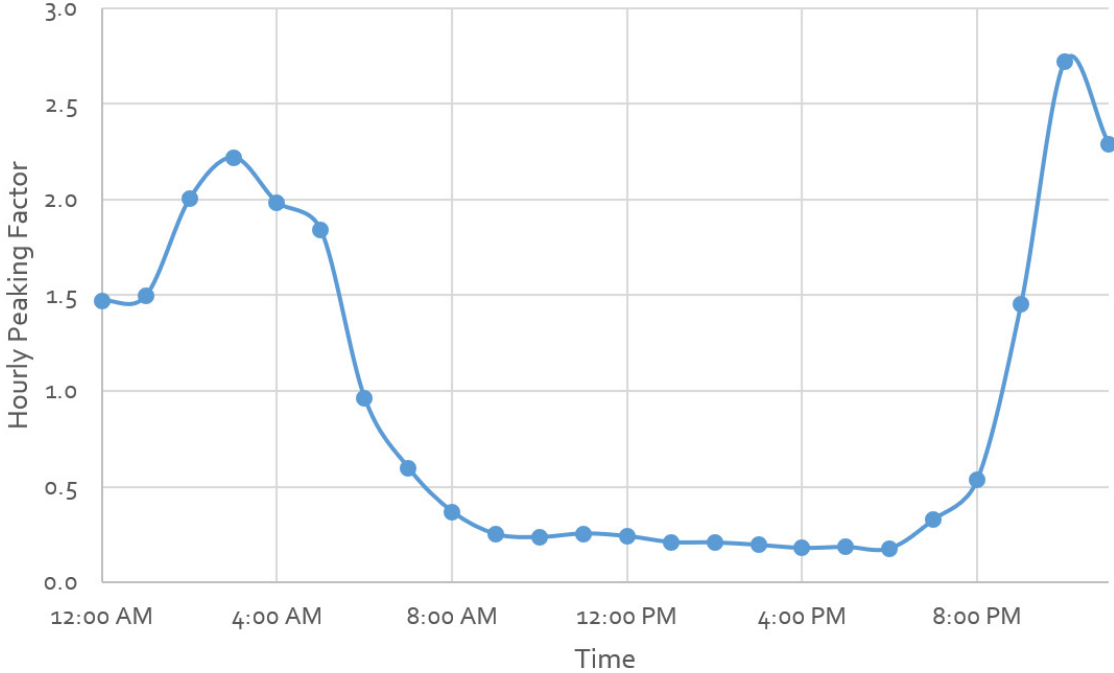

Figure 3.19 Diurnal Curve of Hourly PF of Horsethief Service Area

Table 3.20 Horsethief PHD:MDD PF

Peak Hour	PHD:MDD PF
10:00 p.m.	2.72

3.5 Regional Recycled Water Supply and Demand

This section first describes the RW supply source, existing RW customers, and the estimated future RW demands for the Regional system. Subsequently, the seasonal and daily supply and demand analyses for this system are described.

3.5.1 Regional Recycled Water Supply Source

EVMWD owns and operates the Regional WRF. The existing Regional WRF has an average design capacity of 8.0 mgd and produces an average of 6.1 mgd, as shown in Table 3.21. The Regional WRF discharges treated Title 22 effluent to Lake Elsinore and to Temescal Creek. EVMWD is required to discharge 0.5 mgd to the Temescal Creek to maintain downstream riparian habitat. Under current typical operations, the remaining plant flow is discharged to Lake Elsinore to maintain the level of Lake Elsinore at a minimum elevation of 1,240 feet above mean sea level (ft-msl) year-round. When the lake level exceeds 1,247 ft-msl, RW can no longer be discharged to the lake and the entire plant flow is discharged to Temescal Creek. A small portion of the Regional WRF RW is used for landscape irrigation at the Regional WRF facility and surrounding office building. This demand is less than 5 AFY.

Table 3.21 Regional RW Supply Source

Facility	Average Design Capacity (mgd)	Average Production (mgd)
Regional WRF	8.0	6.1

3.5.2 Available Supply and Historical Demand

The planned expansion of the Regional WRF will increase total capacity to 12 mgd (average daily flow) within the next several years. Based on the proposed total maximum daily load (TMDL) requirement for discharge to Lake Elsinore, it is assumed that 7.5 mgd of effluent from the Regional WRF is required to maintain minimum water levels in Lake Elsinore. Additionally, 0.5 mgd is needed to continue to meet the Temescal Wash discharge requirements. Thus, approximately 4.0 mgd of treatment capacity at the future expanded Regional WRF is expected to be available to potentially serve additional RW customers in the Regional or Wildomar areas or for use as part of EVMWD’s planned indirect potable reuse (IPR) program. EVMWD recently evaluated the possibility of utilizing additional product water from the Regional WRF for an IPR water supply. The results of this analysis recommended an IPR via groundwater injection well project or taking the IPR product water to blend in Canyon Lake and then be treated at the Canyon Lake Water Treatment

Plant for potable water supply (Kennedy/Jenks Consultants 2017). EVWMD could also consider treating the tertiary effluent for direct potable reuse (DPR) subject to the DPR regulations.

The Regional WRF has had a consistent seasonal flow and pattern from 2017 to 2021. Over the past five years, the Regional WRF produced a relatively consistent flow of approximately 6.1 mgd of RW with generally higher flows in the winter and slightly lower flows in the summer. Figure 3.20 shows the Regional WRF Production and uses from 2017 to 2021. Average monthly RW supply and demand are shown in Table 3.22. As shown on Figure 3.20 and in Table 3.22, RW use and discharge to the Temescal Creek do not have significant seasonal variation. Seasonal variation in RW discharged to Lake Elsinore is driven by seasonal variation in available RW. RW used internally at the Regional WRF accounts for 97 to 99 percent of the RW that is used and not discharged to Lake Elsinore or Temescal Creek. Outside irrigation demands account for less than 5 AFY of average annual demand.

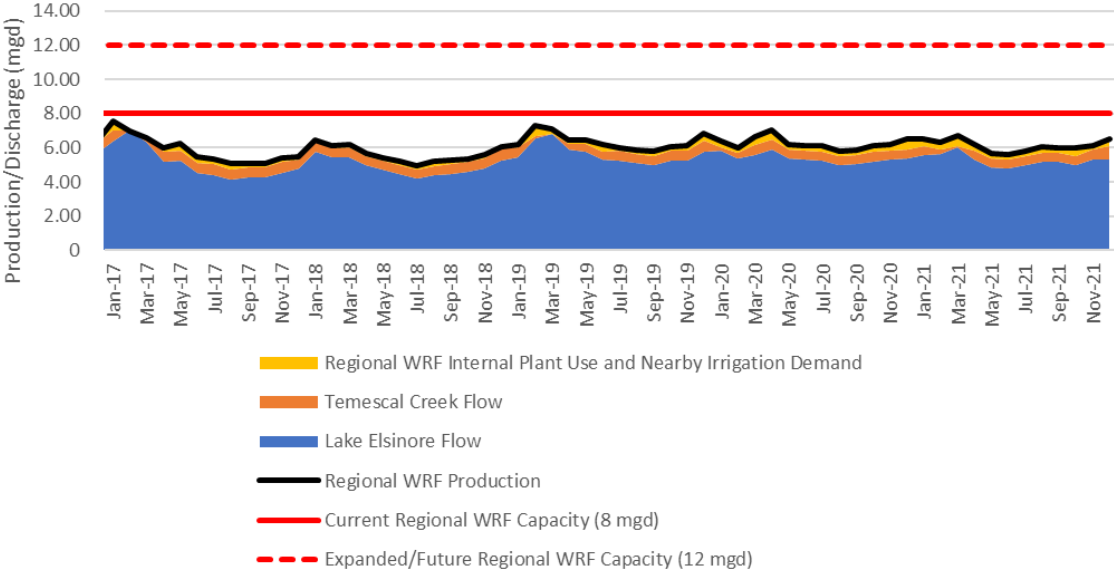

Figure 3.20 2017-2021 Regional WRF RW Production and Discharge

Table 3.22 2017-2021 Average Monthly Regional WRF RW Production and Discharge

Production and Discharge	Month (mgd)												Annual Average (mgd)
	January	February	March	April	May	June	July	August	September	October	November	December	
Production	6.63	6.63	6.64	6.28	6.01	5.71	5.63	5.59	5.59	5.72	5.88	6.28	6.05
Temescal Creek Discharge	0.51	0.26 ⁽¹⁾	0.29 ⁽¹⁾	0.51	0.52	0.53	0.56	0.56	0.56	0.57	0.60	0.63	0.51
Lake Elsinore Discharge	5.79	6.07	6.03	5.44	5.19	4.87	4.81	4.74	4.78	4.84	5.04	5.29	5.24

Notes:

(1) These values are lower than 0.5 mgd due to EMWD discharging their RW to Temescal Creek in the winter months. EVMWD has an agreement with the Regional Water Quality Control Board (RWQCB) that during the time of EMWD discharge to Temescal Creek, EVMWD can stop their flows to Temescal and divert all effluent discharge to Lake Elsinore.

3.5.3 Future Recycled Water Demand

As described above, the Regional WRF currently discharges all the RW to Lake Elsinore and to Temescal Creek and serves a few customers in the vicinity of the Regional WRF.

As population and water demands continue to increase within the EVMWD service area, influent flows will increase to the Regional WRF. On a rare basis, during winter months of wet years, excess water is released to Temescal Creek when the level in Lake Elsinore is higher than 1247 feet. The EVMWD SSMP includes a wastewater flow forecast for the Regional WRF influent flow as shown in Table 3.23. Wastewater flows are projected to increase from current levels (6 mgd) to around 13.9 mgd by year 2050 due to growth in the EVWMD service area portion that falls within the Regional WRF sewershed. The effluent from the Regional WRF will continue to be used for discharge to the Temescal Creek and Lake Elsinore, but the increasing surplus supply can be used for other RW purposes such as increased NPR, DPR, or IPR.

Table 3.23 Projected Regional WRF Influent Flow⁽¹⁾

Year	Flow (mgd)
2017-2021 Average	6.05
2025	7.99
2030	8.69
2035	10.07
2040	11.64
2045	13.10
2050	13.93

Notes:

(1) Reference: Carollo, 2023; SSMP.

An analysis of potential non-potable demand in areas surrounding the Regional WRF following the methodology described in Section 3.1.2 is shown in Table 3.24 with a total estimated demand of 1,826 AFY as shown on Figure 3.21.

Table 3.24 Regional Potential Non-Potable Expansion Customers

Customer Number	Customer/Planned Development Name	Potential Future Demand (AFY)	Potential Future Demand (mgd)	Existing Potable Customer or Planned Development
1	La Laguna RV Residential	175	0.156	Planned Development
2	Pacific Aggregates	109	0.097	Existing Potable Customer
3	The Cove Apartments	51	0.046	Planned Development
4	Hoist Industrial	17	0.015	Planned Development

Customer Number	Customer/Planned Development Name	Potential Future Demand (AFY)	Potential Future Demand (mgd)	Existing Potable Customer or Planned Development
5	Lakeside Pointe Apartments	17	0.015	Planned Development
6	Marriott Hotel	15	0.013	Planned Development
7	Walmart Shopping Center, Inc.	14	0.012	Planned Development
8	Highway 74 Contractor Yard	12	0.011	Planned Development
9	Nichols Industrial Center	12	0.011	Planned Development
10	Lakeview Manor	12	0.011	Planned Development
11	Riverside Drive Lake Front Hotel - Mixed Use	11	0.010	Planned Development
12	Ridgestone Apartments	10	0.009	Existing Potable Customer
13	California Ice Company	10	0.009	Existing Potable Customer
14	Grand Oaks Apartments	9	0.008	Existing Potable Customer
15	Lake Park	8	0.007	Existing Potable Customer
16	Shoreline Apartments	8	0.007	Existing Potable Customer
17	La Quinta Hotel on Dexter Avenue	7	0.006	Planned Development
18	Central Grocery and Retail	7	0.006	Planned Development
19	Sierra Vista Apartments	7	0.006	Existing Potable Customer
20	Collier Honda Dealership	6	0.005	Planned Development
21	Lakeside High School	6	0.005	Existing Potable Customer
22	Lake Elsinore Commercial	5	0.004	Planned Development
23	Elsinore Valley Cemetery	55 ¹	0.854	Existing user with private well
24	Alberhill Ranch Master Plan	341	0.304	Planned Development
Total		1,826	1.629	

Notes:

(1) The Elsinore Valley Cemetery is currently served by the Cemetery Well. This flow reflect historical pumping from the Cemetery Well as reported in the Elsinore Valley Subbasin Groundwater Sustainability Plan (Carollo, 2021).

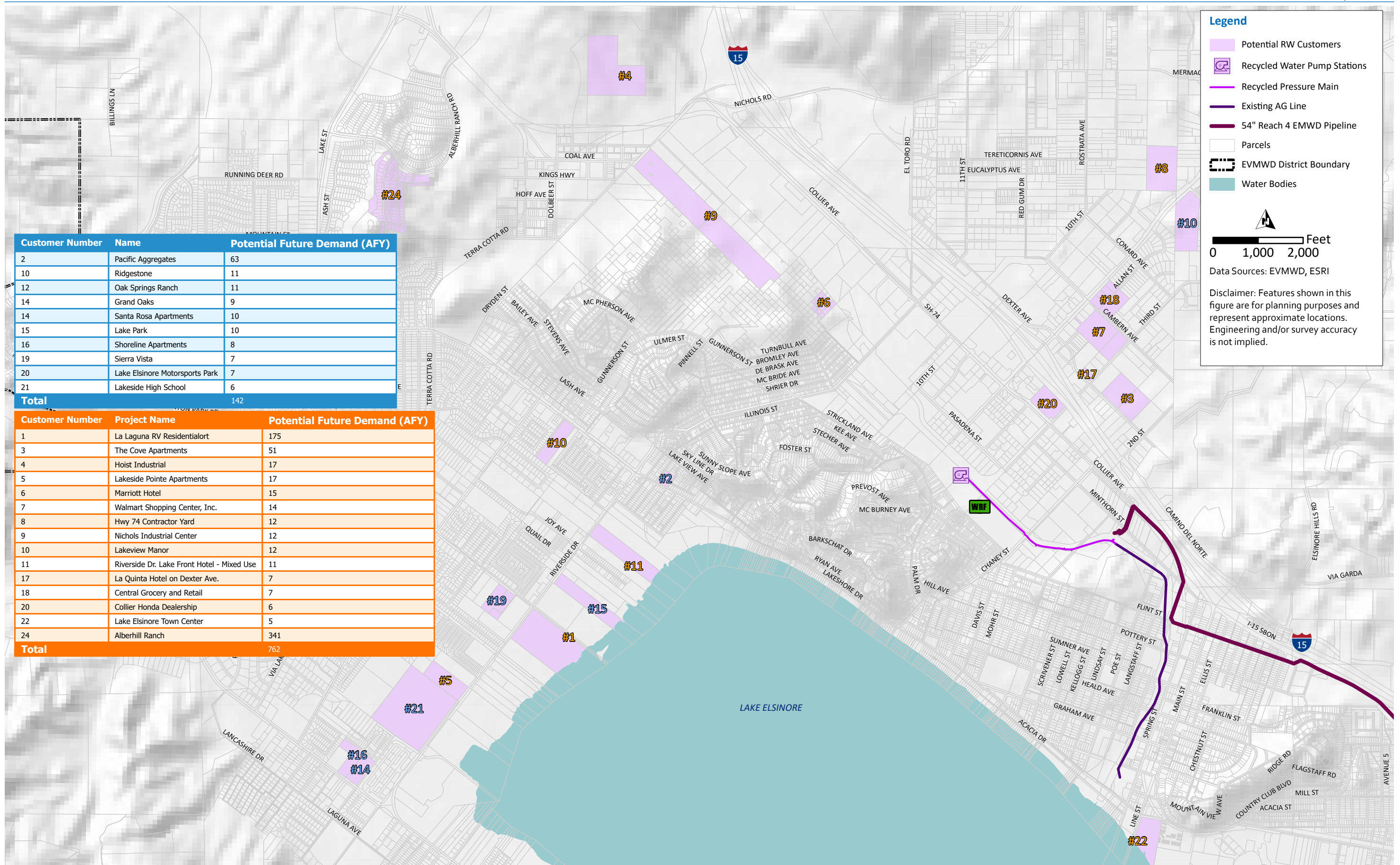

Customer Number	Name	Potential Future Demand (AFY)
2	Pacific Aggregates	63
10	Ridgestone	11
12	Oak Springs Ranch	11
14	Grand Oaks	9
14	Santa Rosa Apartments	10
15	Lake Park	10
16	Shoreline Apartments	8
19	Sierra Vista	7
20	Lake Elsinore Motorsports Park	7
21	Lakeside High School	6
Total		142

Customer Number	Project Name	Potential Future Demand (AFY)
1	La Laguna RV Residentialort	175
3	The Cove Apartments	51
4	Hoist Industrial	17
5	Lakeside Pointe Apartments	17
6	Marriott Hotel	15
7	Walmart Shopping Center, Inc.	14
8	Hwy 74 Contractor Yard	12
9	Nichols Industrial Center	12
10	Lakeview Manor	12
11	Riverside Dr. Lake Front Hotel - Mixed Use	11
17	La Quinta Hotel on Dexter Ave.	7
18	Central Grocery and Retail	7
20	Collier Honda Dealership	6
22	Lake Elsinore Town Center	5
24	Alberhill Ranch	341
Total		762

Figure 3.21 Future RW System Demand - Regional

-This Page Intentionally Left Blank-

As an alternative to an NPR system, IPR using groundwater augmentation at the Back Basin area or surface water augmentation at Canyon Lake is another possible RW use. IPR would increase water supply reliability, allowing EVMWD to reuse all their RW instead of wasting the RW during the winter months when demands are low. IPR provides benefits such as storing the advanced treated water from the Regional WRF, which a purple pipe system is incapable of doing. The advantage of groundwater augmentation is that it allows the District to save some water from wet years to dry years; surface water augmentation only allows for seasonal storage.

IPR provides additional benefit with water quality management in the basin including offset for salinity management. The District currently has a basin plan objective for total dissolved solids (TDS) not to exceed 480 mg/L. Many of the groundwater basins used by EVMWD have current TDS concentrations near or exceeding the TDS basin plan objective concentration. Using groundwater augmentation, the TDS of the groundwater will decrease since the water is advanced treated (e.g., reverse osmosis and advanced oxidation) and is assumed to have a TDS equal to 100 mg/L, which helps EVMWD meet a second goal of the Integrated Resources Plan (IRP) to improve water quality.

Furthermore, EVMWD has committed to perform the IPR project as part of the Basin Plan amendment to amend TDS and nitrate groundwater quality objectives for the Elsinore Groundwater Management Zone, which states that EVMWD will use RW from the Regional WRF for groundwater augmentation once flow requirements to Temescal Creek and Lake Elsinore are met (per the California RWQCB, Santa Ana Region, Resolution R8-2021-0044).

A further advantage of IPR is the ability to reuse the entire RW effluent relative to a purple pipe system where use is seasonal and often low during the winter months. A purple pipe system would require the discharge of seasonal winter excess flows to Temescal Creek representing a waste of EVMWD's water resource. Therefore, a purple pipe system may limit the full potential for RW reuse in the Regional area, while IPR allows for maximum reuse consistent with EVMWD's long-term water supply strategy.

For purposes of this RWSMP, it is assumed that the use of RW from the Regional WRF for IPR purposes has priority over other potential uses per a recently approved maximum benefit proposal by the RWQCB.

DPR would share many of the benefits of IPR but would not provide similar groundwater quality benefits. DPR regulations are not yet finalized, and this option has not been evaluated to the same extent as IPR for EVMWD.

3.5.4 Projected Supply and Demand Analysis

Figure 3.22 shows the projected wastewater flows to the Regional WRF, the long-term average committed uses, and flow available for RW use. As discussed above, 0.5 mgd of effluent must be discharged to Temescal Creek in all years (orange area). The historical annual average lake discharge of approximately 5.2 mgd (gray area) is expected to continue in all years in the future, with dry year effluent discharge to Lake Elsinore increasing until plant flow reaches 8 mgd (yellow area). Any remaining effluent above 7.5 mgd to Lake Elsinore and 0.5 mgd to Temescal Creek could be used for NPR, DPR, or IPR (blue). When the lake levels are below 1,240 ft-msl, all effluent up to 7.5 mgd needs to be discharged to the lake. In periods when the lake is above 1,240 ft-msl, all effluent except the 0.5 mgd for Temescal Creek would be available for IPR or DPR. In 2050, the amount of Regional WRF effluent available for IPR use is projected to be approximately 4,600 AFY, with an additional 4,200 AFY available in wet years when Lake Elsinore does not require additional replenishment. The NPR demand estimate of 528 AFY would only be able to put a fraction of this potential RW to beneficial use.

The 2017 *Indirect Potable Reuse Feasibility Study* recommending implementing Phase 1 of the IPR project by 2030. Updated analysis of projected flows shown on Figure 3.22 indicates that flow might be available for IPR or DPR starting in 2028, with sufficient water for an IPR project sometime after 2030. Revised sewer flows projections are lower than those used in the 2017 study due to decreasing per capita water consumption, which has been decreasing over the years due to water conservation efforts and state requirements to decrease water consumption due to ongoing drought conditions.

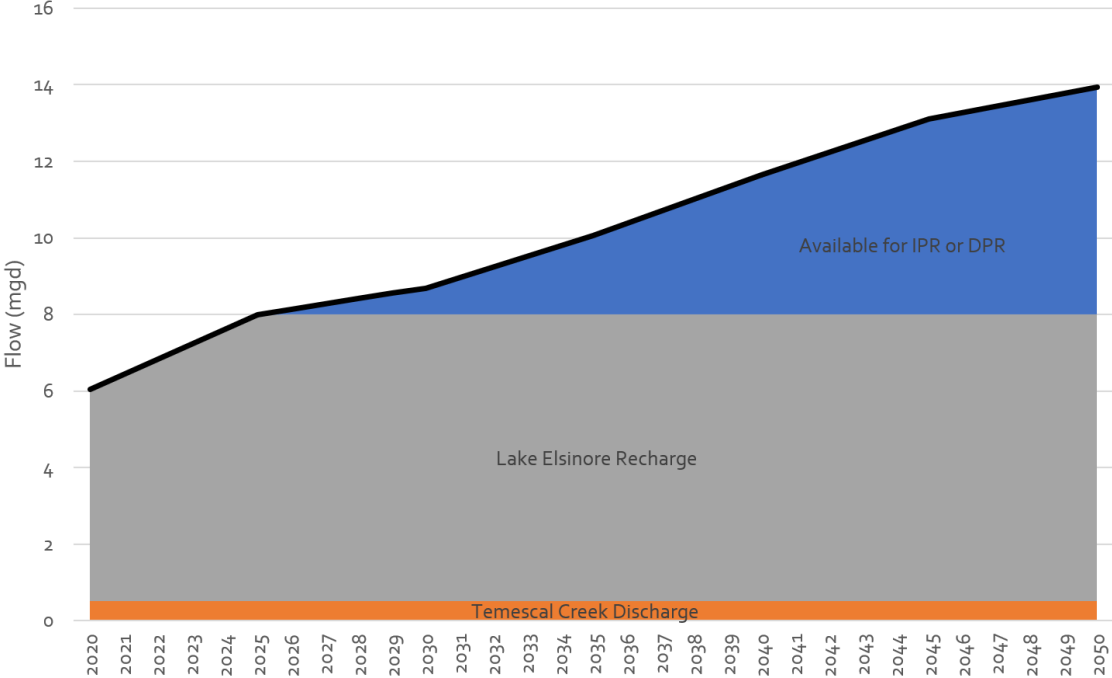

Figure 3.22 Projected Flows, Uses and Availability of Effluent at Regional WRF

-This Page Intentionally Left Blank-

Chapter 4

DESCRIPTION OF EXISTING SYSTEMS

4.1 Introduction

This chapter describes Elsinore Valley Municipal Water District's (EVMWD's) existing recycled water (RW) facilities and provides an understanding of the RW operations. Existing and potential RW customers, as well as a RW supply and demand balance, are discussed in Chapter 3 of this Recycled Water System Master Plan (RWSMP). Additionally, a hydraulic analysis of existing and future RW systems is discussed in Chapters 7 and 8 of this RWSMP, respectively.

EVMWD's existing RW services are divided into the following four systems:

- Wildomar.
- Railroad Canyon.
- Horsethief Canyon.
- Regional.

RW is served from four different water reclamation facilities (WRFs), three of which are owned and operated by EVMWD, Railroad Canyon WRF, Horsethief Canyon WRF, and Regional WRF. One system, Wildomar area, receives water primarily from the Temecula Valley Regional Water Reclamation Facility (TVRWRF), which is owned and operated by Eastern Municipal Water District (EMWD).

EVMWD's RW facilities include four active storage reservoirs (two tanks at Cottonwood, the wet well at Horsethief 2 Mid-Range Pump Station (MRPS) and Horsethief Canyon RW Reservoir), five booster pumping stations, and nearly 26 miles of pipeline. A summary of the RW components is presented in Table 4.1. The locations of the water facilities are shown on Figure 4.1.

Table 4.1 Summary of RW Distribution Components

Facility Type	Number
Storage Reservoirs (Not Including Ponds)	4
Booster Pump Stations	5
Pipeline (Miles) ⁽¹⁾	25.8

Notes:

(1) Source: EVMWD geographic information system (GIS) data.

4.2 Wildomar System

This section describes the RW system facilities in EVMWD's Wildomar system, which currently serves 57 RW service connections. The Wildomar RW system is shown on Figure 4.2.

4.2.1 Wildomar Sources of Supply

The volume of RW EVMWD receives in the Wildomar system is equal to the volume of wastewater generated in EVMWD's Southern Section, which is collected and treated at the Santa Rosa WRF owned by the Santa Rosa Regional Resources Authority (SRRRA), a Joint Powers Authority between EVMWD, EMWD, and Rancho California Water District (RCWD). The Santa Rosa WRF is operated by RCWD. The primary source of RW to the Wildomar system is the Temecula Valley Recycled Water Pipeline (TVRWP) effluent, which is conveyed through EMWD's 48-inch diameter pipeline from the EMWD's TVRWRF. There is a connection from Santa Rosa WRF into the TVRWP to add supplemental RW if needed, but it is typically not used for providing RW to EVMWD. RCWD treats all the EVMWD's southern area wastewater sent to the Santa Rosa WRF. The 2009 three-party Agreement and later revision of this agreement shows the exchange of RW among the 3-agencies (EMWD, RCWD and EVMWD) and capacities purchased in the EMWD's 48-inch diameter RW delivery line. The 48-inch diameter TVRWP connects the TVRWRF to EMWD's existing 54-inch diameter Reach 4 pipeline and can back feed water from EMWD's other WRFs if available.

EVMWD's RW supply allocation is set at the beginning of each fiscal year based on EVMWD's actual average daily wastewater flow contribution to the Santa Rosa WRF during the previous fiscal year. This supply allocation is calculated based on monthly usage, limiting the amount of flow EVMWD is able to receive each month. If EVMWD does not use its equal allocation of RW, then it is forfeited to EMWD. Additionally, EVMWD may also purchase additional RW from EMWD on an as-available basis. There is also a maximum capacity of 2.0 million gallons per day (mgd) of peak instantaneous supply permitted from the TVRWP based on an amended agreement between EVMWD and EMWD dated October 13, 2016. The 2.0 mgd of peak instantaneous supply is sufficient to meet Wildomar system existing peak hour demands (PHDs).

4.2.2 Wildomar Demands

Total demands for the Wildomar system's 57 service connections were 523 acre-feet per year (AFY) in the year 2021.

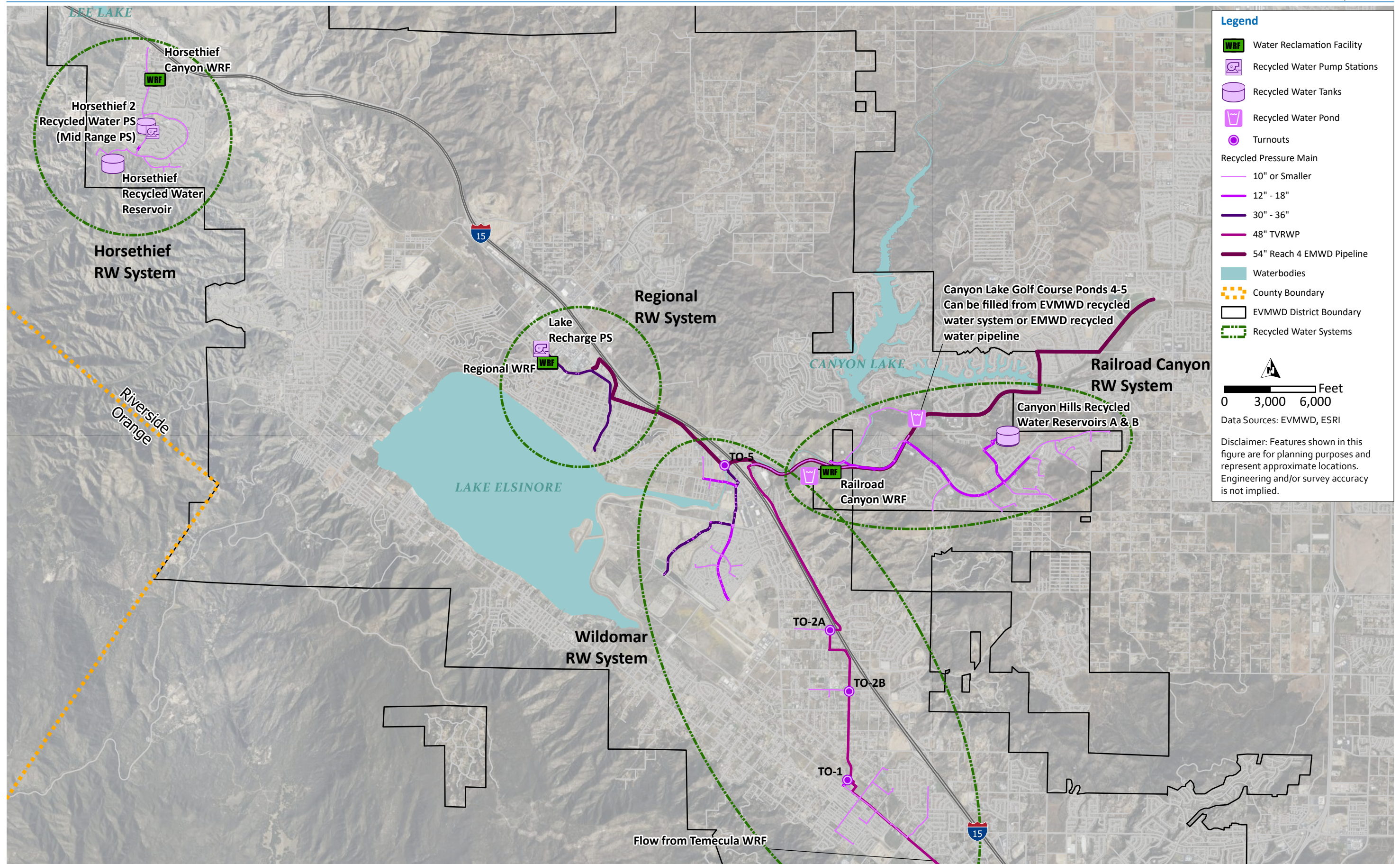

Legend

- Water Reclamation Facility
- Recycled Water Pump Stations
- Recycled Water Tanks
- Recycled Water Pond
- Turnouts
- Recycled Pressure Main**
 - 10" or Smaller
 - 12" - 18"
 - 30" - 36"
 - 48" TVRWP
 - 54" Reach 4 EMWD Pipeline
- Waterbodies
- County Boundary
- EVMWD District Boundary
- Recycled Water Systems

0 3,000 6,000 Feet

Data Sources: EVMWD, ESRI

Disclaimer: Features shown in this figure are for planning purposes and represent approximate locations. Engineering and/or survey accuracy is not implied.

Figure 4.1 RW System Overview

-This Page Intentionally Left Blank-

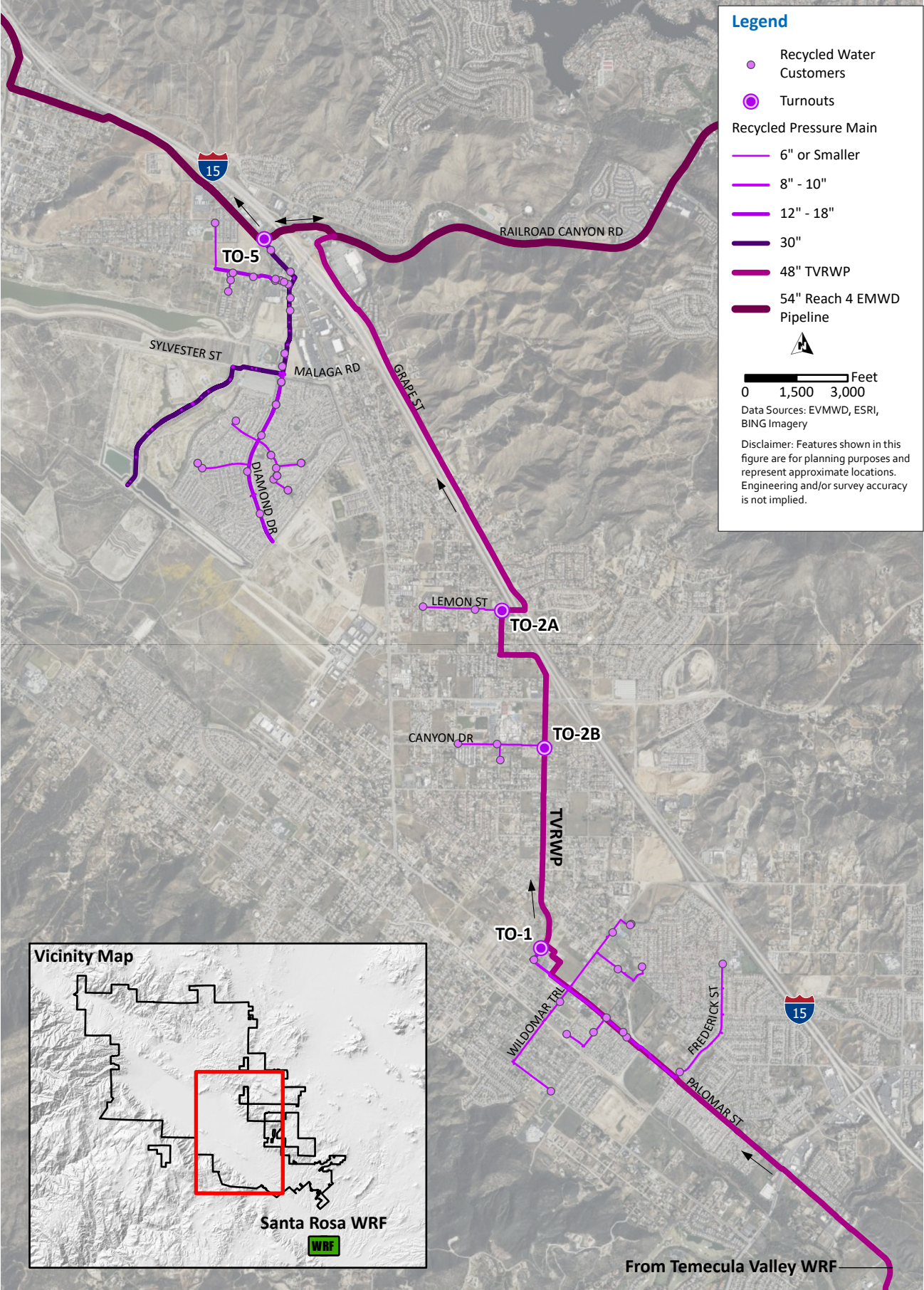

Figure 4.2 Wildomar RW System

-This Page Intentionally Left Blank-

4.2.3 Wildomar Turnouts

The RW is supplied to four turnouts (Turnout Nos. 1, 2A, 2B, and 5) owned and operated by EVMWD in the Wildomar area. Three turnouts (Turnout Nos. 1, 2A, and 2B) are located along the 48-inch diameter TVRWP, while Turnout No. 5 is located on the 54-inch diameter Reach 4 pipeline. The four turnouts serve 57 service connections in the Wildomar system.

The initial Wildomar Phase 1 design included Turnout Nos. 2, 3 and 4, but before design and construction was complete, some customers changed and final design and construction included only Turnout Nos. 1, 2A, 2B and 5. Turnout Nos. 3 and 4 do not exist.

4.2.4 Wildomar Distribution Network

EVMWD's Wildomar RW distribution system network consists of approximately 10.6 miles of pipeline, which range in diameter from 1 inch to 30 inches. The distribution of pipeline length by diameter and installation period is summarized in Table 4.2. Figure 4.2 shows the pipelines colored by diameter range. It should be noted that the year of installation is unknown for about 10 percent of the system length.

Table 4.2 Wildomar Pipe Length by Diameter and Age

Diameter (Inches)	Pipeline Length (Feet) by Installation Year									Total Length (Feet)
	2006	2007	2011	2012	2013	2015	2016	2017	Unknown	
1	0	0	558	0	0	25	15	43	152	794
2	85	0	0	0	41		188	75	0	389
4	2,924	0	0	0	814	938	1,768	0	714	7,158
6	15	227	17,942	787	0	0	0	0	3,010	21,982
8	30	24	5,306	0	0	0	0	0	0	5,360
12	2,207	12	3,250	58	0	0	1,637	1,437	0	8,601
16	0	5	0	0	0	0	0	0	0	5
18	0	0	0	146	0	0	0	0	0	146
30	0	5,548	0	5,247	0	0	0	0	0	10,796
Unknown	0	0	26	190	0	0	0	0	766	982
Total (Feet)	5,261	5,817	27,083	6,428	855	963	3,608	1,555	4,643	56,213
Total (Miles)	1.0	1.1	5.1	1.2	0.2	0.2	0.7	0.3	0.9	10.6

4.2.5 Wildomar Operations

A hydraulic schematic of the Wildomar system is shown on Figure 4.3. The four Wildomar system turnouts are served directly from the TVRWP.

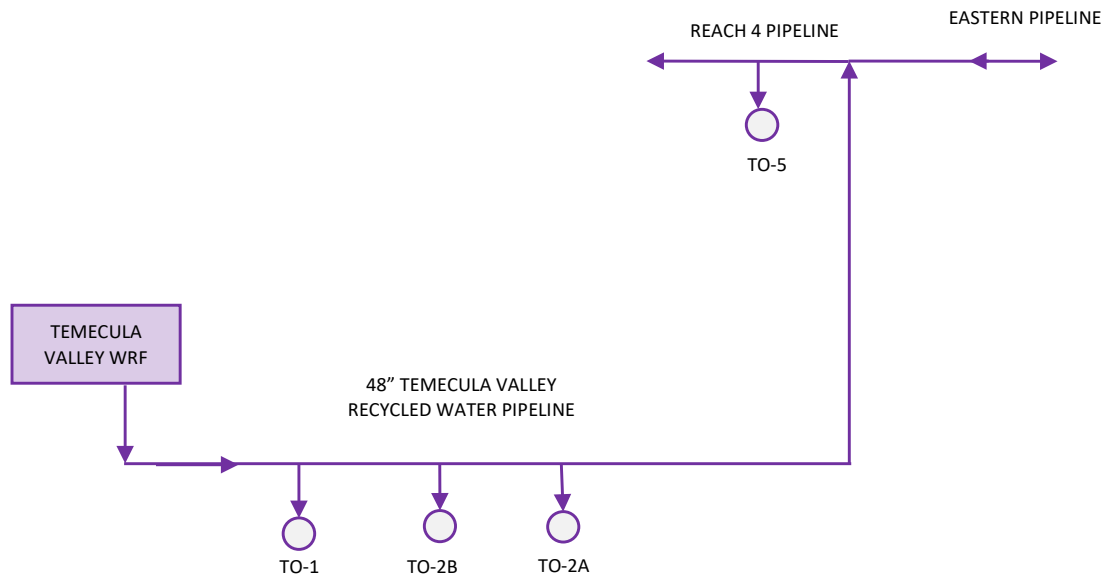

Figure 4.3 Wildomar System Schematic

The customers in the Wildomar system have ground elevations range from 1,219 feet to 1,347 feet, and system pressure in the distribution system range from 74 pounds per square inch (psi) to 152 psi.

There are neither pump stations nor storage facilities in the Wildomar system.

4.3 Railroad Canyon System

This section describes the RW system facilities in EVMWD's Railroad Canyon system, which currently serves 58 RW connections. The Railroad Canyon RW system is shown on Figure 4.4.

4.3.1 Railroad Canyon Sources of Supply

The Railroad Canyon WRF is a scalping plant, which receives wastewater from Tuscany Hills, Canyon Lake, and Cottonwood areas, producing Title 22 tertiary-treated RW. As Railroad Canyon WRF has no disposal or solids-handling facilities, all wastewater from the upstream sewersheds that is not needed for RW bypasses Railroad Canyon WRF and is sent to the Regional WRF for further processing. Railroad Canyon WRF has an average daily flow capacity of 1.12 mgd and two on-site RW storage ponds. The third on-site pond is unlined and used for stormwater purposes only at this time. Excess RW during low or no demand periods can also be discharged into the sewer for treatment at the Regional WRF.

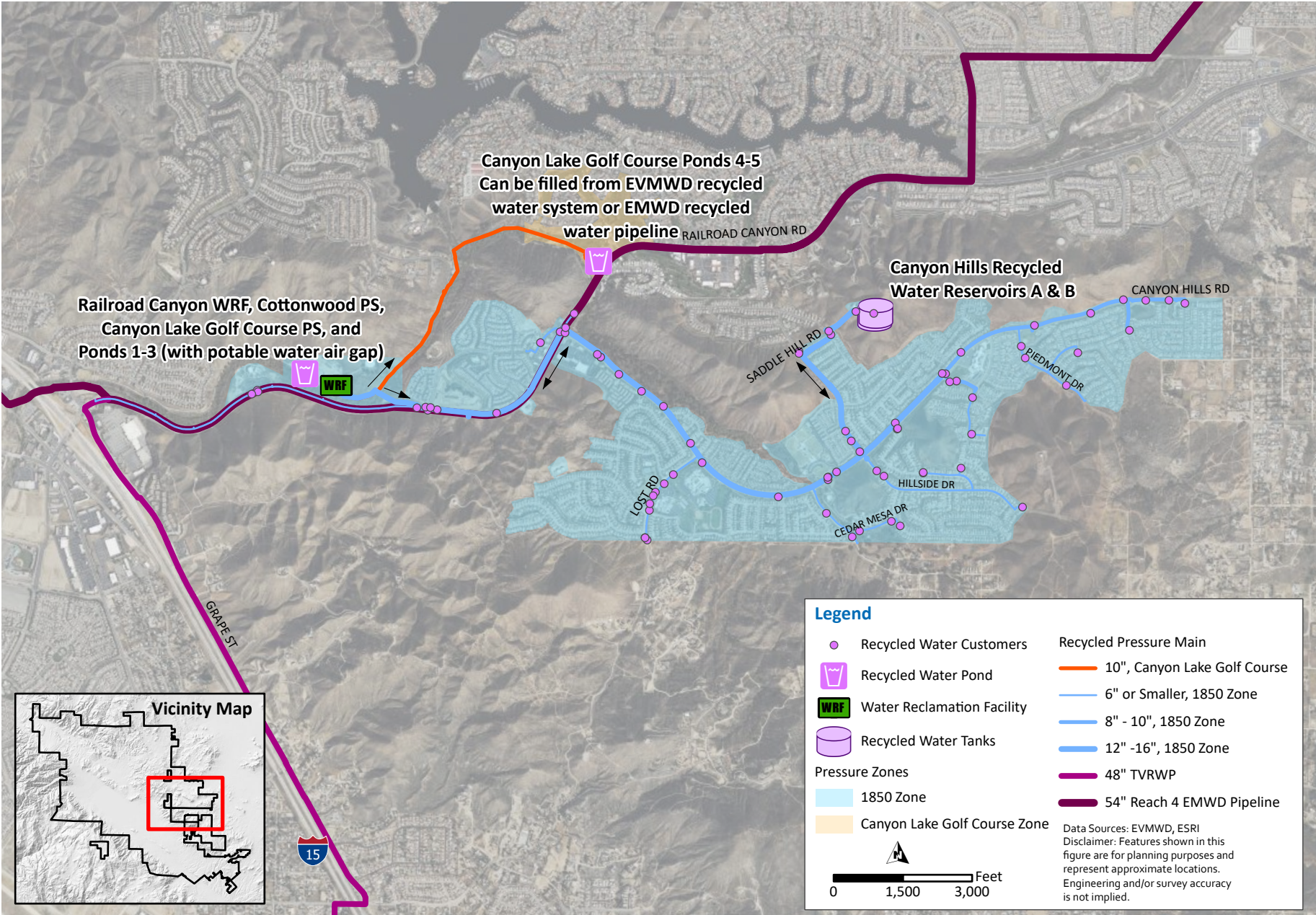

Figure 4.4 Railroad Canyon RW System

-This Page Intentionally Left Blank-

The Railroad Canyon area can also receive RW purchased from EMWD and delivered via the Reach 4 pipeline based on an amended agreement between EVMWD and EMWD dated June 25, 2020. The Reach 4 pipeline delivers water produced at EMWD's Moreno Valley, Perris Valley, San Jacinto Valley, and Sun City Regional WRFs. EMWD RW sales to EVMWD in the Railroad Canyon service area are limited to 329 AFY with a maximum flow rate of 200 gallons per minute (gpm), although additional RW can be requested by EVMWD and authorized by EMWD, if available.

If additional RW is needed in the Railroad Canyon system beyond what can be produced at Railroad Canyon WRF and purchased from EMWD, EVMWD can augment RW supplies by filling Pond Nos. 1 and 2 at Railroad Canyon WRF with potable water supplement. This process of providing supplemental potable water occurs when the levels at Pond Nos. 1 and 2 are low, and typically occurs during summer months when RW demands are high.

4.3.2 Railroad Canyon Demands

Total demands for the Railroad Canyon system's 58 RW connections were 656 AFY in year 2021. In 2021, total of 156 AFY was purchased from EMWD and 38 AFY of supplemental potable water was used.

4.3.3 Railroad Canyon Pump Stations

The Railroad Canyon WRF has five on-site RW pumps at two pump stations to distribute RW to its service area. Three pumps are identified as Cottonwood Hills Reclaimed Water Pumps and are used to distribute the RW into the 1850 Pressure Zone and fill the two Canyon Hills RW reservoirs. Two pumps are identified as the Railroad Canyon WRF Canyon Lake Golf Course (CLGC) Ponds Pump Station and are used to deliver water to Pond Nos. 4 and 5 located near the CLGC). RW is pumped from Pond Nos. 4 and 5 for landscape irrigation for the CLGC and the City of Canyon Lake customers. Upon request by EVMWD and availability at EMWD, RW can also be discharged into Pond Nos. 4 and 5 from the EMWD connection adjoining the ponds. The pump stations taking pumping RW out of Pond Nos. 4 and 5 for the golf course and the City of Canyon Lake customers are owned and operated by the CLGC and the City of Canyon Lake, respectively.

Characteristics of the Cottonwood Hills Recycled Water Pump Station (RWPS) and the CLGC Ponds Pump Station pumps are summarized in Table 4.3.

Table 4.3 Railroad Canyon Pumps

Pump Name	Design Flow (gpm) ⁽¹⁾	Design Head (Feet) ⁽¹⁾	Horsepower	Pumping From	Pumping To	Year Installed
Cottonwood Hills Pump 1	400	516	75	Railroad Canyon WRF	1850 Pressure Zone	2002
Cottonwood Hills Pump 2	400	516	75	Railroad Canyon WRF	1850 Pressure Zone	2002
Cottonwood Hills Pump 3	400	516	75	Railroad Canyon WRF	1850 Pressure Zone	2002
Railroad Canyon WRF-CLGCP-Pump Station Golf Course Pump 1	733	171	38.5	Railroad Canyon WRF	CLGC and City of Canyon Lake	1985
Railroad Canyon WRF-CLGCP-Pump Station Golf Course Pump 2	733	171	38.5	Railroad Canyon WRF	CLGC and City of Canyon Lake	1985

Notes:

(1) Source: Pump curves provided by EVMWD.

4.3.4 Railroad Canyon Storage

There are two on-site RW storage ponds at Railroad Canyon WRF which equalize flow between the RW production at Railroad Canyon WRF and the distribution pump station. The two storage ponds are 1.57 million gallons (MG) each and have a combined capacity of 3.14 MG. Pond Nos. 1 and 2 are lined, while Pond No 3 is not lined. Pond No 3 has a capacity of 0.78 MG but is currently used only for stormwater purposes.

In addition, there are two off-site RW storage ponds adjoining CLGC. Pond Nos. 4 and 5 are used to store water for the CLGC and the City of Canyon Lake. These two ponds have a combined capacity of 3.12 MG.

The Canyon Hills RW 1850 A and 1850 B Tanks provide storage for the 1850 Pressure Zone and have a total capacity of 2.6 MG. The RW tanks are in the northern portion of the Railroad Canyon service area at Desert Rose Way. The CLGC Pond Nos. 4 and 5 containing RW are adjacent to each other and are located south of the CLGC on

Railroad Canyon Road. The ponds are modeled as one reservoir in the hydraulic model. The characteristics of the reservoirs are summarized in Table 4.4.

Table 4.4 Railroad Canyon Reservoirs and Storage Ponds

Name	Volume (MG)	Pressure Zone Served	Diameter (Feet)	Height (Feet)	Bottom Elevation (Feet)	Overflow Elevation (Feet)	Year Installed
Railroad Canyon WRF Pond No. 1	1.57	None	N/A	8	1,314	1,322	1992
Railroad Canyon WRF Pond No. 2	1.57	None	N/A	8	1,314	1,322	1992
Railroad Canyon WRF Pond No. 3 ⁽¹⁾	0.78	None	N/A	8	1,314	1,322	1992
CLGC Pond No. 4	2.0	None	N/A	10	1,381	1,391	1985
CLGC Pond No. 5	1.12	None	N/A	10	1,381	1,391	2003
Canyon Hills RW Tank 1850 A	1.3	1850	70	23	1,827	1,850	2003
Canyon Hills RW Tank 1850 B	1.3	1850	70	23	1,827	1,850	2003

Notes:

(1) Pond No. 3 is not used for RW storage but is currently used only for stormwater purposes.

4.3.5 Railroad Canyon Distribution Network

EVMWD's Railroad Canyon RW distribution system network consists of approximately 9.58 miles of pipeline, which range in diameter from 1 to 24 inches. The distribution of pipeline length by diameter and installation period has been summarized in Table 4.5, and Figure 4.4 shows the pipelines colored by diameter.

Table 4.5 Railroad Canyon Pipe Length by Diameter

Diameter (Inches)	Pipeline Length (Feet) by Installation Year															Total Length (Feet)
	1985	2002	2003	2004	2005	2006	2007	2008	2010	2011	2013	2014	2015	2016	Unknown	
1		16		189	93	40	30	38			78		87		9	581
2		54			15						15					247
4		60											18			227
6		2,372		2,953	211	122	6,328	281			2,265	2,262	109		71	24,892
8						2,163				762	612		3,813			7,350
10	7,863													76	738	8,677
12		5,096	512	2,043	4,711	2,497	24								62	14,946
14																3,016
16							721		552							4,530
24															187	187
Unknown		11			120										327	458
Total (Feet)	7,863	7,609	512	5,185	5,150	4,823	7,103	319	552	762	2,970	2,262	4,027	76	1,394	50,607
Total (Miles)	1.5	1.4	0.1	1.0	1.0	0.9	1.3	0.1	0.1	0.1	0.6	0.4	0.8	0.0	0.3	9.58

4.3.6 Railroad Canyon Pressure Zones

There are two pressure zones in the Railroad Canyon system. One pipeline serves only Pond Nos. 4 and 5, which serve the CLGC. The other pressure zone is the Cottonwood Pressure Zone, with a nominal hydraulic grade of 1,850 feet. Customers in the Cottonwood Pressure Zone have ground elevations range from 1,312 feet to 1,829 feet, and system pressure in the distribution system range from 53 psi to 242 psi.

4.3.7 Railroad Canyon Operations

A hydraulic schematic of the Railroad Canyon system is shown on Figure 4.5.

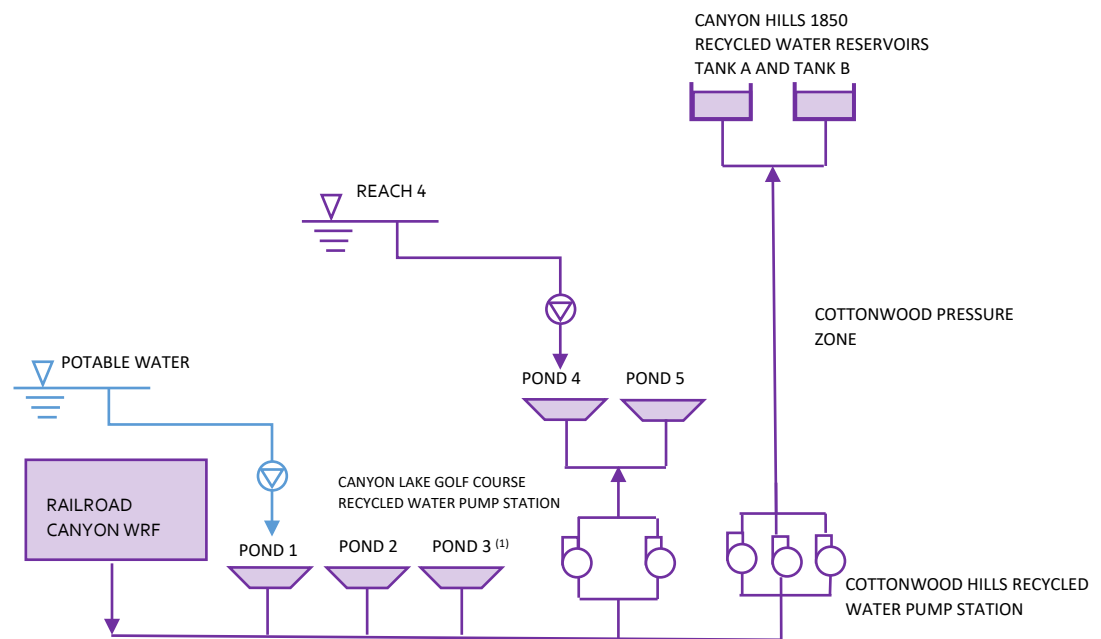

(1) Pond No. 3 is not used for RW storage but is currently used only for stormwater purposes.

Figure 4.5 Railroad Canyon System Schematic

EVMWD operations staff determine how much RW they expect will be needed based on historical usage, up to the capacity of the Railroad Canyon WRF. This amount of wastewater is treated at Railroad Canyon WRF and stored at the storage ponds on-site (Pond Nos. 1 and 2). The remainder of the wastewater in the sewer bypasses the Railroad Canyon WRF, and waste activated sludge solids from the treatment process, are discharged to the sewer for treatment at the Regional WRF.

RW is pumped from the on-site storage Pond Nos. 1 and 2 at Railroad Canyon WRF through the two pump stations, to the CLGC and to the Cottonwood system. The unlined Pond 3 is currently not used to store RW. During wet weather, the on-site storm water runoff can be directed to this pond, or to the stormwater discharge point. RW to the Cottonwood system is either stored in the two 1850 Zone reservoirs

or delivered directly to customers. All water to the CLGC is stored in Pond Nos. 4 and 5. CLGC and the City of Canyon Lake pump from Pond Nos. 4 and 5 using their own equipment.

When levels drop in Pond Nos. 4 and 5 and there is insufficient RW available from Railroad Canyon WRF, EVMWD purchases water from EMWD through the connection at Pond Nos. 4 and 5 to provide supplemental water to CGLC. If there are still insufficient RW supplies, then EVMWD transfers potable water to Pond Nos. 1 and 2 through an air gap as make-up water.

4.4 Horsethief System

This section describes the RW system facilities in EVMWD's Horsethief system, which currently serves 35 RW customers. The Horsethief RW system is shown on Figure 4.6.

4.4.1 Horsethief Source of Supply

The Horsethief Canyon WRF has a capacity of 0.5 mgd and serves the Horsethief service area. Currently, the Horsethief Canyon WRF is in process of being expanded to a total capacity of 0.8 mgd and upgraded with denitrification, membrane bioreactors (MBR), and sludge dewatering processes, producing Title 22 tertiary-treated RW. RW produced at the Horsethief Canyon WRF is stored in lined storage pond on-site. The second unlined pond is currently not being used for typical storage activities.

After the plant expansion to 0.8 mgd, in the next 2 to 3 years, there is a plan to convert the current secondary effluent equalization pond into another RW storage pond. After completion of that project, there will be two on-site RW storage ponds. With the new MBR process, there would be no need for secondary effluent equalization.

Historically, Barney Lee Well has been used as supplemental water to the RW system, filling the RW storage ponds at Horsethief Canyon WRF. Barney Lee Well is no longer in service and not expected to be used as a supplement to the RW system in the future. There is a potable water supplement option available at the MRPS wet well if additional supplies are needed.

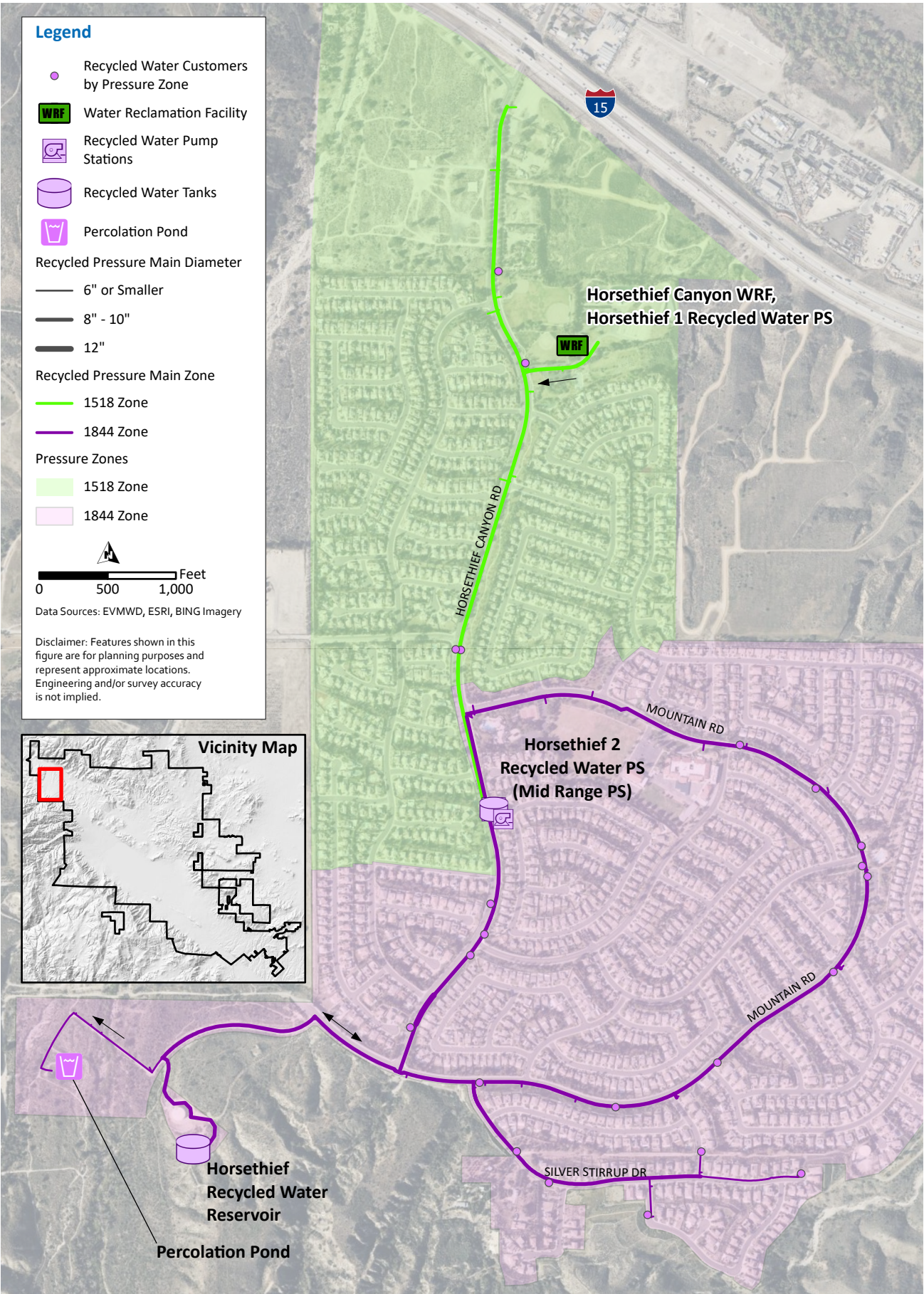

Figure 4.6 Horsethief RW System

-This Page Intentionally Left Blank-

4.4.2 Horsethief Demands

Total demands for the Horsethief system's 45 service connections were 443 AFY in the year 2021.

4.4.3 Horsethief Pump Stations

The Horsethief Canyon WRF has two on-site pumps at the Horsethief 1 RWPS to distribute RW into the 1518 Pressure Zone and to the MRPS. The Horsethief 2 RWPS, also known as the MRPS has three pumps and serves to pump RW from the 1518 Pressure Zone to the 1844 Pressure Zone. All the water produced at Horsethief Canyon WRF is pumped through Horsethief 1 RWPS and through the MRPS for disposal at the Percolation Pond if it is not delivered to the customers. Table 4.6 summarizes the pumping characteristics for all pumps in the Horsethief service area.

Table 4.6 Horsethief Canyon Booster Pumps (at Horsethief Canyon WRF and the MRPS)

Pump Name	Design Flow (gpm)	Design Head (Feet)	Pumping From	Pumping To	Year Installed
Horsethief 1 Pump 1 (at Horsethief Canyon WRF)	334	200	Horsethief WRF	1518 Pressure Zone	2003
Horsethief 1 Pump 2 (at Horsethief Canyon WRF)	334	200	Horsethief WRF	1518 Pressure Zone	2003
Horsethief 2 Pump 1 (MRPS)	334	350	1518 Pressure Zone	1844 Pressure Zone	1995
Horsethief 2 Pump 2 (MRPS)	334	350	1518 Pressure Zone	1844 Pressure Zone	1995
Horsethief 2 Pump 3 (MRPS)	334	350	1518 Pressure Zone	1844 Pressure Zone	1995

4.4.4 Horsethief Canyon Storage

The ponds at the Horsethief Canyon WRF provide pumped storage for the 1518 Pressure Zone. There is also a small amount of gravity storage for the 1518 Pressure Zone in the wet well at the MRPS. The Horsethief RW Zone 2 Tank provides gravity storage for the 1844 Pressure Zone. Table 4.7 summarizes the characteristics of Horsethief RW storage.

Table 4.7 Horsethief Canyon Storage and Excess Wet Weather Discharge

Name	Volume (MG)	Pressure Zone Served	Diameter (Feet)	Height (Feet)	Bottom Elevation (Feet)	Overflow Elevation (Feet)	Year Installed
Horsethief Canyon WRF Ponds ⁽¹⁾	0.92	None	N/A	3	1,297	1,300	1995
Horsethief 2 (MRPS) Wet Well	0.05	1518	N/A	20	1,498	1,518	1995
Horsethief Canyon RW Reservoir	0.17	1844	35	24	1,820.5	1,844	1995
Horsethief Canyon Percolation Pond	1.50	1844 (disposal only)	N/A	8	1,714	1,722	1991

Notes:

(1) One pond has a capacity of 0.50 MG; the second pond has a capacity of 0.42 MG.

4.4.5 Horsethief Canyon Distribution Network

EVMWD's Horsethief RW distribution network consists of approximately 4.9 miles of pipeline, which range in diameter from one inch to 12 inches. The distribution of pipeline length by diameter and installation period is summarized in Table 4.8, while Figure 4.6 shows the pipelines colored by diameter range. As shown in Table 4.8, a vast majority (84 percent) of the RW system consists of 8-inch and 10-inch diameter pipes.

Table 4.8 Horsethief Canyon RW Pipe Length by Diameter and Age

Diameter (Inches)	Pipeline Length (Feet) by Installation Year					Total Length (Feet)
	1992	1995	1999	2015	Unknown	
1	47			76	24	147
2	17	84	28	30		159
4		661	75	15	29	780
6	1,401	119		1,237		2,758
8		6,297	2,914	2,052	935	12,198
10		9,382				9,382
12		250				250
Total (Feet)	1,466	16,793	3,017	3,411	988	25,675
Total (Miles)	0.3	3.2	0.6	0.6	0.2	4.9

Any water that is not used by RW customers is disposed of at the percolation pond. This is the only alternative to dispose of excess RW during low demand periods from Horsethief WRF. This percolation pond is located in the 1844 Zone. When levels in the Horsethief 1844 Zone Reservoir are above the overflow, flows overflow into the percolation pond. The percolation pond's characteristics are in Table 4.7.

4.4.6 Horsethief Pressure Zones

There are two pressure zones in the Horsethief system, at nominal hydraulic grades of 1,518 and 1,844 feet. Customers in the 1518 Pressure Zone have ground elevations ranging from 1,255 feet to 1,341 feet, and system pressure in the distribution system range from 75 to 112 psi. Customers in the 1844 Pressure Zone have ground elevations ranging from 1,458 feet to 1,745 feet, and system pressure in the distribution system range from 44 to 172 psi.

4.4.7 Horsethief Operations

A hydraulic schematic of the Horsethief system is shown on Figure 4.7.

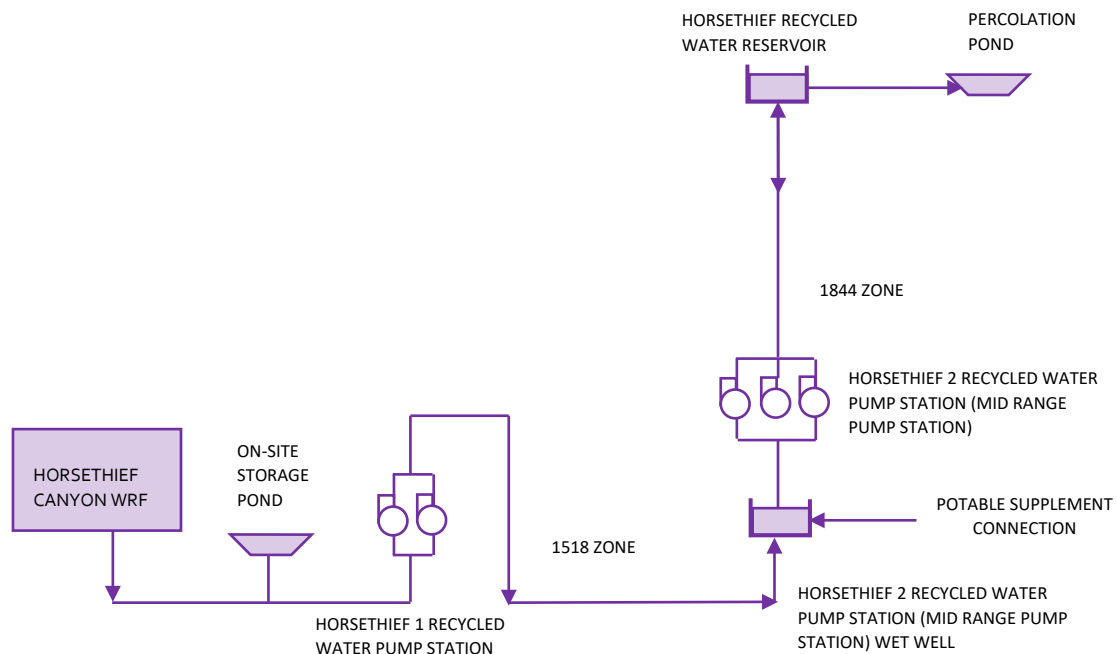

Figure 4.7 Horsethief System Schematic

Water produced at Horsethief Canyon WRF is stored in the one lined pond on-site, which is also needed as operational storage for the 1518 Pressure Zone. All the water produced at the Horsethief Canyon WRF is pumped to the 1518 Pressure Zone at the Horsethief 1 RWPS located on-site at the Horsethief Canyon WRF. The pumps are controlled by the level in the sump at the MRPS. Water is pumped at the MRPS to the 1844 Pressure Zone and the Horsethief RW reservoir. When the Horsethief RW reservoir is full, excess RW is sent to the Horsethief Canyon Percolation Pond located near the Horsethief RW reservoir. This is the method to dispose of excess RW during low demand periods.

4.5 Regional System

This section describes the RW system facilities in EVMWD's Regional system, which currently serves only EVMWD itself through four service meters. The Regional RW system is shown on Figure 4.8.

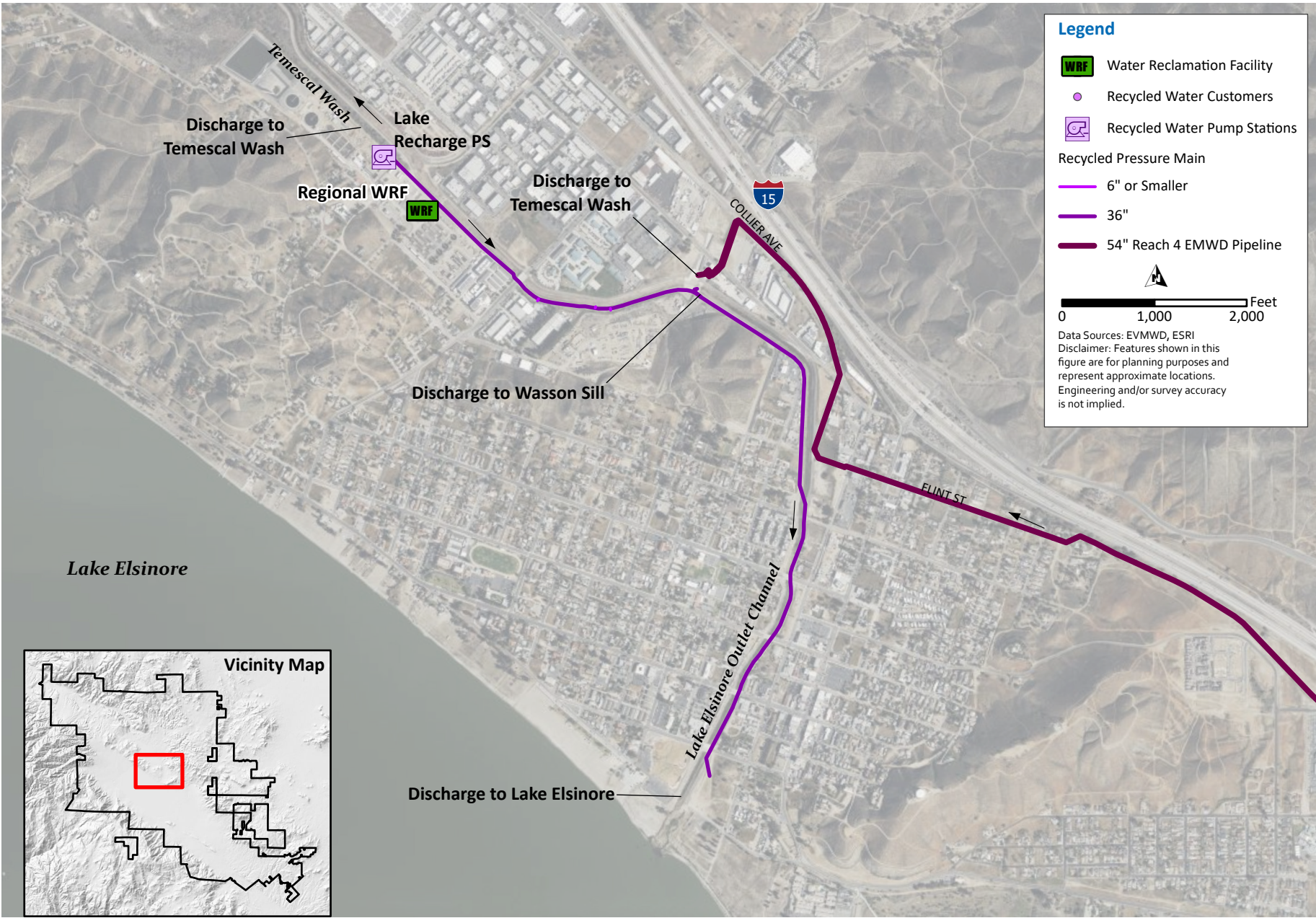

Figure 4.8 Regional RW System

-This Page Intentionally Left Blank-

4.5.1 Regional Source of Supply

The Regional WRF produces Title 22 tertiary-treated RW and has a nominal design capacity of 8 mgd (average daily flow), with a planned expansion to 12 mgd (average daily flow).

4.5.2 Regional Demands

The 0.5 mgd of effluent produced by the Regional WRF is discharged to Temescal Creek to maintain the downstream riparian habitat as required by EVMWD's permit for the Regional WRF with the Regional Water Quality Control Board (RWQCB) Order No. R8-2013-0017.

The remaining plant flow is typically discharged to Lake Elsinore to maintain the lake levels for recreational purposes based on an agreement between EVMWD and the City of Lake Elsinore.

The only other RW use from the Regional system is for irrigation use around the EVMWD office building and parking lots and parts of Regional WRF's landscaping.

4.5.3 Regional Distribution Network

RW from Regional WRF will continue to be discharged to Temescal Creek and to Lake Elsinore. Figure 4.8 presents the Regional System service area, while Table 4.9 presents the RW distribution system by pipeline diameter and year of installation. The flow to Temescal Creek is via gravity. The 36-inch pipe from the plant to the Wasson Sill is a force main. From the Wasson Sill, effluent can be discharged by gravity to Lake Elsinore via the flood control channel, or through the recently converted part of the agricultural pipeline which has an outfall structure located on the edge of Lake Elsinore. EVMWD preference is to use this new constructed pipeline due to the added benefits such as sending more water to the Lake by avoiding losses through the channel infiltration.

The remainder of the water is discharged to Lake Elsinore through the Lake Recharge Pump Station at the Regional WRF through a force main. The water historically has been discharged at Wasson Sill, to be conveyed through the Lake Elsinore Outlet Channel. In 2019, EVMWD converted an existing 36-inch diameter agricultural pipeline to convey RW by gravity from Wasson Sill to Lake Elsinore; use of this agricultural pipeline reduces water loss due to evaporation and infiltration and maximizes the amount of water delivered from Regional WRF to Lake Elsinore.

As seen in Table 4.9, a majority of the pipe is 36-inch diameter, both the force main from the Lake Recharge Pump Station and the agricultural pipeline converted to RW.

Table 4.9 Regional Pipe Length by Diameter

Diameter (Inches)	Pipeline Length (Feet) by Installation Year		Total Length (Feet)
	2005-2014	Unknown	
Unknown	-	78	78
6	58	-	58
36	4,220	-	4,220
Total (Feet)	4,278	78	4,356
Total (Miles)	0.8	0.0	0.80

4.5.4 Regional Operations

A hydraulic schematic of the Regional System is shown on Figure 4.9.

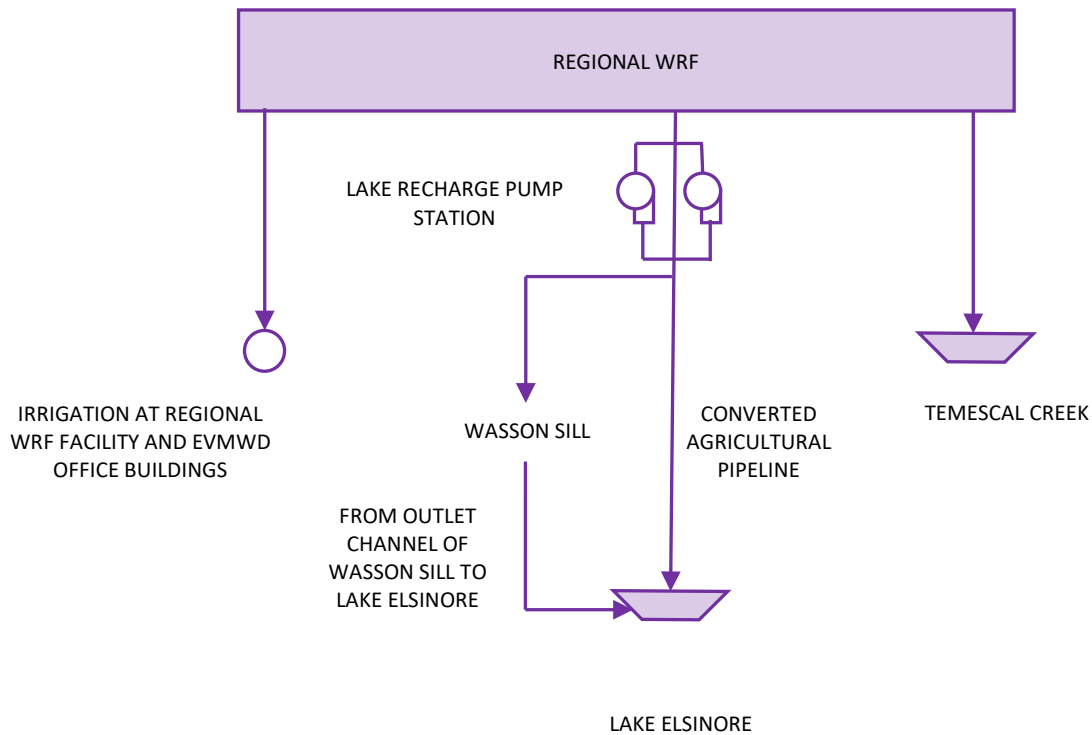

Figure 4.9 Regional System Schematic

RW for use at EVMWD's office is fed from the utility water system at the Regional WRF.

Chapter 5

RECYCLED WATER SYSTEM MODEL DEVELOPMENT

5.1 Introduction

This section describes the processes utilized to update the hydraulic model of Elsinore Valley Municipal Water District's (EVMWD's) recycled water (RW) system. Innowyze's InfoWater Pro software, based on ESRI's ArcGIS platform, was used to update the RW model provided by EVMWD. EVMWD geographic information system (GIS) files were used to update pipelines previously not included in the model.

The four RW systems (Wildomar, Railroad Canyon, Horsethief, and Regional) are modeled in a single InfoWater Pro model. However, scenarios are set up so that each system can be run separately. A screenshot of the RW model is shown on Figure 5.1.

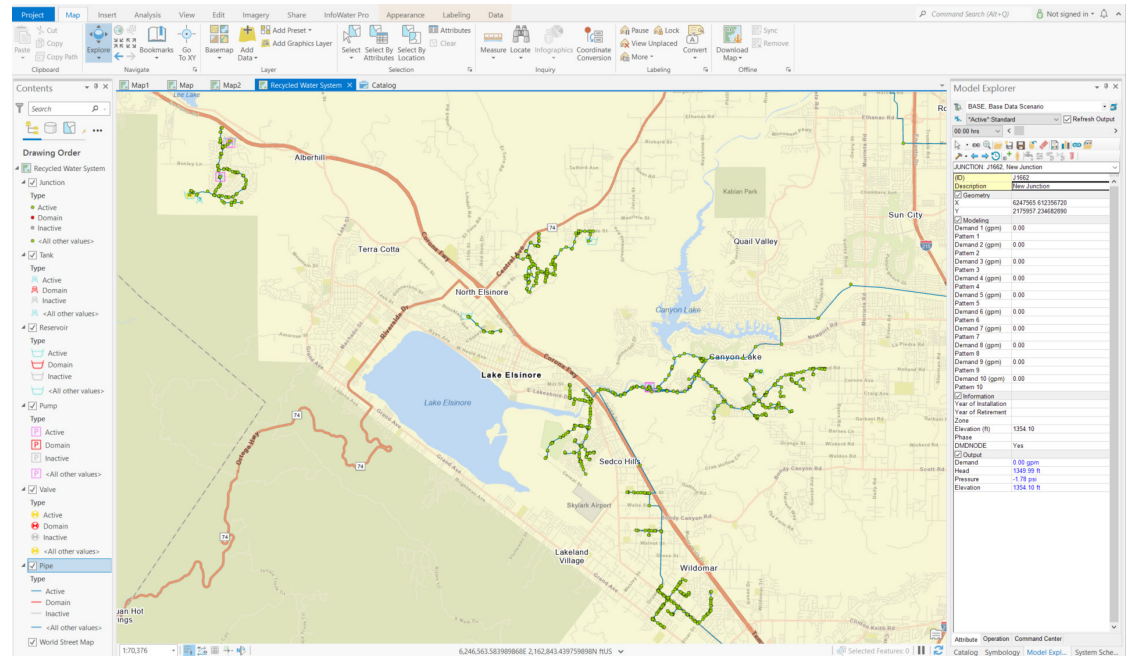

Figure 5.1 RW Model Screenshot

5.2 Hydraulic Model Development

The ArcGIS files (May 2022) for the distribution system network provided by EVMWD were used as the basis for updating the hydraulic model for this Recycled

Water System Master Plan (RWSMP). The model includes all RW pipelines, except service laterals, as well as all the distribution system storage reservoirs, ponds, booster stations, and water reclamation facilities (WRFs) as the major supply sources.

RW mains and their parameters (e.g., diameter, year of installation, material, etc.) were used from the previous model to form the initial pipe network. For pipelines without year of installation information in geographic information system (GIS), the model database fields were left blank. Spatial data such as ground elevations, water demands, pressure zones, and other necessary modeling data were also incorporated into the model using both ArcMap and InfoWater Pro.

5.2.1 Data Collection

Data used for the development of the hydraulic model has been obtained from a variety of sources. Key information included:

- EVMWD GIS database of all RW mains and facilities.
- Dimensions of storage reservoirs.
- Historical RW production records.
- Pump curves and performance tests for booster pumps.
- Historical customer usage records (billing and Advanced Metering Infrastructure [AMI] data).
- Supervisory control and data acquisition data.
- Ground elevation contour lines.
- Street centerline data.
- Aerial photography coverage.
- 2016 hydraulic model.
- 2016 RWSMP.

Additional data was gathered over the course of model development as needed.

5.2.2 Model Coordinate System

All pipelines and facilities included in the hydraulic model were based on the GIS information provided by EVMWD. The spatial representation of the hydraulic model in NAD83 datum, California State Plane Zone VI coordinate system, is consistent with the coordinate system in which EVMWD's GIS data is projected.

5.2.3 Pipelines

All RW pipelines owned by EVMWD were included in the hydraulic model, as well as the RW transmission pipelines owned by Eastern Municipal Water District (EMWD) but limited to the sections that traverse EVMWD's service area. Service laterals are not included in the hydraulic model.

Pipelines and facilities in the model were checked for accuracy, and some pipelines and facilities were redrawn to resolve model connectivity issues. Model attributes for pipelines include the pipe number, pipeline length, diameter, material, roughness coefficient, and the pressure zone. Additional pipelines were drawn in the model, as needed, for a connected and working model.

The pipeline connecting the Wildomar system in the southern section of EVMWD's service area to the rest of the system was added to the model with one fixed-head reservoir at the southern end. The location of this line was obtained from the previous model and GIS data received from EVMWD. Some pipes had a C factor of 50, which was changed to 120 to eliminate unreasonably high head losses.

The existing system model covering all four RW systems includes approximately 1,200 pipeline segments with a combined length of 30 miles, covering the pipelines summarized in Chapter 4. There are more pipelines in the model than listed in Chapter 4 because the model includes pipelines owned by others.

5.2.4 Junctions

Junctions (aka model nodes) are defined as the intersections of two or more pipelines, or at the location where any pipeline changes diameter or material. Attribute information for junctions included elevation, customer demand, and the pressure zone. New junctions were added or deleted, as necessary, to connect pipelines for a working model. The existing system model includes approximately 1,166 junctions.

5.2.5 Storage Tanks

Storage tanks were modeled as cylindrical tanks. Their locations and pressure zones were determined from the system map provided by EVMWD. Attributes such as elevation, diameter, tank height, and installation year were included based on information provided by EVMWD.

These storage tanks also include the storage ponds at Horsethief Canyon WRF, which is modeled as a variable-area tank. The ponds at Canyon Lake Golf Course (CLGC) are not included, as CLGC is merely considered a demand junction.

The existing system model covering all four RW systems includes five storage tanks at four facility sites, covering the storage tanks summarized in Chapter 4.

5.2.6 Booster Pumps

The pump database in the model was populated with a plant number and pump curve for each pump in the system. Manufacturer's pump curve information was provided by EVMWD where the data was available.

The existing system model covering all four RW systems includes 10 pumps at 4 facility sites, covering the booster pumps summarized in Chapter 4.

5.2.7 Water Reclamation Facilities and Ponds

Supply sources, including EVMWD's three WRFs, were modeled as fixed-head reservoirs in the model, which act as an unlimited source of supply.

For the Wildomar system, a fixed-head reservoir was modeled to represent flow from EMWD's Temecula Valley Regional Water Reclamation Facility (TVRWRF). The head was set based on typical pressures at the turnouts.

For the Horsethief Canyon system, Horsethief Canyon WRF is modeled as a fixed-head reservoir and flow control valve since it is assumed that a constant average flow rate is available from the Horsethief Canyon WRF. The percolation pond was included in the model as a pressure-sustaining valve and fixed-head reservoir to maintain a certain level (1,518 feet above mean sea level (ft-msl) in the Horsethief RW reservoir.

For the Railroad Canyon WRF, it is assumed that there will be sufficient RW supplies to meet the needs of the RW demands, as the ponds can be supplied with potable makeup water, if necessary; therefore, the Railroad Canyon WRF was merely modeled as a fixed-head reservoir with unlimited supplies with the operating head of its storage ponds. The ponds at CLGC were not modeled, as the flow into the ponds was modeled as a demand junction.

For the Regional System, the Regional WRF was modeled as a fixed-head reservoir consistent with the operating head of the UV disinfection basin as the UV basin is the supply source to the Lake Recharge pump station.

5.2.8 Facility Elevation Data

Elevations for the facilities in the model were derived from 20-foot topographic contour data provided by EVMWD. Using the contour data, ground elevations were extracted and assigned to all junctions and facilities (except for storage reservoirs) in the model. As all the four RW systems are pressurized, the ground elevations are considered accurate enough for system analysis to represent the pipeline elevations.

Elevations for storage reservoirs were assigned based on information contained on the summary sheets provided by EVMWD. As shown in Table 5.1, the junction elevation ranged from 1,219 feet to 1,745 ft-msl.

Table 5.1 Elevation Range for RW Systems

RW System	Elevation Range	
	Minimum Elevation (feet)	Maximum Elevation (feet)
Wildomar	1,219	1,347
Railroad Canyon	1,312	1,829
Horsethief Canyon	1,255	1,745
Regional	1,265	1,591

5.2.9 Demand Allocation

Most of the customer meters were already geographically distributed in a shapefile provided by EVMWD that links customer accounts to the Riverside County Assessor's Parcel Number (APN). For accounts where the APN information was not available, street addresses were used to assign meter locations. The remaining customer demands were geographically distributed through a process called geocoding. The average annual consumption from each customer account was geographically located using the street addresses in the billing data and street centerline GIS coverage. The geocoding process consisted of using tabular records and geographic feature classes, such as streets, to identify locations within the tabular data. The demands were then scaled up to account for the nonrevenue water in the system.

After the customer meters were geographically located, demands were allocated to the model junctions based on proximity to the customer meters using the demand allocator tool in InfoWater. Demand junctions were selected based on pressure zone boundaries and proximity to meter locations. All junctions associated with RW facilities were excluded as demand junctions.

5.2.10 Diurnal Pattern

A diurnal pattern represents the demand fluctuation in a water system over a 24-hour period. Diurnal patterns for EVMWD's RW distribution were created based on hourly AMI data received from EVMWD for the summer of 2021 (June through August). The diurnal pattern calculations were based on the actual demand values, which were summed for a total system hourly demand and then normalized into a pattern. Diurnal patterns were developed for all four systems and are presented in Chapter 3 in more detail.

Diurnal patterns input in the model for the Wildomar system and the Railroad Canyon system (Cottonwood diurnal pattern) are shown on Figure 5.2 and Figure 5.3, respectively. The Cottonwood diurnal pattern also was assigned to the Horsethief system since there is insufficient information available in Horsethief to

develop a diurnal pattern. The diurnal pattern for Horsethief was developed based on the AMI data available for summer of 2021 and is shown on Figure 5.4.

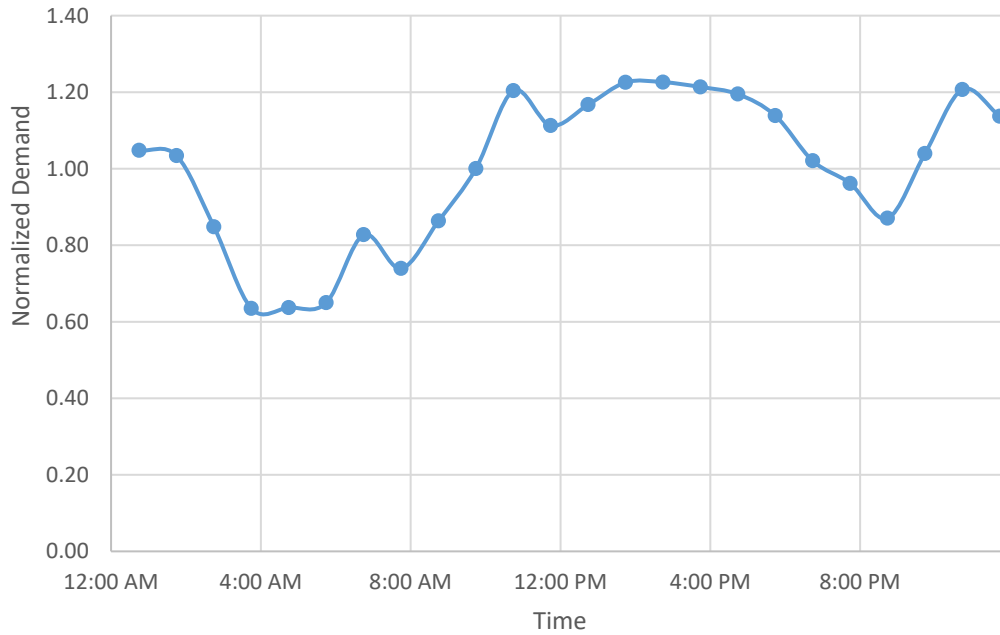

Figure 5.2 Wildomar System Diurnal Pattern

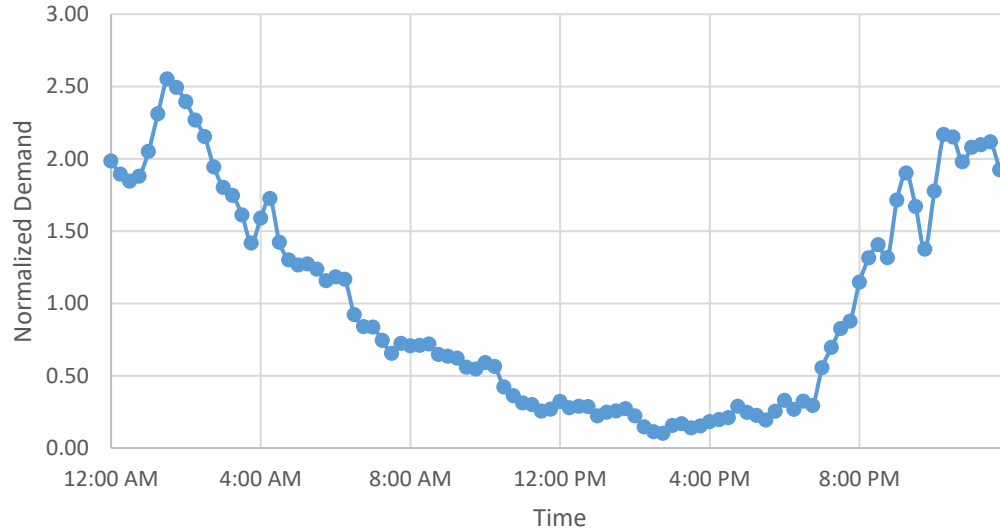

Figure 5.3 Cottonwood Diurnal Pattern (Used for Railroad Canyon and Horsethief Systems)

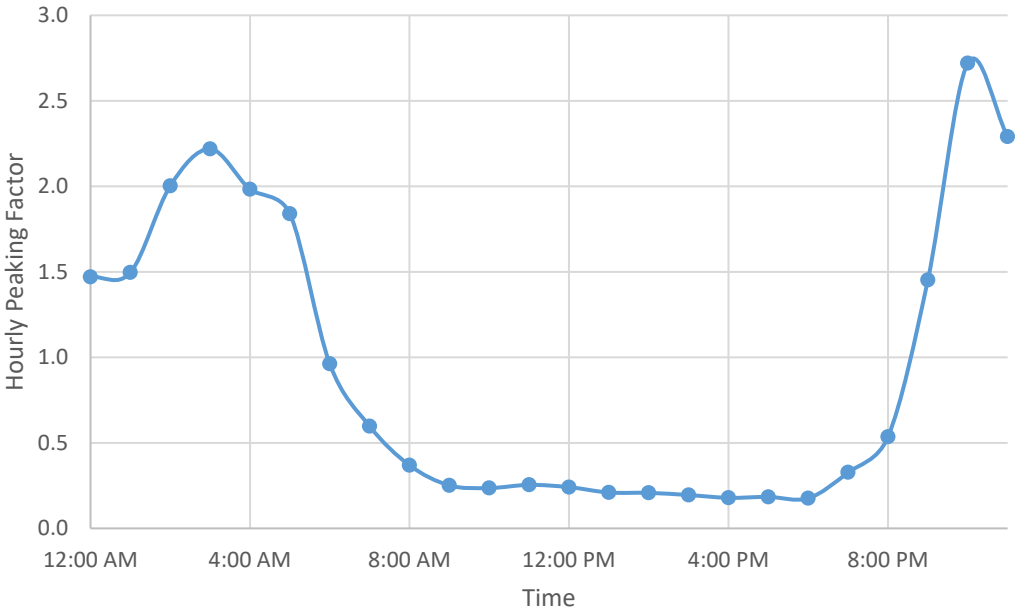

Figure 5.4 Horsethief Diurnal Pattern (AMI Data for Summer of 2021 Used)

5.3 Model Calibration

Model calibration was not within the scope of this plan. The model was reviewed to confirm that the results are reasonable and meet expected norms for a RW system. In select locations, pressures were verified with EVMWD operations staff to confirm that the model's predicted pressures were indeed reasonable. Changes were made, where necessary, to confirm that reasonable results were being obtained. Based on the spot checking of results and the primary focus on the hydraulic modeling on growth-related improvements, the model was considered to be of sufficient quality for hydraulic evaluation of the RW system.

-This Page Intentionally Left Blank-

Chapter 6

PLANNING AND EVALUATION CRITERIA

This section presents the design criteria and methodologies for analysis used to evaluate the existing recycled water (RW) distribution system and its facilities and to size future improvements.

6.1 Design Criteria

Planning criteria are established for the evaluation of the Elsinore Valley Municipal Water District's (EVMWD/District) RW system. The criteria are developed using the typical planning criteria used in the systems of similar water utilities, local codes, engineering judgment, and commonly accepted industry standards. The "industry standards" are typically ranges of values that are acceptable for the criteria in question and, therefore, are used more as a check to confirm that the values being developed are reasonable. The design criteria and analytical methodologies used to conduct this evaluation are presented in Table 6.1.

Table 6.1 RW System Evaluation Criteria

Description	Value	Units
Maximum Pressure	125	psi
Minimum Pressure	40	psi
Maximum Pipeline Velocity		
Transmission and Distribution Pipelines	6	fps
Pumping Station Suction Piping	8	fps
Reservoir Storage Volume	As Needed	
Supply Capacity		
By Pressure Zone, for Zones With Gravity Storage	MDD With Firm Transfer/Booster Capacity Between Zones	
By Pressure Zone, for Zones Without Gravity Storage	PHD with Firm Transfer/Booster Capacity Between Zones	

Notes:

Abbreviations: fps-feet per second, MDD-maximum day demand, PHD- peak hour demand, psi-pounds per square inch.

6.1.1 System Pressures

Minimum system pressures are evaluated under PHD conditions. The minimum pressure criterion for normal PHD conditions is 40 psi. The pressure analysis is

limited to demand nodes in the hydraulic model, because only locations with service connections need to meet such pressure requirements.

The hydraulic analysis is performed using the 24-hour extended period simulation model developed for the District as part of this project, which is based on the District's geographic information system (GIS) and demands, operating conditions, and facility controls.

6.1.2 Pipeline Velocities

Pipeline velocities are evaluated for two different conditions as listed in Table 6.1. The maximum velocity for transmission and distribution system pipelines is 4 fps provided that the system pressures are sufficient. This criterion is intended to minimize head loss.

The minimum pipeline size is 6-inch diameter.

6.1.3 Storage

Storage needs in a RW system is the quantity of water that is required to balance daily fluctuations in demand and water production. Many recycled systems are usually designed to supply the average demand on the maximum day and use reservoir storage to supply water for peak hour flows that typically occur in the nighttime and early morning hours. This operational storage is replenished during off-peak hours that typically occur during the day, when the demand is less. However, the need for storage in a RW system is dependent on system configuration, the available supply of water versus the demands, and the availability of alternate water supplies. Therefore, no specific criteria are set for storage for RW systems and will be evaluated on a case-by-case basis in each system.

6.1.4 Pumping Capacity

The District's RW system is evaluated for the adequacy of booster pumping capacity under existing and build-out demand conditions. For pressure zones within the District's service area with reservoir storage, there should be adequate booster pumping capacity to provide firm pumping capacity sufficient to meet MDD. Firm capacity is defined as the combined pump capacity at the pump station with the largest booster pump out of service. For zones without storage, there should be adequate booster pumping capacity to provide firm capacity to meet PHD.

Chapter 7

EXISTING SYSTEM ANALYSIS

This chapter includes the existing system analysis for the recycled water (RW) system. As previously described in Chapter 4, Elsinore Valley Municipal Water District's (EVMWD/District) RW service consists of four separate systems namely Wildomar, Railroad Canyon, Horsethief Canyon and Regional. This chapter is similarly organized by RW system and includes the information on the booster pump capacity, storage capacity, pressures and velocities for each system and recommendations, if any, based on the conclusions of the pumping and storage calculations.

7.1 Wildomar System Existing System Analysis

The amount of flow available to EVMWD in the Wildomar region at the beginning of each fiscal year is based on the actual average daily wastewater flow contributed to the Santa Rosa Water Reclamation Facility (WRF) during the previous fiscal year. There are two operational constraints on the RW supply to the Wildomar system:

1. Total instantaneous flow rate cannot exceed 2.0 million gallons per day (mgd), which equates to 1,389 gallons per minute (gpm). Per the Memorandum of Understanding between EVMWD, Eastern Municipal Water District (EMWD), and Rancho California Water District (RCWD) signed in 2004 for 1.54 mgd and the additional 0.46 mgd purchase agreement between the three parties in 2016.
2. The monthly average flow during a fiscal year cannot exceed the actual annual average wastewater flow contribution to Santa Rosa WRF during the previous fiscal year.

Based on the historical data available from 2017 to 2021, the monthly average flows to the Santa Rosa WRF have remained relatively constant with an average flow of 0.84 mgd before the decommissioning of the Washington Avenue Lift Station in July 2022. Since July 2022, the flows going to Santa Rosa WRF have increased to 1.1 mgd. Hence, the assumption is that EVMWD has had the rights to 0.84 mgd of RW per year to be delivered by the 48-inch diameter Temecula Valley Recycled Water Pipeline (TVRWP) from the Santa Rosa WRF. However, this is not a fixed amount and will increase based on growth and additional water being sent to Santa Rosa WRF.

7.1.1 Booster Pump Capacity Evaluation

There are no booster pumps in the Wildomar system. Under existing system conditions, the supply from the TVRWP is at sufficient pressure (approximately 121 pounds per square inch [psi] at the delivery point) so that additional booster pumps are not needed.

7.1.2 Storage Capacity Evaluation

There is no existing storage in the Wildomar system. The historical peak hour demands (PHDs) derived from historical RW demand data are 896 gpm and less than the maximum instantaneous flow rate of 1,389 gpm as per the maximum capacity available in the TVRWP and therefore storage is not needed for the Wildomar system under existing system conditions.

7.1.3 System Pressure and Velocities

For the Wildomar system, the pressures and velocities were obtained from the model by running a maximum day demand (MDD) scenario for a 24-hour period. System pressures were only evaluated at the demand nodes, while velocities were evaluated in all the pipes. The results are shown on Figure 7.1.

The predicted pressures were compared to the pressure criteria listed in Chapter 6, which define a minimum pressure of 40 psi and maximum pressure of 125 psi.

The minimum pressure in Wildomar is 40 psi at the demand node at Canyon Drive and Orange Street while the maximum pressure is about 95 psi at the demand node at Palomar Street and McVicar Street, which is within the District's maximum pressure criteria.

The maximum velocity for pipelines listed in Chapter 6 is 6 feet per second (fps) for transmission and distribution mains and 8 fps for all suction piping for pump stations. Wildomar does not have any pump stations and the maximum velocity in the Wildomar system is 3.6 fps in the pipe near Palomar St. and Gruwell Street, which meets the planning criteria.

7.1.4 Recommendations

There are no recommendations for the Wildomar system to address existing system deficiencies.

The pressures for demand nodes (from the hydraulic model) and velocities for pipes in Wildomar are shown on Figure 7.1.

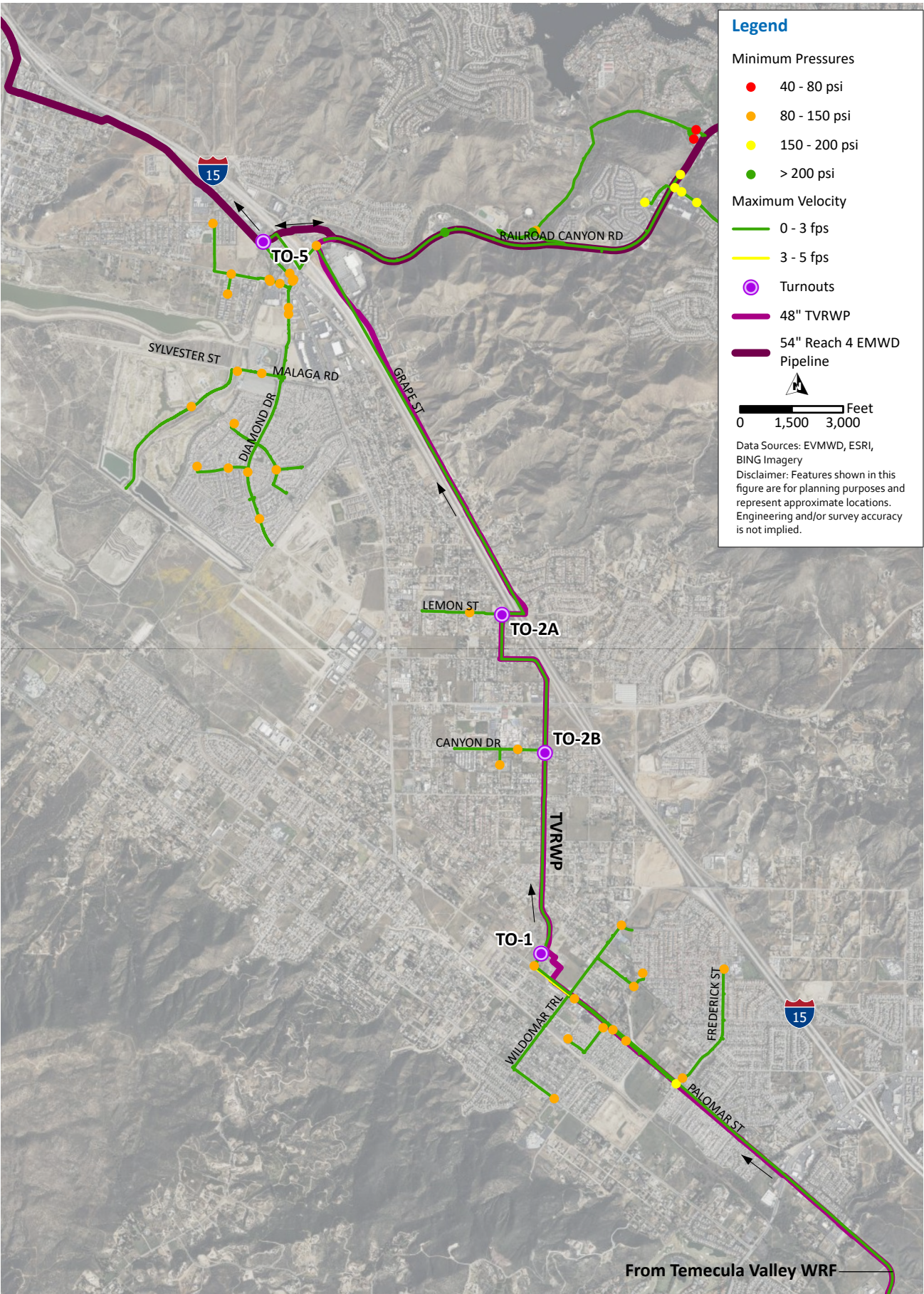

Figure 7.1 Wildomar RW System Pressure and Velocity Results

-This Page Intentionally Left Blank-

7.2 Railroad Canyon System Existing System Analysis

RW from the Railroad Canyon WRF serves the City of Canyon Lake for irrigating median islands and parkways, Canyon Lake Golf Course (CLGC) through a dedicated pipeline and multiple customers in the Canyon Hills community through a separate system referred herein as the Cottonwood System (1850 Zone).

The Railroad Canyon WRF has had an average inflow into the WRF of 1.03 mgd from 2017 to 2021 which is lower than the design capacity of 1.3 mgd and the operational capacity of 1.12 mgd. It is assumed that the inflow into the Railroad Canyon WRF is generally equal to the effluent from the WRF. Railroad Canyon WRF flow is sufficient to meet the RW demands in the winter months but not during the summer months. Therefore, EVMWD has an agreement with EMWD to purchase supplemental RW from its Reach 4 pipeline for the CLGC. The average supplemental purchase from 2017 to 2021 has been 0.14 mgd (112 acre-feet per year [AFY]).

The historical average RW demands include both the demand for the Canyon Hills community served via the Cottonwood System (which accounts for approximately 60 percent of the demand) and the CLGC. Both have a strong seasonal demand with the summer demand being approximately 2 and 5 times higher than the average winter demand, respectively. The five year average for the Cottonwood System demand was 0.36 mgd and that for the CLGC system was 0.24 mgd, while the MDD was 0.97 mgd and 0.65 mgd, respectively. It can be concluded that although the Railroad Canyon WRF flows are not sufficient to meet the peak summer RW demands, the ability to supplement supplies from EMWD's Reach 4 pipeline to the CLGC allows EVMWD to meet all system demands under existing conditions. Supplemental potable water is also used to primarily address incidental needs due to maintenance/short-term lapses.

7.2.1 Booster Pump Capacity Evaluation

The Railroad Canyon system has five booster pumps at the Railroad Canyon WRF. Two pumps of the CLGC Pump Station pump from the Railroad Canyon WRF to the CLGC ponds. The other three pumps (Cottonwood Pump Station) pump from the Railroad Canyon WRF to Zone 1850 to serve the Canyon Hills community as shown on the schematic in Chapter 4.

7.2.1.1 CLGC Pump Station Pumps

The CLGC Pump Station needs capacity to deliver MDD of the CLGC, as Ponds 4 and 5 at the CLGC have storage to account for daily diurnal demand fluctuations. As seen in Table 7.1, there is sufficient capacity in the CLGC Pump Station (firm capacity of 700 gpm) to meet MDD (450 gpm).

There is a possibility that the CLGC Pond Nos. 4 and 5 might be taken out of service in the future due to planned development. If this is the case, the CLGC Pump Station pumps will need to be able serve PHD. If the ponds are taken out of service, the CLGC pump station would need to be expanded with an additional booster pump to be able to supply the required PHD of 1,147 gpm using firm capacity.

Table 7.1 Railroad Canyon WRF System Capacity Evaluation

Category	CLGC Pump Station (gpm)	Cottonwood Pump Station (gpm)
ADD	167	250
MDD	450	675
PHD	1,147	1,721
Number of Booster Pumps	2	3
Capacity of Each Booster Pump	700	400
Firm Capacity (From Hydraulic Model)	700	746
Excess Capacity	250	71

Notes:

Abbreviations: ADD - average day demand.

7.2.1.2 Cottonwood Pumps

The Cottonwood Pump Station needs to have capacity to deliver MDD of the Canyon Hills system, with demands above MDD supplies from storage tanks. As seen in Table 7.1, there is sufficient capacity in the Cottonwood Pump Station (firm capacity of 746 gpm) to meet MDD (675 gpm).

It can be concluded that the District has sufficient pump station capacity to meet existing demands and no recommendations are made.

7.2.2 Storage Capacity Evaluation

For the Railroad Canyon System, storage capacity evaluation was performed to determine the amount of storage needed for the Cottonwood system. Based on the peaking factor (PF) of 2.7, the existing MDD is 675 gpm for the Cottonwood system. The demand was calculated over a 24-hour period using the hourly factors from the Cottonwood demand diurnal curve. The supply was assumed to be a constant value equal to the MDD. The storage needed at each hour was the difference between the MDD and required supply converted to gallons. The storage calculation shows required total storage in the Cottonwood Zone is 386,000 gallons, including 20 percent for emergency and dead storage needs. Compared to the existing storage capacity of 2.6 million gallons (MG), there is sufficient storage in the Cottonwood Zone to meet storage needs as shown on Figure 7.2.

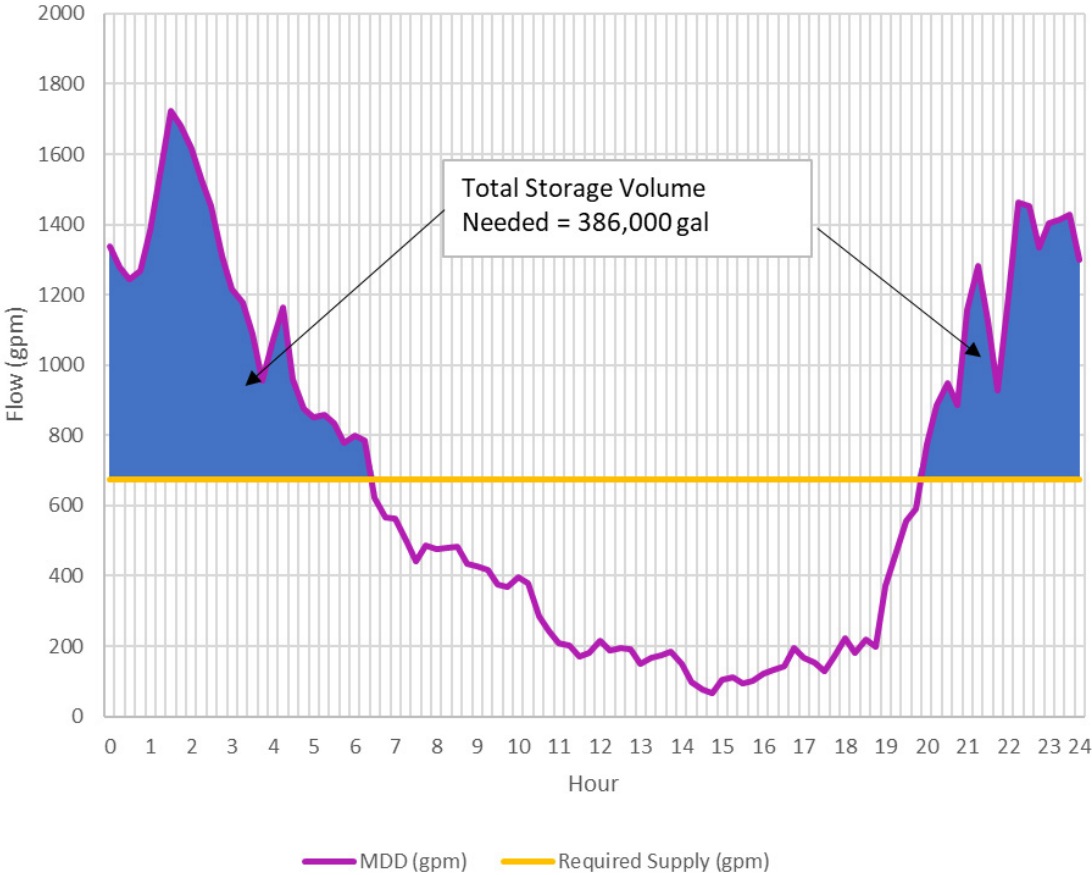

Figure 7.2 Cottonwood System Storage Needs

A storage capacity evaluation was performed for the CLGC ponds. The demand was calculated over a 24-hour period using the hourly factors from the Cottonwood demand diurnal curve. The required supply was assumed to be a constant value equal to the MDD. The storage needed at each hour was the difference between the MDD and required supply converted to gallons. The calculation shows required total storage of 730,000 gallons if the CLGC ponds are taken out of service as shown in Figure 7.3, including 20 percent for emergency and dead storage needs.

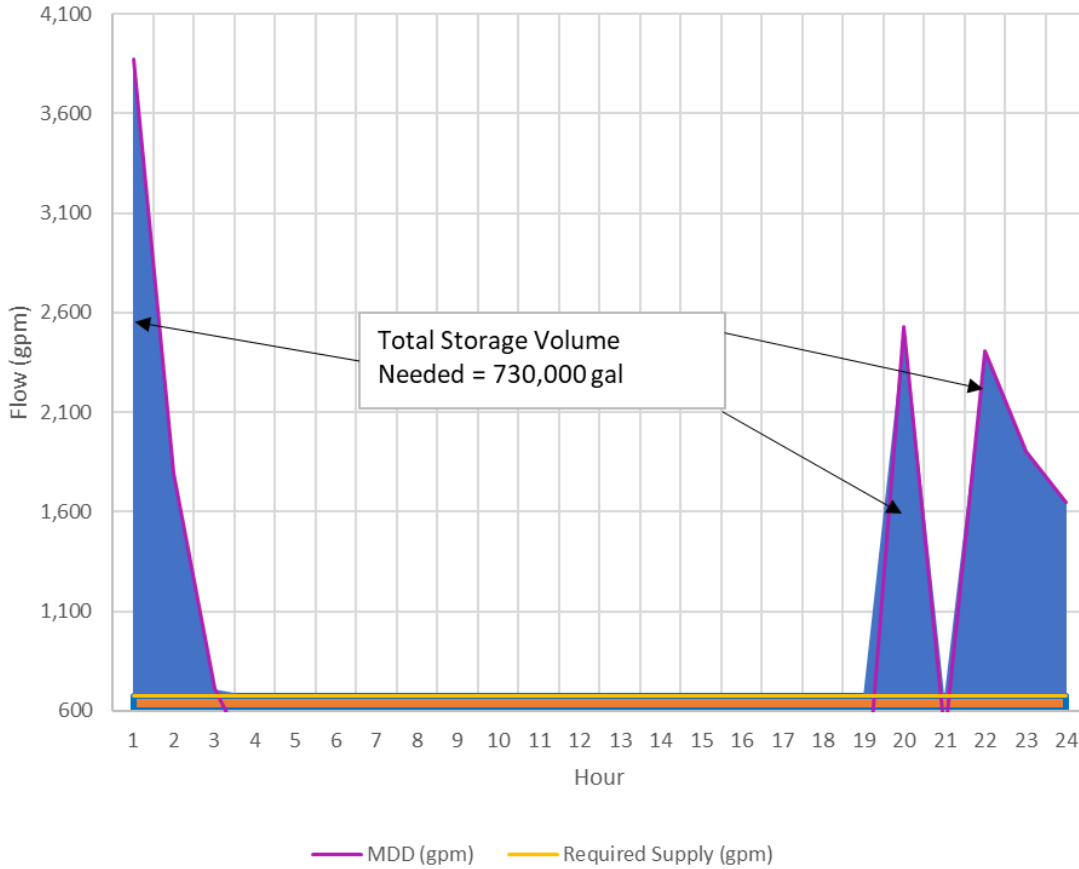

Figure 7.3 Railroad Canyon WRF Storage Needs if CLGC Pond Nos. 4 and 5 Out of Service

There are also storage ponds at Railroad Canyon WRF to balance the effluent flows from the WRF with RW demands through the pump stations. As shown on Figure 7.4, a total of 150,000 gallons are needed at the storage ponds at Railroad Canyon WRF including 20 percent for emergency and dead storage needs. There are two lines ponds each with a capacity of 1.57 MG which are used for storage. The required capacity of 121,000 gallons is significantly less than the existing storage pond capacity of 3.14 MG.

It is concluded that the District has sufficient storage to meet existing demands and no recommendations are made.

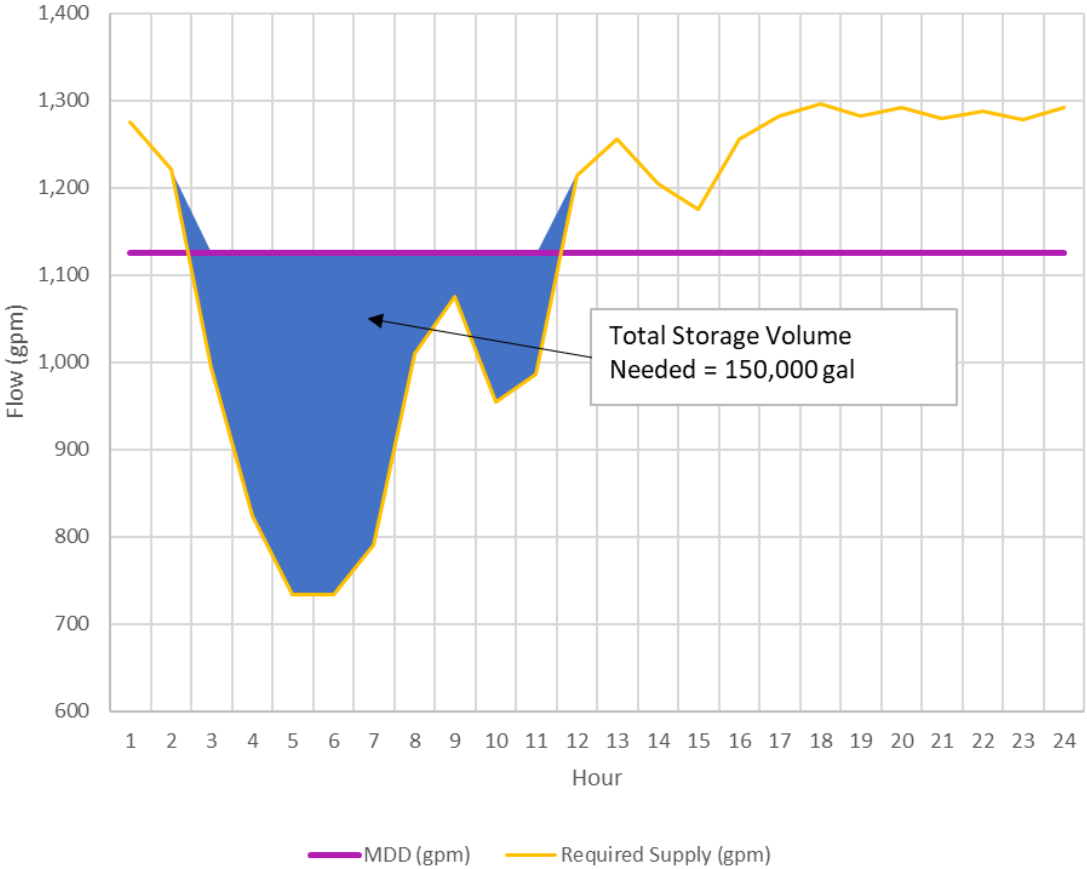

Figure 7.4 Railroad Canyon WRF Storage Needs

7.2.3 System Pressure and Velocities

Like the Wildomar system, the pressures and velocities for the Railroad Canyon System were obtained from the model by running a MDD scenario for a 24-hour period. The pressures were evaluated at the demand nodes only whereas all pipes in the system were considered for velocity considerations. The results are shown on Figure 7.5.

The pressures and velocities from the model were compared to the pressure and velocity criteria listed in Chapter 6, the minimum pressure of 40 psi and maximum pressure of 125 psi. The minimum pressure in The Railroad Canyon system is 43 psi while the maximum pressure is 227 psi. The wide range in pressures is primarily caused by topographic changes with ground elevations ranging from 1,297 to 1,829 feet above mean sea level (ft-msl). This 532 feet elevation change contributes to 190 psi difference under static demand conditions. As shown in Figure 7.5, system pressures exceed the evaluation criteria in the majority of the Railroad Canyon system.

The maximum velocity for pipelines as defined in Chapter 6 is 6 fps for transmission and distribution mains and 8 fps for all suction piping for pump stations. The maximum velocity for this system is 5.9 fps, which meets the planning criteria range. The high pressure in the main line from the Cottonwood Pump Station is due to high hydraulic grade line needed to serve customers in the higher elevations. EVMWD should monitor the condition of the pipe carefully and replace it with appropriate pressure class pipe if conditions indicate the possibility of failure. The pressures for demand nodes (from the hydraulic model) and velocities for pipes in Railroad Canyon system are shown on Figure 7.5.

7.2.4 Recommendations

Although the pressures are high, there are no recommendations for the Railroad Canyon system to address existing system deficiencies. EVMWD should monitor the high-pressure pipelines closely for leaks and may need to replace some of the pipelines sooner than expected. It is possible that some of the pipelines were not designed for the pressures that are in the pipelines.

7.3 Horsethief Canyon System Existing System Analysis

The Horsethief Canyon WRF, which has an average design capacity to treat 0.5 mgd, receives wastewater from the surrounding areas and treated an average flow of approximately 0.35 mgd during the last five years. Over these years, the Horsethief Canyon System has seen a peak RW demand of 0.31 mgd during the summer months and 0.05 mgd during the winter months. Planned expansion at the Horsethief Canyon WRF will increase the plant's existing capacity from approximately 0.5 mgd to a total of 0.8 mgd to accommodate pending developments in the area. RW in the Horsethief service area was formerly augmented by water pumped from the Barney Lee well. However, this well has not been consistently used since 2008, was not used between 2017 and 2021, but was used in 2022.

The Horsethief Canyon System consists of two pressure zones, the 1518 Zone and the 1844 Zone as shown on Figure 4.6 in Chapter 4. Based on the model data, the 1518 Zone accounted for 20 percent of the total demands in the Horsethief Canyon System and Zone 1844 Zone accounted for the remaining 80 percent of the system demands.

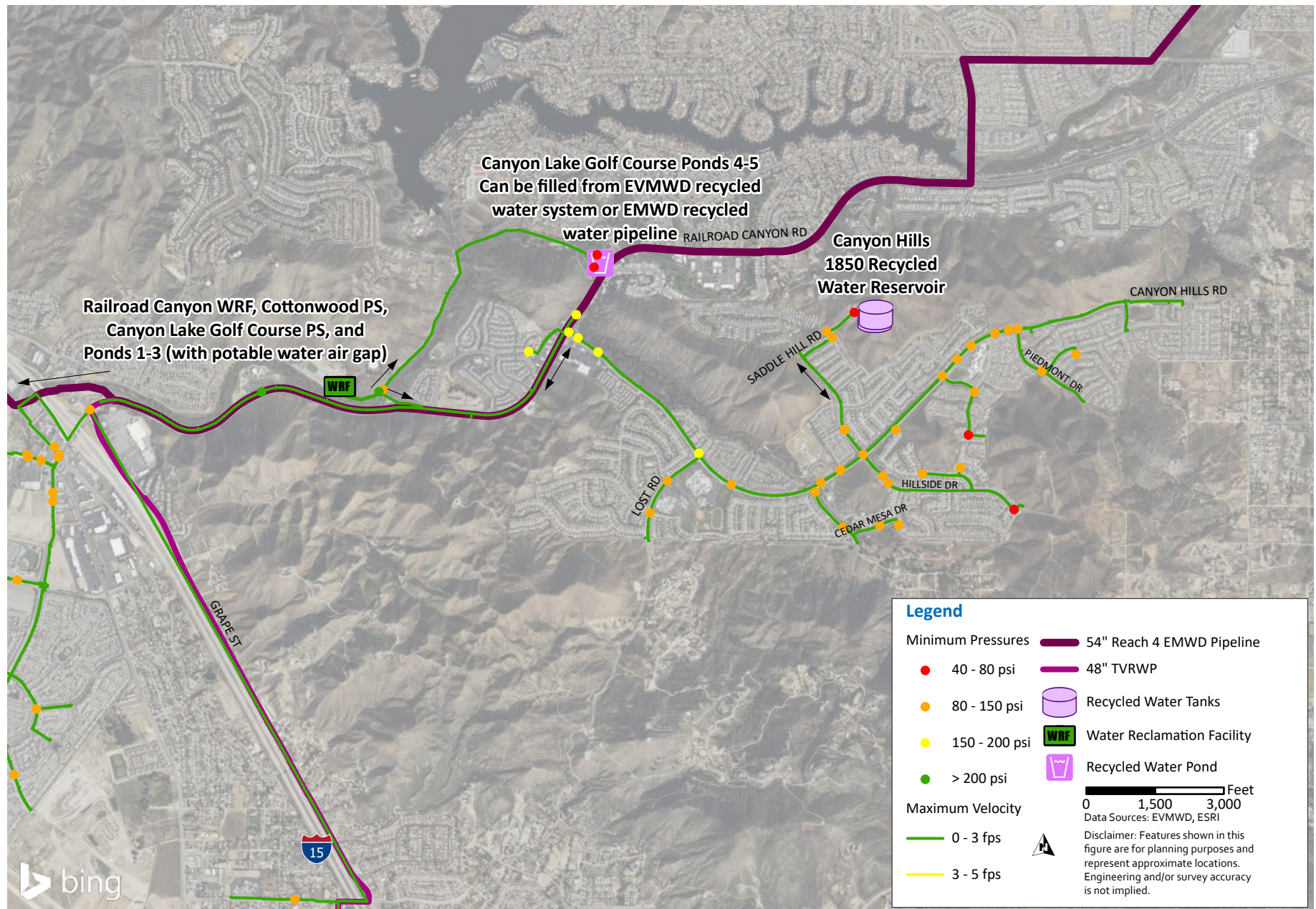

Figure 7.5 Railroad Canyon RW System Pressure and Velocity Results

-This Page Intentionally Left Blank-

7.3.1 Booster Pump Capacity Evaluation

The Horsethief Canyon System has five booster pumps at two locations. There are two pumps at the Horsethief 1 Pump Station which pump from the Horsethief WRF to the 1518 Zone. The other three pumps are at the Horsethief 2 Mid-Range Pump Station (MRPS), which pump from 1518 Zone to 1844 Zone.

7.3.1.1 Horsethief 1 Pumps

The Horsethief 1 Pump Station needs to have capacity to deliver flow for the following three conditions:

- MDD of both the 1518 and 1844 Zones.
- PHD of the 1518 Zone since there is insufficient storage in the 1518 Zone (discussed in Section 7.3.2.1).
- Pump all the Horsethief Canyon WRF effluent to the RW reservoir for storage.

As seen in Table 7.2, there is sufficient capacity in the Horsethief 1 Pump Station (firm capacity of 295 gpm) to deliver average dry weather flows (ADWF) from the Horsethief Canyon WRF (243 gpm) and to deliver existing 1518 Zone PHD (188 gpm). There is insufficient firm capacity, however, to deliver MDD (378 gpm) and an additional parallel pump will be required. The deficiency is 83 gpm under existing conditions.

7.3.1.2 Horsethief 2 (Mid-Range) Pumps

The Horsethief 2 MRPS needs to have capacity to deliver flow for the following two conditions:

- MDD of the 1844 Zone.
- Pump all the Horsethief Canyon WRF effluent to the RW reservoir for storage.

As seen in Table 7.2, there is sufficient capacity in the Horsethief 2 Pump Station (firm capacity of 690 gpm) to deliver 1844 Zone MDD (304 gpm) and to deliver ADWF from the Horsethief Canyon WRF (334 gpm) to the percolation pond.

Table 7.2 Horsethief System Booster Pump Capacity Evaluation

Category	Horsethief 1 Pump Station (gpm)	Horsethief 2 Pump Station (gpm)
Number of Booster Pumps	2	3
Capacity of Each Booster Pump	334	334
Pumping Firm Capacity	292	690
Pumping From Zone	Horsethief WRF	1518 Zone
Pumping To Zone	1518 Zone	1844 Zone
ADWF	243	243
MDD of Zone	74	304
MDD of Higher Zone	304	0
MDD to be Delivered	378	304
PHD of Zone	188	775
ADWF Pump Surplus/Deficit	52	447
MDD Pump Surplus/Deficit	-86	386
PHD Pump Surplus/Deficit	106	Not Applicable ⁽¹⁾
Controlling Surplus/Deficit	-86	386

Notes:

(1) PHD for Horsethief 2 Pump Station not applicable since there is a storage tank in the 1844 Zone to meet PHD.

7.3.2 Storage Capacity Evaluation

For the Horsethief Canyon RW System, the storage capacity evaluations were performed for each zone (1518 Zone and 1844 Zone) and for the Horsethief WRF to determine the storage needs for each zone and the WRF.

7.3.2.1 1518 Zone

Based on the ADD of 28 gpm and a PF of 2.7, the existing MDD for the 1518 Zone is 74 gpm. The demand was calculated over a 24-hour period. The supply was assumed to be a constant value equal to the MDD. The storage needed at each hour was the difference between the demand and supply converted to gallons. For the 1518 Zone, a storage of 45,000 gallons is needed, including 20 percent for emergency and dead storage needs, and is shown on Figure 7.6. Compared to an existing storage capacity of 5,000 gallons in the MRPS wet well, there is insufficient storage in the 1518 Zone. However, this storage deficiency is mitigated by the recommended pumping project at the Horsethief 1 Pump Station, available storage at the one Horsethief Canyon WRF storage pond, and supplemental water from the Barney Lee Wells as needed and discussed in Section 7.3.2.3.

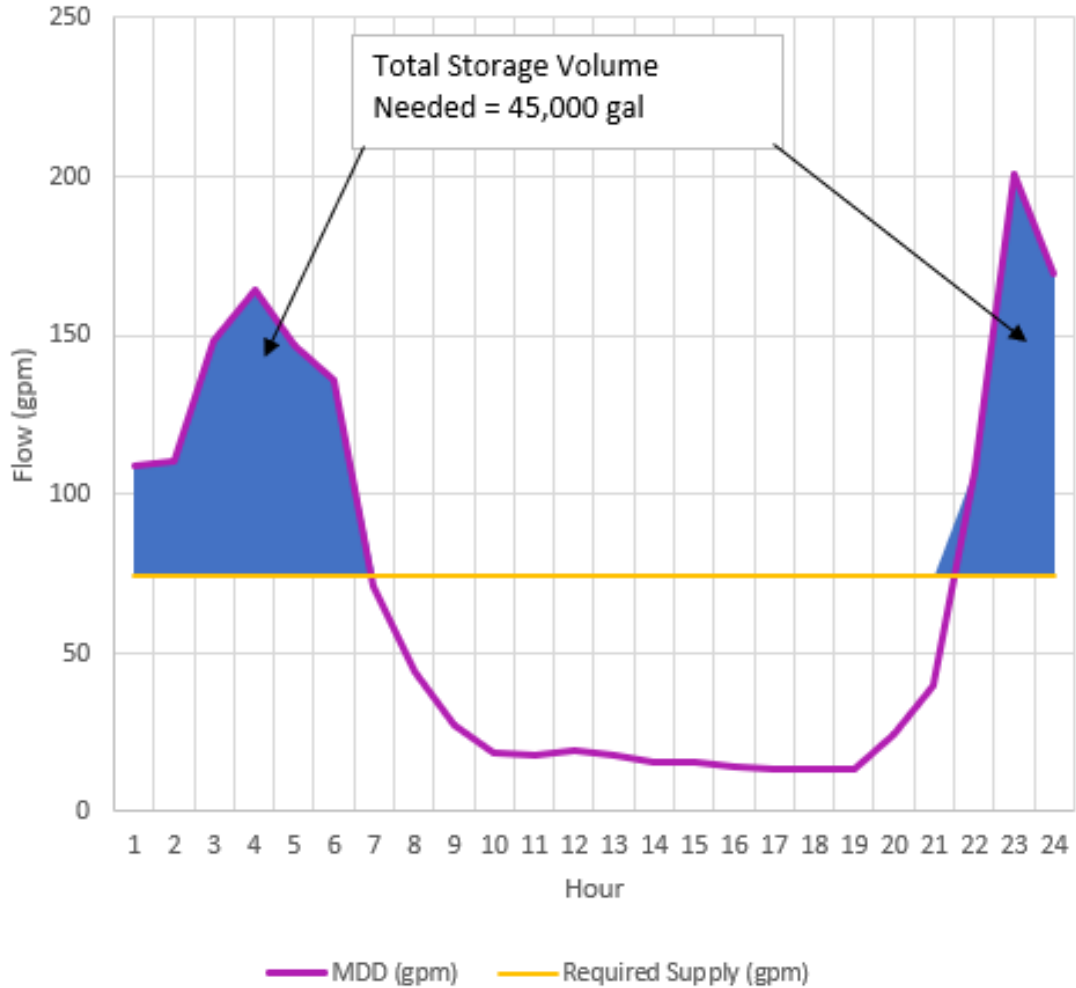

Figure 7.6 Horsethief Canyon RW System Storage Needs for 1518 Zone

7.3.2.2 1844 Zone

Based on the ADD of 140 gpm and a PF of 2.7, the existing MDD for the 1844 Zone is 378 gpm. The demand was calculated over a 24-hour period using the hourly factors from the Cottonwood diurnal curve. The supply was assumed to be a constant value equal to the MDD. The storage needed at each hour was the difference between the demand and supply converted to gallons. For the 1844 Zone, storage of 183,000 gallons is needed, including 20 percent for emergency and dead storage needs, and is shown on Figure 7.7. Compared to an existing storage capacity of 170,000 gallons in the Horsethief Canyon Reservoir, there is insufficient storage in the 1844 Zone.

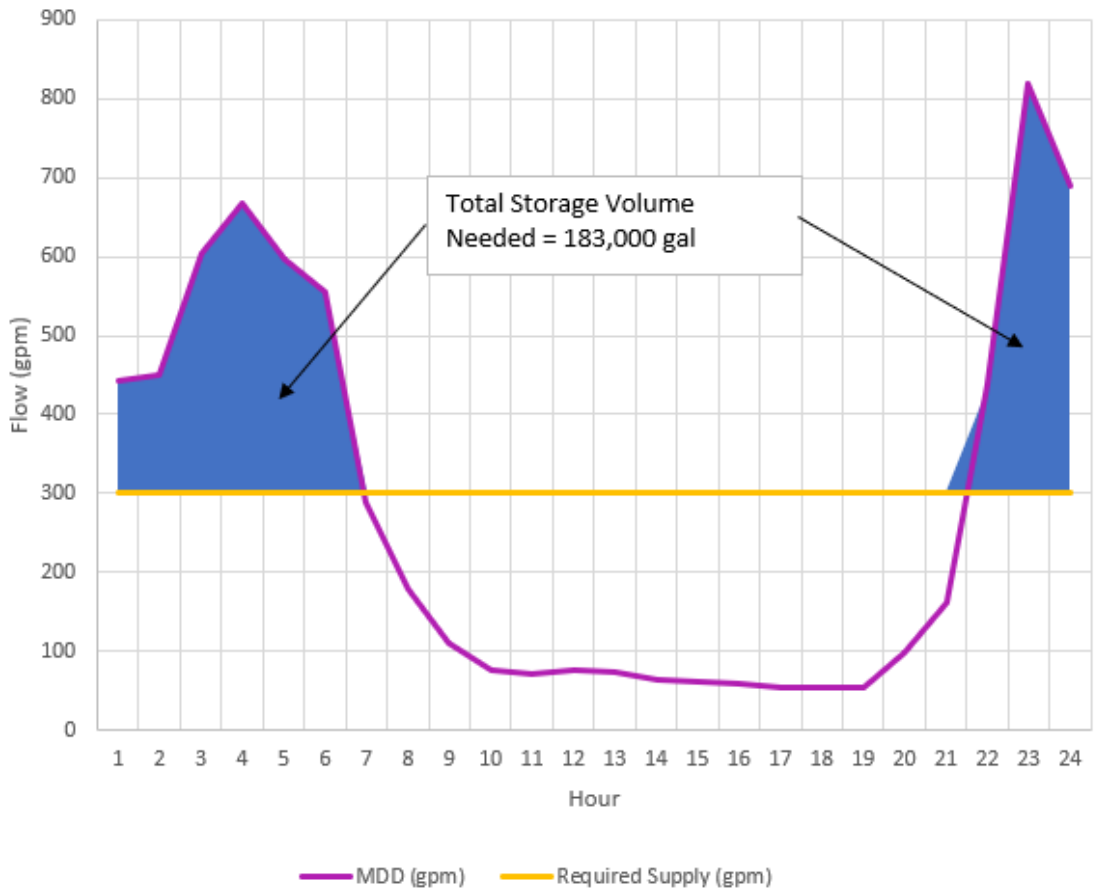

Figure 7.7 Horsethief System Storage Needs for 1844 Zone

7.3.2.3 Horsethief Canyon WRF Storage Ponds

There is one effluent storage pond at Horsethief Canyon WRF to balance the effluent flows from the WRF with RW demands through the pump stations. The other storage pond is for secondary effluent. The remaining two on-site ponds are used for off-spec/stormwater purposes only. As shown on Figure 7.8, a total of 96,000 gallons are needed, including 20 percent for dead storage, at the storage ponds Horsethief WRF, which is significantly less than the existing storage pond capacity of 333,000 gallons. This excess storage capacity in the Horsethief Canyon WRF storage ponds is also sufficient to meet the deficiency in storage in the 1518 Zone if there is sufficient pumping capacity at the Horsethief WRF Pump Station.

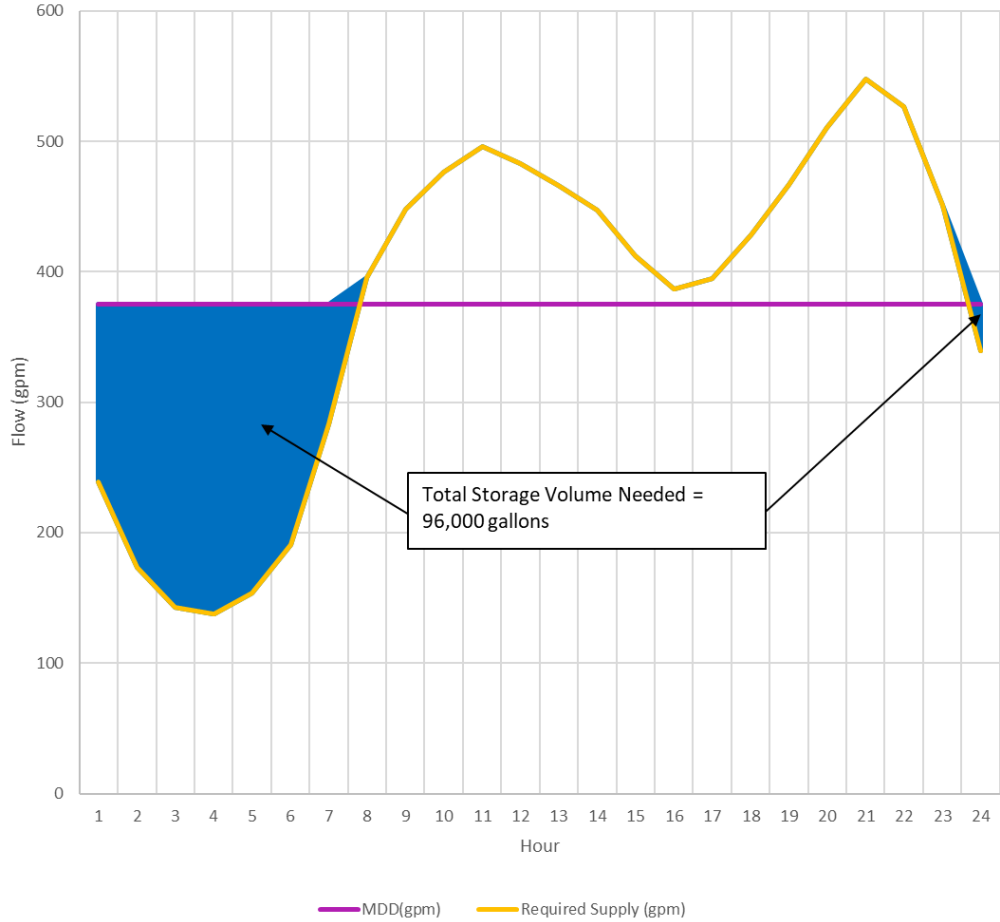

Figure 7.8 Horsethief System WRF Storage Needs

7.3.3 System Pressure and Velocities

Like the Wildomar system, the pressures and velocities for the Horsethief Canyon System were obtained from the model by running the MDD for a 24-hour period. The pressures were only evaluated at the demand nodes, while velocities were evaluated in all pipes in the system. The results are shown on Figure 7.9.

The pressures and velocities from the model were compared to the pressure and velocity criteria listed in Chapter 6, the minimum pressure of 40 psi and maximum pressure of 80 psi. The minimum pressure in the Horsethief Canyon System is 43 psi while the maximum pressure is 172 psi.

The maximum velocity for pipelines as decided in Chapter 6 is 6 fps for transmission and distribution mains and 8 fps for all suction piping for pump stations. The maximum velocity in the Horsethief region is 3.7 fps in the pipe just downstream of the Horsethief Canyon WRF, which is below the planning criteria range.

The pressures for demand nodes (from the hydraulic model) and velocities for pipes in the Horsethief Canyon RW System are shown on Figure 7.9.

7.3.4 Recommendations

There are no recommendations for the Horsethief Canyon system to address existing system deficiencies although there are some high pressures.

7.4 Regional System Existing System Analysis

EVMWD owns and operates the Regional WRF which has a nominal average design capacity of 8.0 mgd and produces an average of 6.1 mgd. The Regional WRF is undergoing an expansion for an average daily capacity of 12 mgd. EVMWD is required to discharge a minimum of 0.5 mgd to the Temescal Creek to maintain downstream riparian habitat. The remaining plant flow is typically discharged to Lake Elsinore to maintain the lake levels for recreational purposes based on an agreement between EVMWD and the City of Lake Elsinore.

When the lake level exceeds 1,247 ft-msl, RW can no longer be discharged to the lake and the entire plant flow needs to be discharged to Temescal Creek.

Over the past five years, the Regional WRF produced a relatively consistent flow of approximately 6.1 mgd of RW with generally higher flows in the winter and slightly lower flows in the summer. A small portion of RW is used internally at the Regional WRF and adjoining office building for landscape irrigation and auxiliary plant water use, accounting for less than 5 AFY of average annual demand.

7.4.1 Booster Pump Capacity Evaluation

The Lake Recharge Pump Station has three pumps each with pumping capacity of 2,950 gpm per pump. However, the pumping capacity is constrained by the pipeline to DP-002A (pipeline to the lake), which has a max flow capacity of 10 mgd.

It can be concluded that the pump station has sufficient capacity to deliver the average daily flow of 7.5 mgd of water from Regional WRF to Lake Elsinore.

7.4.2 Storage Capacity Evaluation

There is no existing storage in the Regional system.

7.4.3 System Pressure and Velocities

The only customer in the Regional System besides discharge to the lake and Temescal Creek, is irrigation at the Regional WRF. The irrigation meter connection is not served from the RW system and is served from the Regional WRF utility water system. Therefore, this service connection is not evaluated as part of this Recycled Water System Master Plan (RWSMP).

7.4.4 Recommendations

There are no recommendations for the Regional system to address existing system deficiencies.

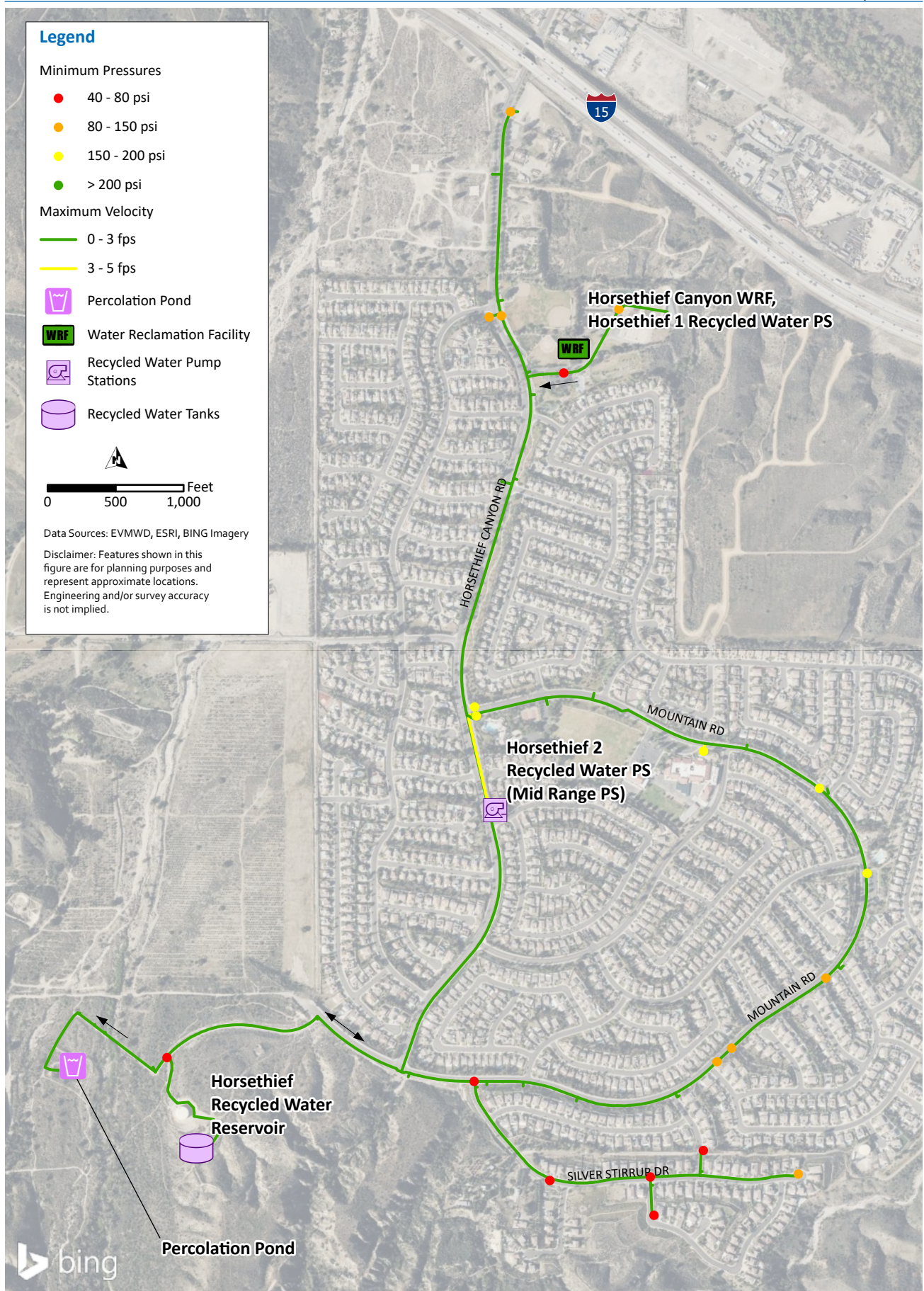

Figure 7.9 Horsethief RW System Pressure and Velocity Results

-This Page Intentionally Left Blank-

7.5 Pipeline and Facility Replacement Plans

Age-based RW pipeline and facility replacement have been reviewed with recommendations for replacement discussed in this subsection.

7.5.1 Pipeline Replacement Plan

The District’s RW system GIS currently has approximately 25.8 miles of RW pipelines. As a full asset-management analysis is beyond the scope of this plan, a desktop level pipeline replacement analysis was conducted along with planning level cost estimates using a number of general planning assumptions.

It was assumed that the average useful life for all pipeline materials is 75 years. Since the oldest pipeline in EVMWD’s RW system was installed in 1995 no pipelines will exceed their useful life until 2060.

As seen on Figure 7.10, no pipeline should require replacement until year 2060, which is beyond the planning horizon of this RWSMP.

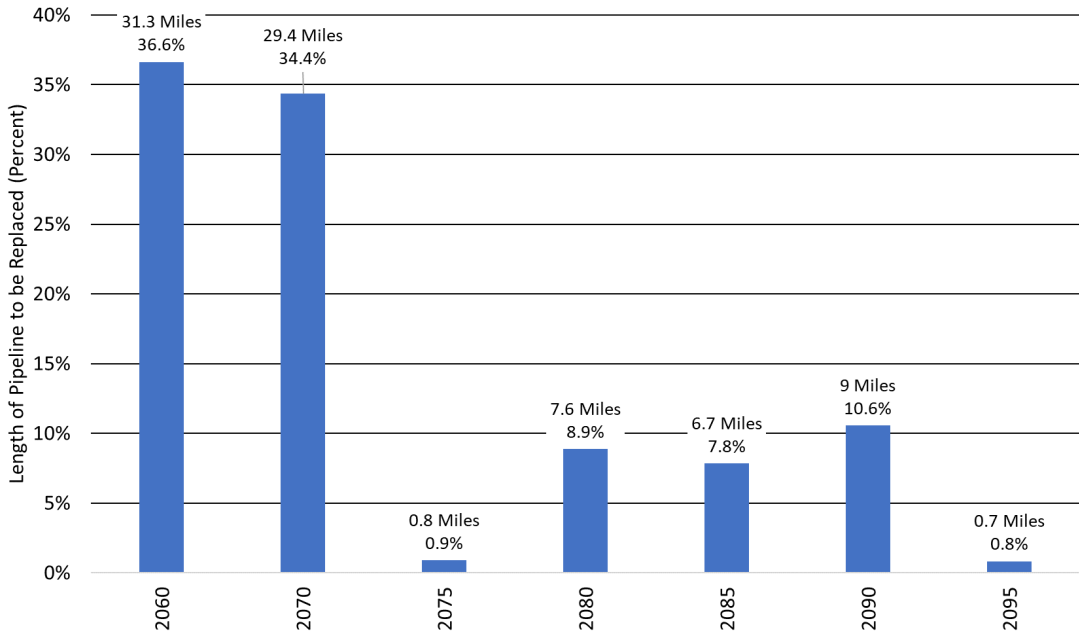

Figure 7.10 Pipeline Replacement by Planning Period

7.5.2 Reservoir Replacement Plan

The existing recycled system consists of 4 reservoirs installed between 1995 and 2003. Based on the 75-year useful life criteria discussed in Chapter 7 for reservoirs, no reservoirs will need to be replaced within the planning horizon. Reservoirs will require continued maintenance.

7.5.3 Pump Replacement Plan

The existing RW system consists of four booster pumping stations, with a total of ten pumps. The pump stations were installed between 1985 and 2003. Using an expected life of 20 years for booster pumps, the pumps are past due for replacement and were recommended to be replaced before 2025. Based on the design life criteria, pumps that are scheduled for replacement between 2023 and 2025 will likely need to be replaced again in the 2040-2045 horizon. Similarly, pumps that are scheduled for replacement between 2025-2030 will likely need to be replaced again in the 2045-2050 horizon. Because each individual booster pump was not given an installation date, the installation date of the entire booster station was used to represent all the pumps within a station. The recommended pump replacements are shown in Table 7.3, which only includes the pumps and motor/electrical equipment but no pump station building and pipeline appurtenances. Because installation dates of individual pumps may differ within a booster station, and individual booster station life depends on many factors besides age, it is important to use these replacement schedules as a general guideline and make replacements based on the physical conditions, hydraulic function, and energy usage of each booster pump.

Table 7.3 Age Based Booster Replacement Recommended Phasing

Pump Name	Installation Year	Number of Pumps	Pump and Motor Replacement Phasing
Cottonwood Hills	2002	3	2023-2025 and 2040-2045
Canyon Hills Golf Course	1985	2	2023-2025 and 2040-2045
Horsethief 1 (at Horsethief Canyon WRF)	2003	3	2025-2030 and 2045-2050
Horsethief 2 (Mid-Range)	1995	3	2023-2025 and 2040-2045

As shown in Table 7.3, the majority of pump stations have pumps that exceeded their useful life. It is impractical for EVMWD to replace all these pumps between 2023-2025, and, therefore, pump efficiency tests should be analyzed every few years to better prioritize the replacement of the booster pumps. It is also recommended that the EVMWD perform a detailed investigation to determine the year of installation and physical condition of the pumps with unknown year of installation before replacing them.

Chapter 8

FUTURE SYSTEM ANALYSIS

This chapter includes the future system analysis for the recycled water (RW) system. As previously described in Chapter 4, Elsinore Valley Municipal Water District's (EVMWD/District) RW system consists of four separate areas that use RW from four separate sources, three of which are owned and operated by EVMWD, Railroad Canyon Water Reclamation Facility (WRF), Horsethief Canyon WRF, and Regional WRF. One system, Wildomar area, receives water primarily from the Temecula Valley Regional WRF, which is owned and operated by Eastern Municipal Water District (EMWD). The Santa Rosa WRF has the ability to provide RW if desired and available.

This chapter is similarly organized by individual RW systems and includes the evaluation of each RW system under future demand conditions. Hydraulic deficiencies based on evaluations are identified and infrastructure improvements are recommended to address the deficiencies.

8.1 Wildomar System Future System Analysis

Potential future non-potable RW demand in the Wildomar area was estimated by analyzing existing potable customers billing data as well as potable water demand projections associated with planned developments near the existing Wildomar RW system. Future demands may come from future planned developments and from existing customers currently being served by potable water that could be served by the RW system. The supply demand analysis, potential future demand, and how the future demand from planned developments was determined are described in more detail in Chapter 3.

Along with potential planned developments, a large potential RW demand is the Back Basin wetlands. The Summerly development is responsible for purchasing water to maintain levels in the Back Basin wetlands for environmental purposes. Currently, there is a pipeline and pump station under construction. If RW is available, and not used for irrigation for the Wildomar system, that water could be sent to the Back Basin if the water levels in the Back Basin wetlands are low. As part of the Summerly Storm Water Pump Station project, the developer is making a connection to the existing RW main near Cereal Street. The new pipeline extends within the pump station site with a flowmeter to measure the RW discharge. The new pipeline further extends along Cereal Street and connects to the existing Island Wells Line. The Island Wells Line has an existing discharge point into the Back Basin. EVMWD

will be able to provide a portion of the Back Basin wetlands demand as the water becomes available as discussed in Chapter 3.

As discussed in Chapter 3, based on a maximum flow from the Temecula Valley Recycled Water Pipeline (TVRWP) of 2 million gallons per day (mgd), all available RW will be used for 9 months a year from March through November after inclusion of Back Basin wetland demands. There will only be flow available in the winter months of December through February. Therefore, unless there are additional water supplies, there are no available supplies for non-potable reuse (NPR) expansion. NPR is the distribution of RW for irrigation, industrial, and other urban purposes.

The following three alternatives are options for the Wildomar system:

- Alternative 1 - No Additional RW Supply. EVMWD would continue serving existing customers, plus the Back Basin wetlands, with water from the TVRWP. There would be no expansion of the Wildomar system since water would only be available during winter months.
- Alternative 2 - Acquisition of Additional RW to Support local Wildomar Expansion. If there is additional water available, EVMWD could choose to implement the NPR projects discussed in this section. If EVMWD were to implement these projects, EVMWD would need to purchase additional capacity in the TVRWP.
- Alternative 3 - Acquisition of Additional RW to Support Regional and Railroad Canyon Area Demand. Alternatively, if there is additional water available in the Wildomar system, the water could be routed to the Railroad Canyon system, with the wastewater currently treated at Railroad Canyon WRF sent to Regional WRF for treatment and use via an indirect potable reuse (IPR) system. The amount of flow routed to the Railroad Canyon WRF would depend on the amount available from Wildomar. If the flow from Wildomar is used for the Back Basin wetlands demand, none would be available for the Railroad Canyon WRF. This concept has not been quantified for the purposes of this master plan.

Alternative 1 is the current recommendation for the Wildomar system. Outside of the winter months, there are no additional RW supplies available to the Wildomar system beyond existing customers and the Back Basin wetlands, both under existing and future conditions based on the maximum flow of 2 mgd available from the TVRWP.

8.1.1 Potential Wildomar System Projects

If EVMWD desires to purchase additional RW for the Wildomar system, the non-potable system can be expanded to include potential planned developments. As described in Chapter 3, there are five potential projects for the Wildomar system.

Potential developments and the infrastructure needed for these projects are shown in this section. These include existing potable water customers that could be served by the RW system.

The potential developments for Wildomar system Project 1, off Clinton Keith Road, and the size and length of pipelines needed to connect these planned developments to the existing system are shown in Table 8.1 and Table 8.2.

Table 8.1 Wildomar Project 1 - Potential Demand Summary

Customers	Estimated Demand (AFY)	Existing Customer or Planned Development	Development Number ⁽¹⁾
Hidden Springs Mixed Use	63	Planned Development	485
Clinton Keith Mt. San Jacinto College Campus	56	Planned Development	128
Rancon Medical and Education Center	23	Planned Development	370
Inland Valley Medical Center	14	Planned Development	369
Horizon Condos Tract 36672	12	Planned Development	53
Hotel at Oak Creek Shopping Center	11	Planned Development	247
Westpark	11	Planned Development	73
Oak Springs Ranch Phase 2	11	Existing Potable Customer	-
Santa Rosa Apartments	10	Existing Potable Customer	-
Prielipp Apartments	8	Planned Development	233
Grove Park	7	Planned Development	65
Oak Springs Ranch Phase 2	7	Planned Development	264
Villa Siena	5	Planned Development	58
Total	238		

Notes:

Abbreviations: AFY - acre-feet per year.

(1) Complete list of planned developments tracked by EVMWD is listed in Appendix C.

Table 8.2 Wildomar Project 1 - Size and Length of Pipelines

Diameter (Inch)	Length (Feet)
4	13,941
6	2,068
8	7,950
Total	23,960

The potential developments for Wildomar system Project 2, off Wildomar Trail, and the size and length of pipelines needed to connect these planned developments to the existing system are shown in Table 8.3 and Table 8.4.

Table 8.3 Wildomar Project 2 - Demand Summary

Customer	Estimated Demand (AFY)	Existing Customer or Planned Development	Development Number
Baxter Village	14	Planned Development	66
Baxter Road and I-15 Mixed Use Project	9	Planned Development	216
Total	23		

Table 8.4 Wildomar Project 2 - Size and Length of Pipelines

Diameter (Inch)	Length (Feet)
4	2,467
Total	2,467

The potential developments for Wildomar system Project 3, off Orange Street, and the size and length of pipelines needed to connect these planned developments to the existing system are shown in Table 8.5 and Table 8.6.

Table 8.5 Wildomar Project 3 - Demand Summary

Customer	Estimated Demand (AFY)	Existing Customer or Planned Development	Development Number
Orange Street Water and Sewer Improvements	8	Planned Development	63
Total	8		

Table 8.6 Wildomar Project 3 - Size and Length of Pipelines

Diameter (Inch)	Length (Feet)
4	314
Total	314

The potential developments for Wildomar system Project 4, off Corydon Street, and the size and length of pipelines needed to connect these planned developments to the existing system. are shown in Table 8.7 and Table 8.8.

Table 8.7 Wildomar Project 4 - Demand Summary

Customer	Estimated Demand (AFY)	Existing Customer or Planned Development	Development Number
Won Meditation/Retreat Center	17	Planned Development	270
94 Unit Apartments on Corydon Road and Sheets Lane	11	Planned Development	152
Corydon Road and Grand Avenue Mixed Use - APN 370-171-015	6	Planned Development	445
Total	34		

Table 8.8 Wildomar Project 4 - Size and Length of Pipelines

Diameter (Inch)	Length (Feet)
4	9,270
6	2,270
Total	11,540

The potential developments for Wildomar system Project 5, off Diamond Drive, and the size and length of pipelines needed to connect these planned developments to the existing system are shown in Table 8.9 and Table 8.10.

Table 8.9 Wildomar Project 5 - Demand Summary

Customer	Estimated Demand (AFY)	Existing Customer or Planned Development	Development Number
Lake Elsinore Commerce Center	66	Planned Development	314
Canyon Hills Phase 7 Landscape	20	Planned Development	293
Greenspring Hotel	10	Planned Development	187
Artisan Alley	9	Planned Development	181
Lake Elsinore Motorsports Park	8	Existing Potable Customer	-
River's Edge Apartment	6	Existing Potable Customer	-
Econo Lodge Lake Elsinore Casino	5	Existing Potable Customer	-
Total	124		

Table 8.10 Wildomar Project 5 - Size and Length of Pipelines

Diameter (Inch)	Length (Feet)
4	7,054
Total	7,054

8.1.2 Required Booster Pump Capacity

If EVMWD were to expand the system, EVMWD will need to purchase additional capacity in TVRWP to meet peak hour demands. Another alternative is to only purchase capacity in the TVRWP for maximum day demands; if, the District decides to pursue NPR expansion, they would need to construct storage for the Wildomar system, plus booster pumps, depending on the location of the storage reservoir. It is not recommended that EVMWD construct storage and booster pumps for the Wildomar system.

8.1.3 Required Storage Capacity

The total average day demand (ADD) for the proposed Wildomar system expansion are 0.4 mgd. Using the maximum day demand (MDD) peaking factor (PF) of 2.95 from the Wildomar Turnout No. 1 diurnal curve, the MDD is 1.18 mgd. Using planning PF of 2.7, the peak hour demands (PHD) for the expansion would be 3.2 mgd. Building a large volume of storage for the Wildomar system would provide minimal benefit. Therefore, it is recommended that EVMWD purchase an additional capacity of 3.2 mgd in TVRWP to meet PHD if potential Wildomar system expansion is pursued.

8.1.4 Required Pipelines

For the Wildomar system, the pipelines needed for a potential expansion of the RW system are shown on Figure 8.1.

The pipelines needed for each potential RW project in the Wildomar system, including the total demand for each project, are shown in Table 8.11 with a summary in Table 8.12.

Table 8.11 Wildomar Potential Projects - Size and Length of Pipelines by Project

Wildomar Project	Total Demand (AFY)	Diameter (Inch)	Length (Feet)
Project 1	238	4	13,941
		6	2,068
		8	7,950
Project 2	23	4	2,467
Project 3	8	4	314
Project 4	17	4	9,270
		6	2,270
Project 5	124	4	7,054
Total	410		45,334

Table 8.12 Wildomar Potential Projects - Size and Length of Pipelines Summary

Diameter (Inch)	Length (Feet)
4	33,046
6	4,338
8	7,950
Total	45,334

The cost to expand the RW system in the Wildomar area if water is available is presented in Chapter 9.

8.1.5 Recommendations

Currently, there are no additional supplies available in the Wildomar system for additional use. No expansion of the Wildomar system is recommended other than the connection of the Back Basin wetlands as a RW customer.

8.2 Railroad Canyon System Future System Analysis

The Railroad Canyon system currently has more RW demand than supply from the Railroad Canyon WRF. The system already depends on supplemental purchased RW from EMWD and supplement from EVMWD's potable water system. As there are no plans to expand Railroad Canyon WRF, additional water is not available to supply to additional RW customers.

8.2.1 Potential Recycled Water Customer

There is only one potential future RW user identified in the Railroad Canyon service area. A single development (Railroad Canyon Mixed-Use) with the potential demand of 8 AFY.

8.2.2 Required Booster Pump Capacity

Since there is minimal potential for future demands, additional booster pump capacity is not necessary to meet future demands.

8.2.3 Required Storage Capacity Evaluation

Since there is minimal potential for future demands, additional storage capacity is not necessary to meet future demands.

8.2.4 Required Pipelines

Since there is minimal potential for future demands, there is adequate capacity to accommodate this increase, and additional pipelines are not necessary to meet future demands.

8.2.5 Recommendations

Since the existing available RW supplies in the Railroad Canyon area are already used and there is minimal potential for future demands, there are no recommendations for expansion of the Railroad Canyon system.

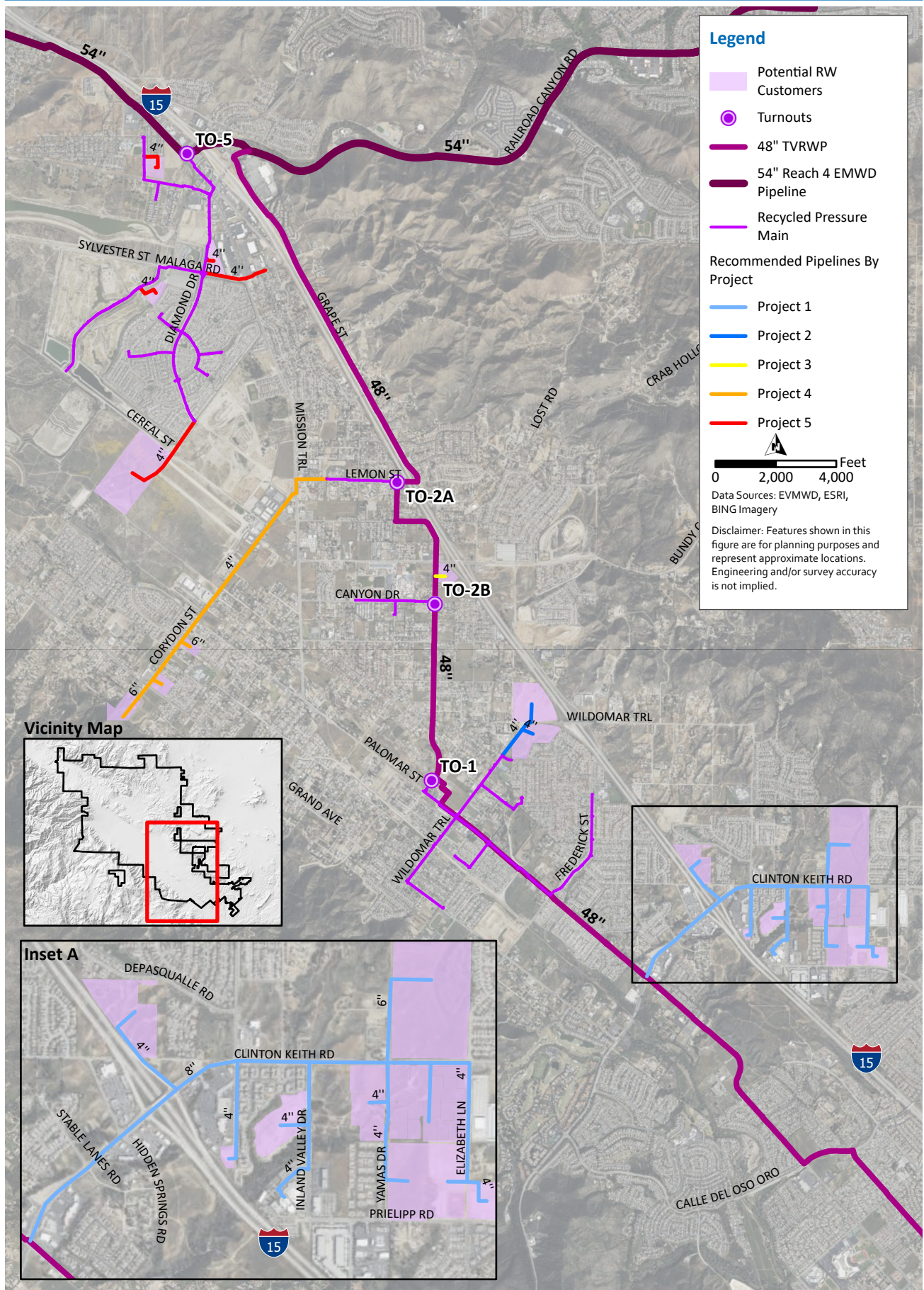

Figure 8.1 Wildomar Recommended Pipelines

-This Page Intentionally Left Blank-

8.3 Horsethief System Future System Analysis

Using the same methodology as the Wildomar system, potential future RW customers were identified for the Horsethief System.

8.3.1 Potential Recycled Water Projects

Planned developments were identified for the mid-term and long-term. Four developments (Renaissance Ranch, JBJ Ranch, Saddleback Estates, and SAM) were identified as mid-term developments with a total future demand of 128 AFY and two (Sycamore Creek Marketplace and Horsethief Ridge Tract 37002) developments were identified as long-term developments with a total future demand of 145 AFY. The mid-term developments are expected to be constructed by 2030. Note that this analysis assumes that Renaissance Ranch is a residential development, based on current land use, but if Renaissance Ranch becomes a commercial development, the RW needs will be decreased. The demands are listed in Table 8.13.

Table 8.13 Future Horsethief RW Demands

Customer	Estimated Demand (AFY)	Timing	Development Number
Renaissance Ranch Commerce Center	20	Mid-Term	330
JBJ Ranch	51	Mid-Term	8
Saddleback Estates	48	Mid-Term	6
SAM	9	Mid-Term	230
Sycamore Creek Marketplace	9	Long-Term	305
Horsethief Ridge Tract 37002	8	Long-Term	457
Total	145	Varies	

8.3.2 Required Booster Pump Capacity

The Horsethief Canyon System has five booster pumps at two locations. There are two pumps at the Horsethief 1 Pump Station which pump from the Horsethief WRF to the 1518 Zone. The other three pumps are at the Horsethief 2 (Mid-Range Pump Station [MRPS]) Pump Station, which pump from 1518 Zone to 1844 Zone.

As described in Chapter 7, the existing analysis showed that there is insufficient firm capacity to deliver the MDD at the Horsethief 1 pump station and an additional parallel pump will be required. The future analysis is performed for mid-term and long-term for both the pump stations of this system and does not assume that existing deficiency listed in Chapter 7 has been mitigated.

8.3.2.1 Mid-Term Required Pump Capacity Analysis

At Horsethief 1 Pump Station, for the mid-term, the average dry weather flow (ADWF) is 389 gallons per minute (gpm) compared to a firm capacity of 295 gpm. The Horsethief 1 Pump Station needs to be able to pump ADWF for all flows into the

Horsethief WRF for disposal, MDD for the entire Horsethief system to meet demands, and PHD for the 1518 Zone since there is insufficient storage capacity in the 1518 Zone (discussed later). The required flows for these three conditions are 389 gpm for ADWF, 594 gpm for MDD of the Horsethief system, and 519 gpm for PHD of the 1518 Zone. As a result, the pumps at Horsethief 1 Pump Station are deficient in delivering all three of these conditions by 94 gpm, 299 gpm and 223 gpm, respectively. The new parallel pump with a capacity of 327 gpm already included in the recommendations in Chapter 7 will be sufficient to address this deficiency.

At Horsethief 2 Pump Station, for the mid-term, the ADWF is 389 gpm compared to a firm capacity of 690 gpm. The MDD is 390 gpm. The Horsethief 2 Pump Station needs to be able to pump ADWF for all flows into the Horsethief WRF for disposal and MDD for the 1844 Zone. As a result, there is excess capacity for the pumps at Horsethief 2 Pump Station in delivering the ADWF and MDD. Hence, no additional pump is required to be able to deliver the required demands for the 1844 Zone.

The mid-term analysis is shown in Table 8.14.

8.3.2.2 Long-Term Required Pump Capacity

At Horsethief 1 Pump Station, for the long-term, the average daily supply is 451 gpm compared to a firm capacity of 295 gpm. The Horsethief 1 Pump Station needs to be able to pump ADWF for all flows from the Horsethief WRF for disposal, MDD for the entire Horsethief system to meet demands, and PHD for the 1518 Zone since there is insufficient storage capacity in the 1518 Zone (discussed later). The required flow for these three conditions is 451 gpm for ADWF, 622 gpm for MDD of the Horsethief system, and 590 gpm for PHD of the 1518 Zone. As a result, the pumps at Horsethief 1 Pump Station are deficient in delivering the ADWF, MDD, and the PHD by 156 gpm, 327 gpm, and 295 gpm, respectively. The new parallel pump with a capacity of 327 gpm already included in the recommendations in Chapter 7 will be sufficient to address this deficiency.

At Horsethief 2 Pump Station, for the long-term, the ADWF is 451 gpm compared to a firm capacity of 690 gpm. The MDD is 390 gpm. The Horsethief 2 Pump Station needs to be able to pump ADWF for all flows into the Horsethief WRF for disposal and MDD for the 1844 Zone. As a result, there is excess capacity for the pumps at Horsethief 2 Pump Station in delivering the ADWF and MDD. Hence, no additional pump is required to be able to deliver the required demands for the 1844 Zone.

The long-term analysis is shown in Table 8.15.

Table 8.14 Mid-Term Booster Pump Station Analysis for Horsethief System

Pump Station	2030 (Mid-Term)							Additional Capacity Required
	Average Supply (gpm)	Firm Capacity (gpm)	MDD ⁽¹⁾ (gpm)	PHD (gpm)	ADWF Pump Surplus/Deficit (gpm)	MDD Pump Surplus/Deficit (gpm)	PHD Pump Surplus/Deficit (gpm)	
Horsethief 1 (1518 Zone)	389	295	594 ⁽²⁾	519 ⁽³⁾	-122	-299	-223	Additional Pump Required at Horsethief 1 Pump Station
Horsethief 2 (MRPS) (1844 Zone)	389	690	390	-	364	300	-	Not Required

Notes:

- (1) Supplemental water is needed for MDD when the demand is greater than the supply for some months in the year.
- (2) This is the MDD of the entire Horsethief system, which needs to be pumped through the Horsethief 1 Pump Station.
- (3) This is the PHD of the 1518 Zone.

Table 8.15 Long-Term Booster Pump Station Analysis for Horsethief System

Pump Station	2050 (Long-Term)							Additional Capacity Required
	Average Supply (gpm)	Firm Capacity (gpm)	MDD ⁽¹⁾ (gpm)	PHD (gpm)	ADWF Pump Surplus/Deficit (gpm)	MDD Pump Surplus/Deficit (gpm)	PHD Pump Surplus/Deficit (gpm)	
Horsethief 1 (1518 Zone)	451	295	622 ⁽²⁾	590 ⁽³⁾	-156	-327	-295	Additional Pump Required at Horsethief 1 Pump Station
Horsethief 2 (MRPS) (1844 Zone)	451	690	390	-	253	300	-	Not Required

Notes:

- (1) Supplemental water is needed for MDD when the demand is greater than the supply for some months in the year.
- (2) This is the MDD of the entire Horsethief system, which needs to be pumped through the Horsethief 1 Pump Station.
- (3) This is the PHD of the 1518 Zone.

8.3.3 Required Storage Capacity

For the Horsethief system, the storage analysis was performed for the mid-term and long-term scenarios for the Horsethief Canyon WRF, 1518 Zone and the 1844 Zone. The total storage was calculated as the amount of storage needed based on the supply and the hourly MDD and 20 percent was added to account for emergency or dead storage.

8.3.3.1 Mid-Term Storage - Horsethief Canyon WRF

The mid-term total storage needed for the Horsethief Canyon WRF is 152,000 gallons as shown on Figure 8.2. This includes storage needed based on the required supply and the hourly MDD and 20 percent for emergency or dead storage. The total demand is calculated as the sum of demands from 1518 Zone and the 1844 Zone. The supply available for each hour is calculated by multiplying the demand for that hour by the hourly factor from the diurnal curve for Horsethief Canyon WRF. The available storage is 333,000 gallons, and there is a 181,000 gallons surplus for the Horsethief Canyon WRF in the near-term.

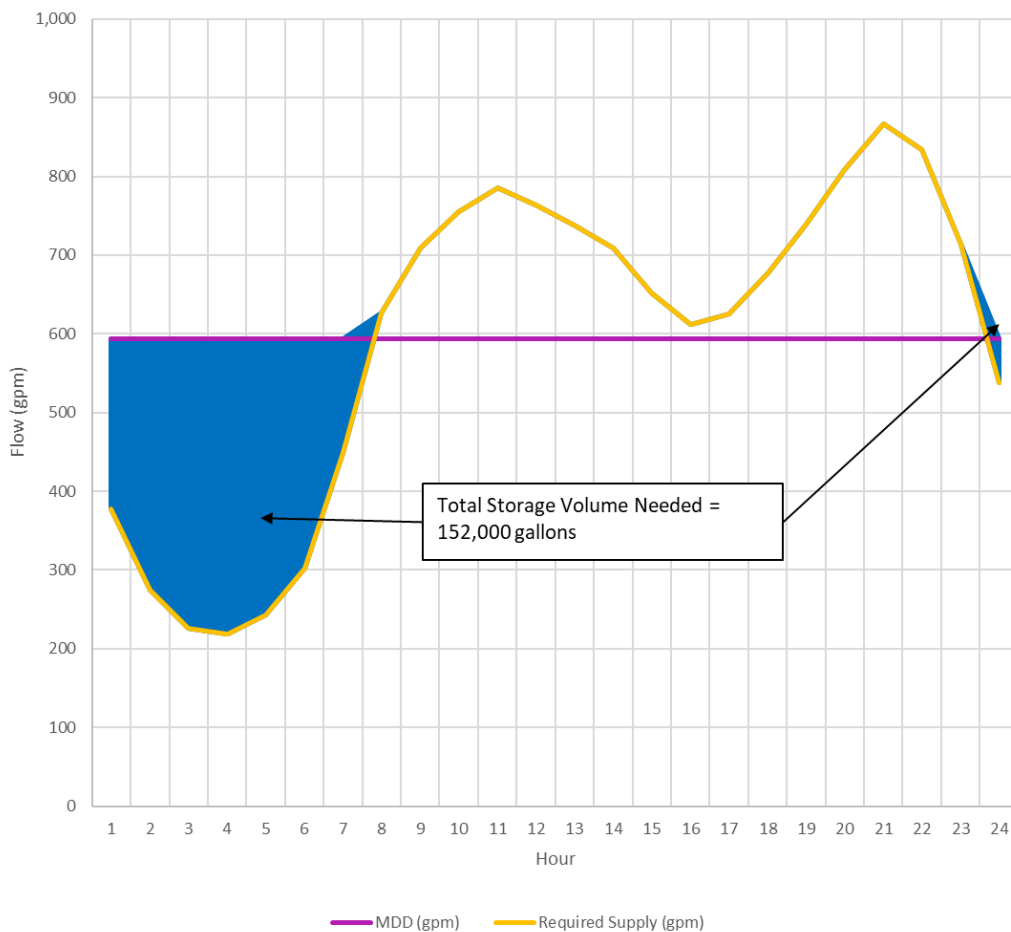

Figure 8.2 Horsethief Canyon WRF Mid-Term Storage Needs

8.3.3.2 Mid-Term Storage 1518 Zone

The mid-term storage needed for the 1518 Zone is 124,000 gallons as shown on Figure 8.3. This includes storage needed based on the required supply and the hourly MDD and 20 percent for emergency or dead storage. The supply for the 1518 Zone is assumed to be the existing MDD for the zone, which is 203 gpm. This supply was multiplied by the hourly diurnal pattern factors to calculate the hourly demand. The available storage is 50,000 gallons and there is a 74,000 gallons deficiency for the 1518 Zone in the near-term. This deficiency will be supplied from the Horsethief Canyon WRF and hence no storage tank is proposed for the 1518 Zone.

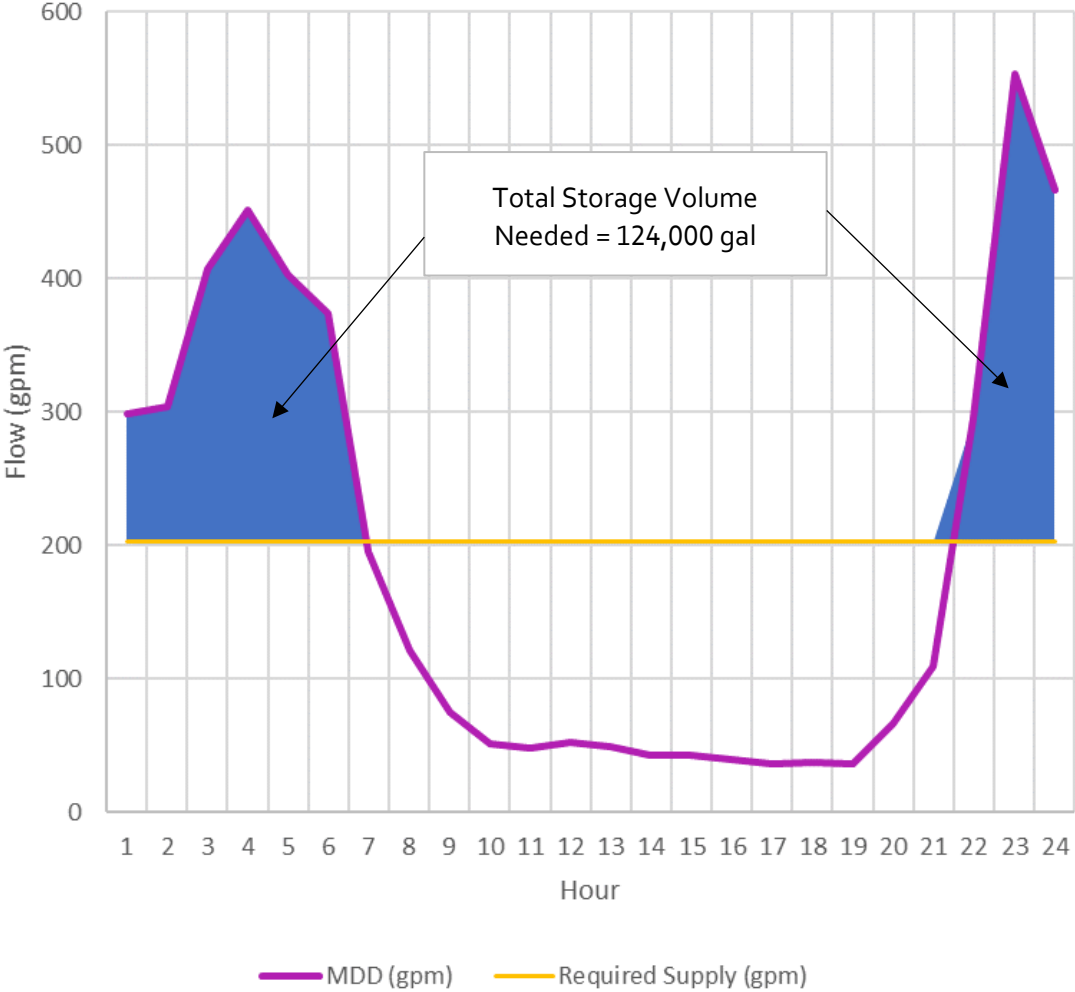

Figure 8.3 1518 Zone Mid-Term Storage Needs

8.3.3.3 Mid-Term Storage 1844 Zone

The near-term storage needed for the 1844 Zone is 238,000 gallons as shown on Figure 8.4. This includes storage needed based on the required supply and the hourly MDD and the 20 percent for emergency or dead storage. The supply for the 1844 Zone is assumed to be the existing MDD for the zone, which is 390 gpm. This supply was multiplied by the hourly diurnal pattern factors to calculate the hourly demand. The available storage is 170,000 gallons and there is a 68,000 gallons deficiency for the 1844 Zone in the near-term. A storage tank with 68,000 gallons capacity is proposed to be built to mitigate this deficiency.

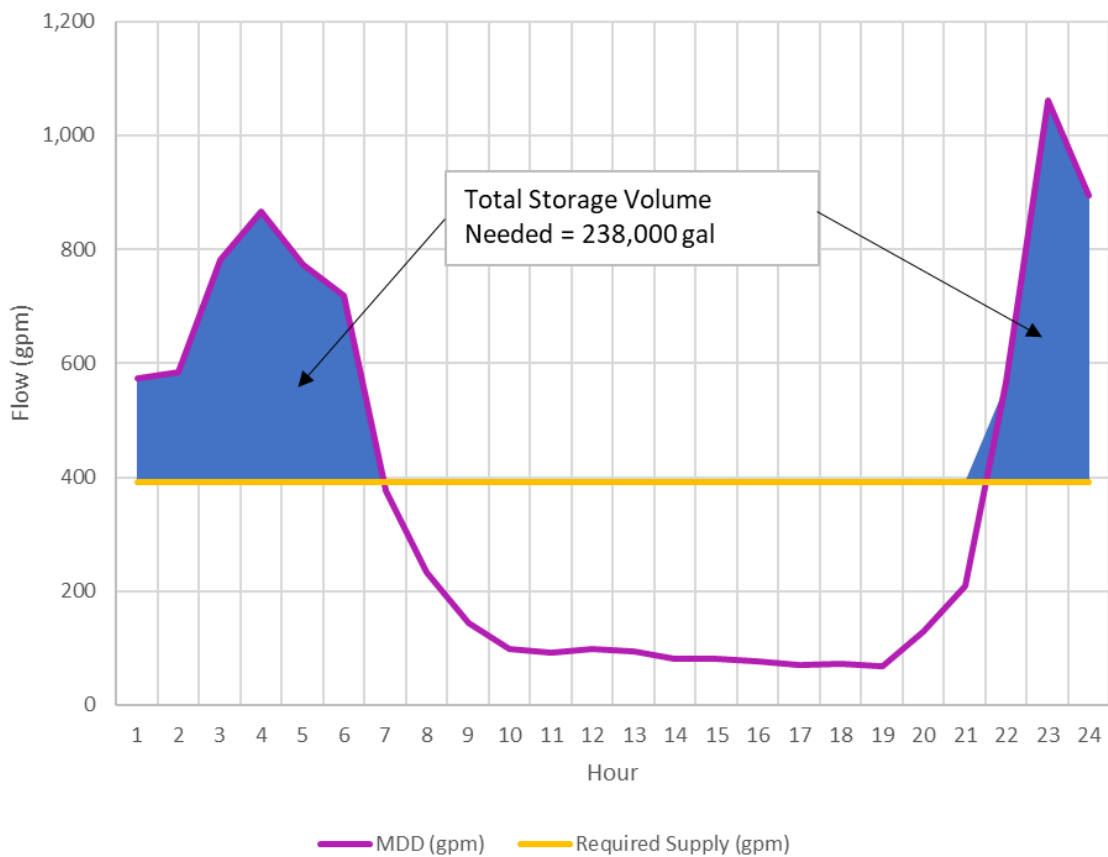

Figure 8.4 1844 Zone Mid-Term Storage Needs

8.3.3.4 Long-Term Storage - Horsethief Canyon WRF

The long-term storage needed for the Horsethief Canyon WRF is 159,000 gallons as shown on Figure 8.5. This includes storage needed based on the required supply and the hourly MDD and 20 percent for emergency or dead storage. The long-term storage for Horsethief Canyon WRF is calculated using the same approach as the near-term storage. The available storage is 333,000 gallons and there is a 174,000 gallons surplus for the Horsethief Canyon WRF in the long-term.

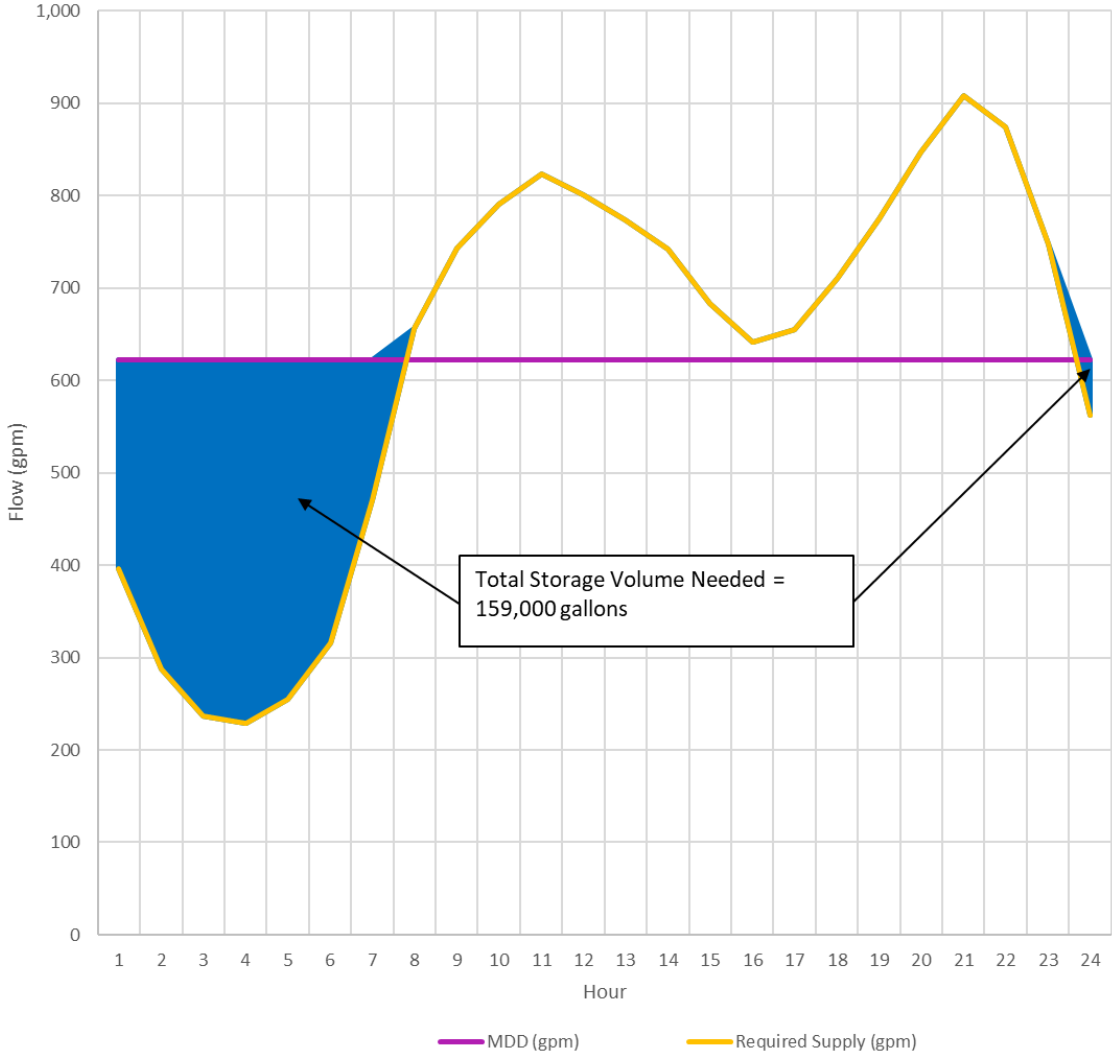

Figure 8.5 Horsethief Canyon WRF Long-Term Storage Needs

8.3.3.5 Long-Term Storage 1518 Zone

The long-term storage needed for the 1518 Zone is 141,000 gallons as shown on Figure 8.6. This includes storage needed based on the required supply and the hourly MDD and 20 percent for emergency or dead storage. The long-term storage for the 1518 Zone is calculated using the same approach as the near-term storage. The

available storage is 50,000 gallons and there is a 91,000 gallons deficiency for the 1518 Zone in the long-term. This deficiency will be supplied from the Horsethief Canyon WRF and hence no storage tank is proposed for the 1518 Zone.

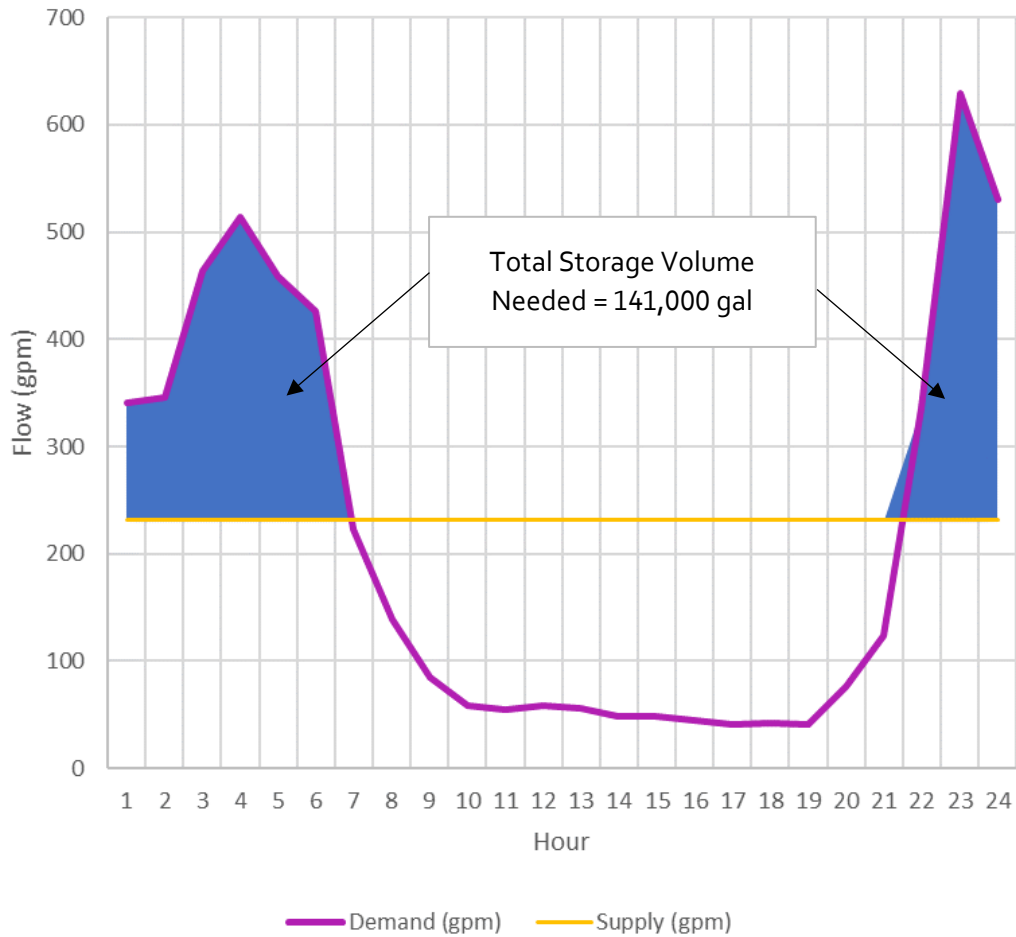

Figure 8.6 1518 Zone Long-Term Storage Needs

8.3.3.6 Long-Term Storage 1844 Zone

As there are no additional long-term demands in the 1844 Zone, there is no change between mid-term and long-term storage needs.

8.3.4 Required Transmission Pipelines

For the Horsethief system, the transmission pipelines needed for the expansion of the RW system are shown on Figure 8.7.

The pipelines needed for each potential RW customer in the Horsethief system are shown in Table 8.16.

Table 8.16 Horsethief Required Pipelines

Customer	Diameter (Inch)	Length (Feet)
Renaissance Ranch Commerce Center	4	3,019
JBJ Ranch	6	3,938
Saddleback Estates	6	1,306
SAM	4	554
Sycamore Creek Marketplace	4	4,743
Horsethief Ridge Tract 37002	4	685
Total	Varies	14,245

8.3.5 Recommendations

The recommendation for Horsethief system is to install the new pipes as shown on Figure 8.7. A new parallel pump with a capacity of 327 gpm is required to be able to deliver the required demands for the 1518 Zone. A storage tank with 68,000 gallons capacity is recommended to be built to meet the storage requirements of the 1844 Zone.

8.4 Regional System Future System Analysis

EVMWD owns and operates the Regional WRF which has a nominal average design capacity of 8.0 mgd and is currently undergoing an expansion to 12 mgd. EVMWD is required to discharge a minimum of 0.5 mgd to the Temescal Creek to maintain downstream riparian habitat. Generally, the remaining flows are discharged to Lake Elsinore to maintain the Lake Level at an elevation of 1,240 feet based on the District's agreement with the City of Lake Elsinore.

8.4.1 Potential Regional System Projects

The projected flow from the Regional WRF ranges from 6.05 mgd in 2020 to 13.61 mgd in 2050. The flow from the Regional WRF is dedicated to the Temescal Creek environmental allocation (0.5 mgd) and surface water augmentation in Lake Elsinore to maintain the Lake Level at an elevation of 1,240 feet. Currently, there is no excess water available for any other projects. The projected flow from Regional WRF is expected to reach above 8 mgd by approximately year 2028 as shown on Figure 8.8. Once excess water is available it can be used for reuse, either potable reuse or NPR for future planned developments. There are three potential potable

reuse options: groundwater augmentation, surface water augmentation, or direct potable reuse (DPR).

8.4.2 Potable Reuse

EVMWD performed a study titled Indirect Potable Reuse Feasibility Study in 2017 under its Water Reclamation and Reuse (Title XVI) Program to assess the feasibility of an IPR project by developing and analyzing alternatives using multiple evaluation criteria and providing a project recommendation. A potable reuse project will use the excess RW that will be available after all obligations are fulfilled.

8.4.2.1 Groundwater Augmentation

The first potential potable reuse project is a groundwater augmentation project (IPR) which would provide additional potable water supply, storage in the Elsinore Groundwater Subbasin (Back Basin area). IPR via groundwater augmentation will help increase EVMWD's potable water supply, reduce dependence on imported water, and diversify the water supply portfolio. This project would also give credit for salt removal from wastewater which would benefit groundwater quality in the Elsinore Valley Subbasin.

The groundwater augmentation project would construct advanced treatment at Regional WRF, a new transmission pipeline, and five new injection wells for the IPR project as shown on Figure 8.9. The project is divided into two phases, with the first phase with a capacity of 3.0 mgd and the second phase with additional capacity of 3.0 mgd. Three wells would be constructed in the 2030-2035 time period with the remaining two wells to be constructed in the 2035-2040 time period.

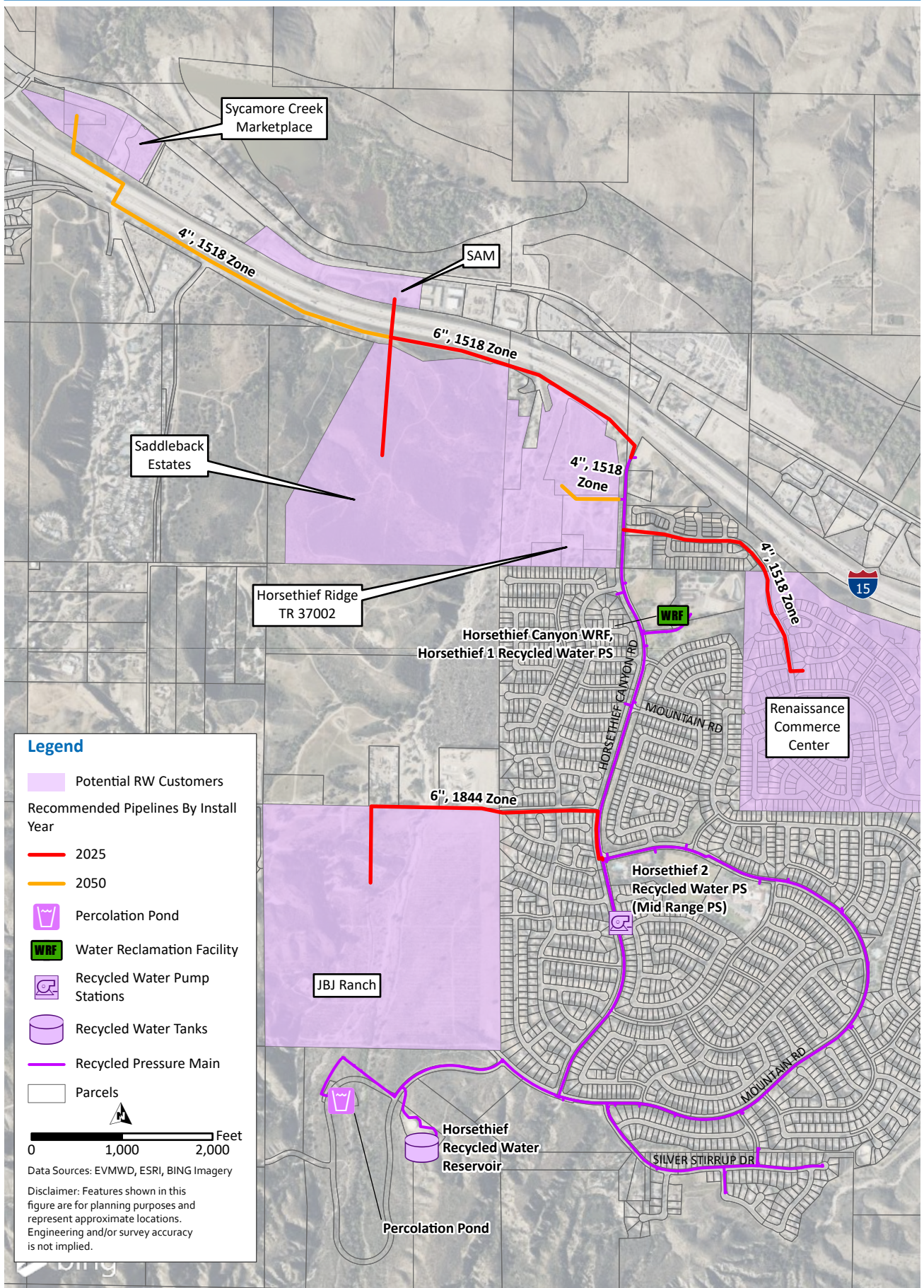

Figure 8.7 Horsethief Recommended Pipelines

-This Page Intentionally Left Blank-

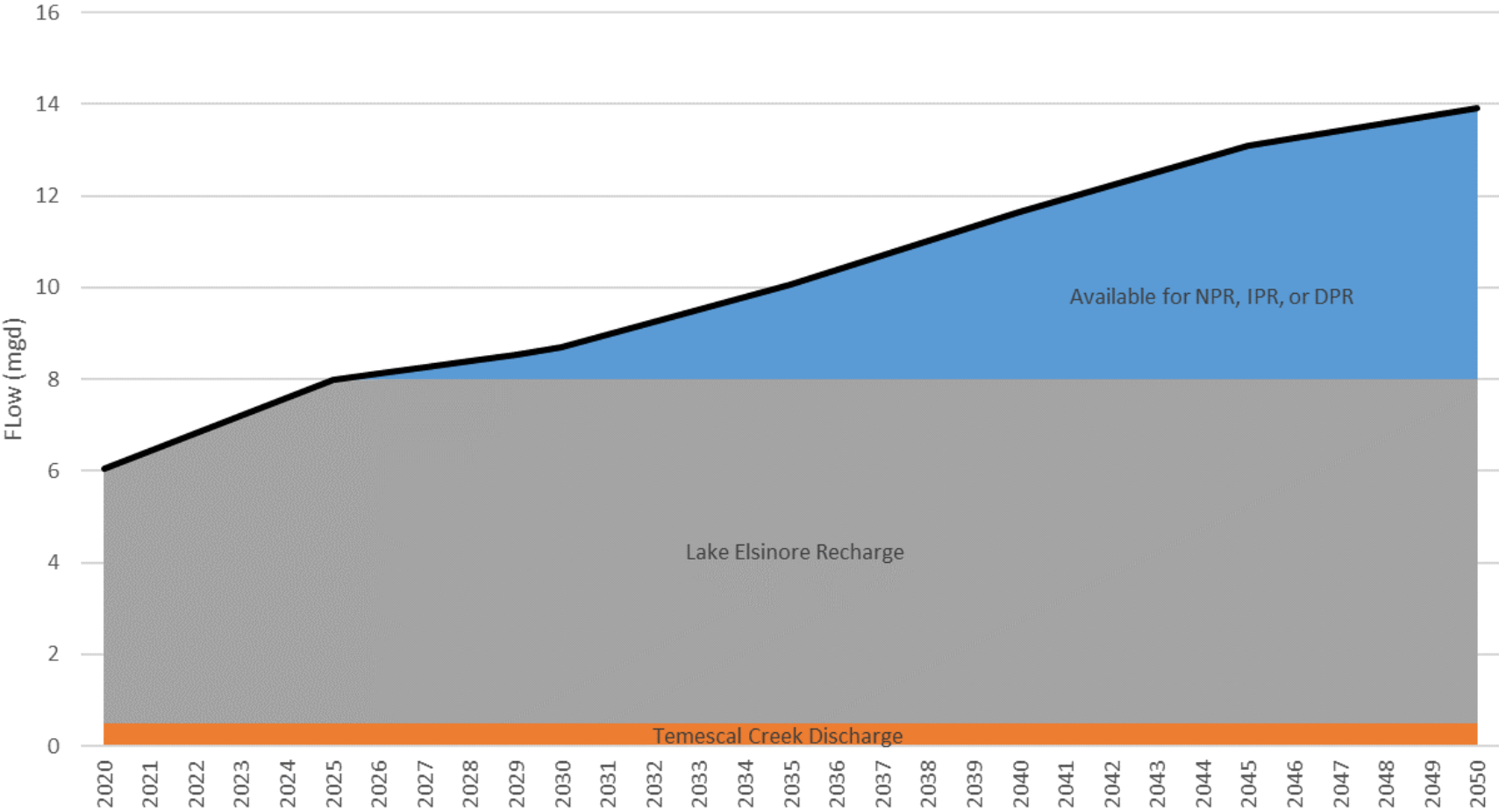

Figure 8.8 Regional Supply Availability for IPR or NPR Projects

-This Page Intentionally Left Blank-



Figure 8.9 Proposed Groundwater Augmentation System

-This Page Intentionally Left Blank-

8.4.2.2 Surface Water Augmentation

The second potential potable reuse project is a surface water augmentation project (IPR) which would convey advanced-treated water from the Regional WRF for surface water storage in Canyon Lake. This project would provide additional potable water supply, with the flows treated at Canyon Lake WTP prior to delivery to the potable water system. This project would also give credit for salt removal from wastewater which would benefit groundwater quality in the Elsinore Valley Subbasin. This project is shown on Figure 8.10.

8.4.2.3 Direct Potable Reuse

The third potential potable reuse project is the installation of a DPR facility at the Regional WRF. The California State Water Resources Control Board is expected to approve DPR regulations in fall 2023.

8.4.3 Non-Potable Reuse

If the IPR or DPR projects are not implemented, the excess water available from the Regional WRF could be utilized to provide non-potable water to future planned customers. There are three potential projects for the Regional system.

Potential developments and the infrastructure needed for these projects are shown in this section. These include existing potable water customers that could be served by the RW system. Regional Project 1 would serve the 3rd Street and the Rosetta Canyon areas, with demands listed in Table 8.17. Regional Project 2 would serve the Elsinore Valley Cemetery and Alberhill with demands listed in Table 8.18. Regional Project 3 would serve Riverside Drive with demands listed in Table 8.19.

Table 8.17 **Regional Project 1 - Potential Demands**

Customer	Estimated Demand (AFY)	Existing Customer or Planned Development	Development Number
The Cove Apartments	51	Planned Development	475
Walmart Shopping Center, Inc.	14	Planned Development	110
Highway 74 Contractor Yard	12	Planned Development	455
La Quinta Hotel on Dexter Avenue	7	Planned Development	151
Central Grocery and Retail	7	Planned Development	402
Collier Honda Dealership	6	Planned Development	215
Lake Elsinore Commercial	5	Planned Development	314
Rosetta Canyon	27	Existing Potable Customer	-
Total	112		

Table 8.18 Regional Project 2 - Potential Demands

Customer	Estimated Demand (AFY)	Existing Customer or Planned Development	Development Number
Hoist Industrial	17	Planned Development	97
Marriott Hotel	15	Planned Development	238
Nichols Industrial Center	12	Planned Development	364
Alberhill Ranch	341	Planned Development	375
Elsinore Valley Cemetery	55 ⁽¹⁾	Existing, Currently Using Private Well	-
Total	440		

Notes:

(1) Demand based on historical existing cemetery pumping data reported in the Elsinore Valley Sub-basin Groundwater Sustainability Plan.

Table 8.19 Regional Project 3 - Potential Demands

Customer	Estimated Demand (AFY)	Existing Customer or Planned Development	Development Number
La Laguna RV Residential Lot	175	Planned Development	192
Lakeside Pointe Apartments	17	Planned Development	358
Lakeview Manor	12	Planned Development	185
Riverside Drive Lake Front Hotel - Mixed Use	11	Planned Development	170
Total	361		

8.4.3.1 Required Booster Pump Capacity

Three booster pump stations will be required for a potential Regional NPR system. The three pump stations are listed in Table 8.20 and shown on Figure 8.11. The pump stations are sized for peak hour demands, as all the proposed storage will be at the Regional WRF.

Table 8.20 Booster Pump Stations for Regional NPR System

Area Served	Approximate Location	Suction Pressure Zone	Discharge Pressure Zone	Flow (gpm)	Total Dynamic Head (Feet)
3rd Street	Regional WRF	WRF	1550	3,800	280
Rosetta Canyon	Along 3rd Street northeast on Conrad Avenue	1550	1700	400	175
Nichols Road/Alberhill	Baker Street Tank	1550	1800	2,000	385

8.4.3.2 Required Storage Capacity

Storage would be required for a Regional NPR system. The storage would need to be 0.6 million gallons (MG), including 20 percent dead storage if all three NPR projects described earlier are constructed. The storage would most likely be gravity storage located at the Regional WRF as shown on Figure 8.10.

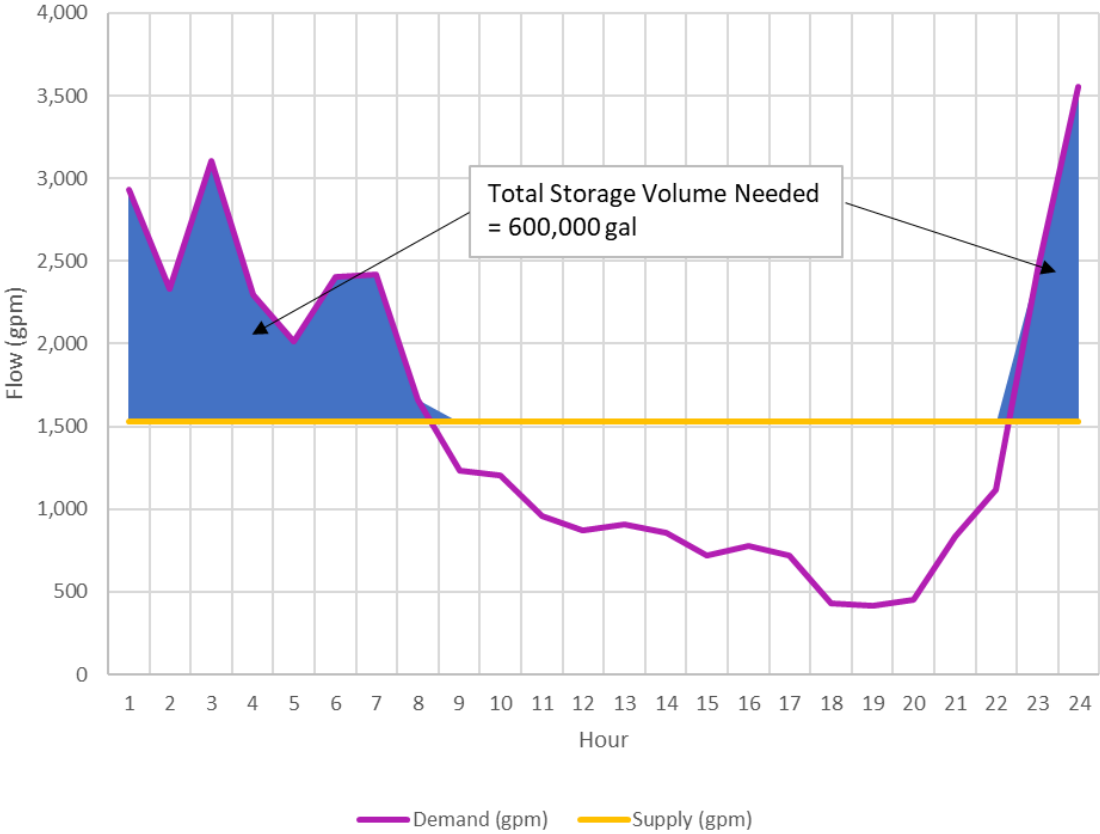

Figure 8.10 Regional Storage Needs for Potential Projects

8.4.3.3 Required Pipelines

The pipelines needed for a potential Regional NPR system are shown on Figure 8.11. The pipelines needed for each potential NPR project in the Regional system are shown in Table 8.21, Table 8.22, and Table 8.23. A summary of the pipelines is shown in Table 8.24.

Table 8.21 Regional Project 1 - Size and Length of Pipelines

Diameter (Inch)	Length (Feet)
6	7,177
20	3,162
24	2,636
Total	13,075

Table 8.22 Regional Project 2 - Size and Length of Pipelines

Diameter (Inch)	Length (Feet)
6	794
12	18,136
16	5,864
Total	24,794

Table 8.23 Regional Project 3 - Size and Length of Pipelines

Diameter (Inch)	Length (Feet)
6	9,250
12	9,281
Total	18,531

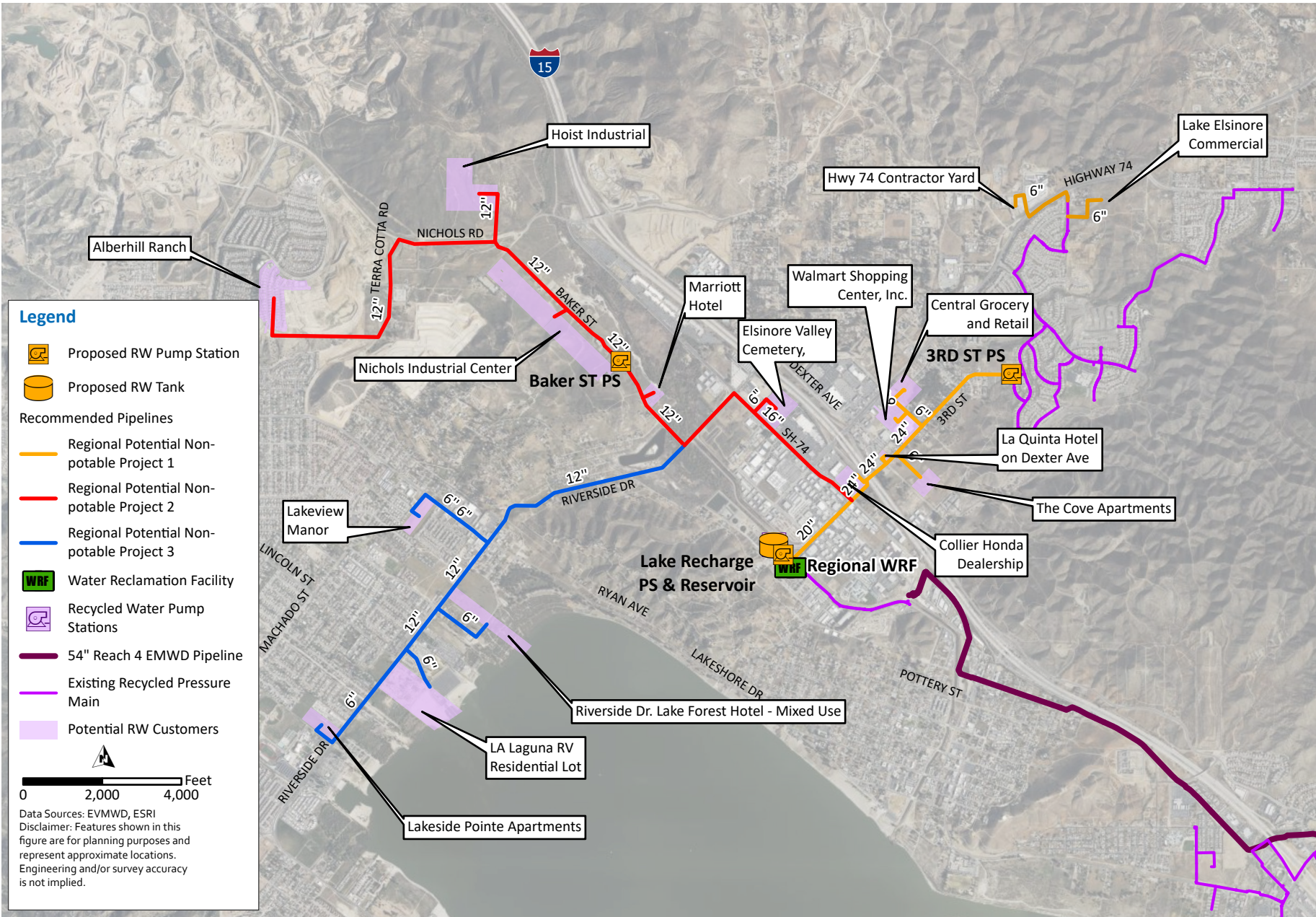

Figure 8.11 Regional Recommended Pipelines

-This Page Intentionally Left Blank-

The pipelines needed for each potential RW project in the Regional system, including the total demand for each project, are shown in Table 8.24 with a summary in Table 8.25.

Table 8.24 Regional Potential Projects - Size and Length of Pipelines by Project

Regional Project	Total Demand (AFY)	Diameter (Inch)	Length (Feet)
Project 1	112	6	7,177
		20	3,162
		24	2,636
Project 2	440	6	794
		12	18,136
		16	5,864
Project 3	361	6	9,250
		12	9,281
Total	1,818		56,300

Table 8.25 Regional Potential Projects - Size and Length of Pipelines

Diameter (Inch)	Length (Feet)
6	17,221
12	27,417
16	5,864
20	3,162
24	2,636
Total	56,300

The cost to create a Regional NPR is discussed in Chapter 9 if water is available.

8.4.4 Recommendations

For budgetary purposes, the groundwater augmentation project recharging advanced-treated water into the Back Basin has been included in this Recycled Water System Master Plan (RWSMP). The District will need to evaluate the various potable reuse options further to determine the best potable reuse option for the District. The potable reuse project will be possible when flow rates are above 8 mgd at the Regional WRF.

If for some reason, there is additional water available or potable reuse projects are deemed to be infeasible, EVMWD could choose to implement an NPR system at the Regional WRF. This Regional system could be fed either with flows from Regional WRF, the Wildomar system, or another source of RW.

-This Page Intentionally Left Blank-

Chapter 9

CAPITAL IMPROVEMENT PLAN

9.1 Introduction

This chapter presents the recommended Capital Improvement Plan (CIP) projects, which are based on the analyses of the existing system and future system described in Chapter 7 and 8, respectively. The proposed projects aim to address existing system deficiencies, replace aging infrastructure, and provide the facilities necessary to meet future growth. The major project categories include pipeline projects, storage tank projects, pump addition/replacement projects and Indirect Potable Reuse (IPR) projects.

9.2 Phasing

The phasing of the improvements was based on the following considerations:

- Replacement of aging infrastructure.
- The need to address existing system deficiencies.
- The needs to meet the demands of anticipated future developments.

Projects required to meet the existing system deficiencies are given the highest priority and are recommended in the 2023 to 2025 planning period. Beyond 2025, the planning periods are categorized into five-year planning periods (grouped by fiscal year) as follows: 2025-2030, 2030-2035, 2035-2040, 2040-2045 and 2045-2050. The prioritization of the projects provides Elsinore Valley Municipal Water District (EVMWD) with a CIP that focuses on the most urgent projects first.

It is important to note that the phasing of existing system projects is presented as a planning guideline and is subject to the availability of funds and other system improvement needs and uncertainties. The phasing of infrastructure that addresses future growth through year 2050 is based on information provided by EVMWD for planned developments within the service area and expected dates of construction. The actual timing of future facilities will be dependent upon the actual rate of growth and the timing of new developments expected in the service area.

9.3 Cost Estimating Basis

The Opinion of Probable Construction Cost (OPCC) is developed based on the costs obtained from discussions with EVMWD. Some key cost assumptions made to develop project costs are as follows:

- All costs are in 2023 United States dollars and are consistent with the AACE International guidelines for developing planning-level estimates (Class 4). Cost escalation is not included in this CIP.
- Costs are adjusted to the *Engineering News-Record* (ENR) Greater Los Angeles Construction Cost Index used of 14,033 in February 2023.
- The cost estimates do not include costs for land acquisition, easements, permits, right-of-way acquisition, or escalation.
- 20 percent of construction costs are included in the cost estimate as a construction cost contingency.
- 40 percent of construction and contingency costs are included in the cost estimate for engineering, construction management, planning, administration, and environmental and legal services.

Table 9.1 to Table 9.4 show the unit construction cost for different types of assets that are included in the recycled water (RW) CIP projects.

Table 9.1 Pipeline Unit Costs

Diameter (Inches)	Construction Cost (\$/Linear Feet)
4	\$240
6	\$310
8	\$325
12	\$390
16	\$470
20	\$570
24	\$630
30	\$750
36	\$850
42	\$1,000
48	\$1,150

Table 9.2 Storage Tank Costs (2023 Dollars)

Volume (MG)	Construction Cost (\$/Gallon)
0.1	\$8.00
0.2	\$6.00
0.3	\$4.00
0.5	\$3.00
1	\$2.70
2	\$2.40
3	\$2.10
4	\$2.00
5 to 10	\$1.70

Notes:
Abbreviations: MG - million gallons.

Table 9.3 Booster Pump Replacement Costs (2023 Dollars)

Horsepower	Construction Cost (\$/Pump) ⁽¹⁾
0-50	\$40,000
50-100	\$60,000
100-200	\$80,000
200-500	\$100,000

Notes:
(1) The costs only include pump and motor costs.

Table 9.4 Booster Pump Station Costs (2023 Dollars)

New Booster Pump Station (gpm)	Construction Cost (\$/Pump Station) ⁽¹⁾
500 gpm or less	\$1,500,000
500 - 1,000	\$2,500,000
1,000 - 2,000	\$3,500,000
2,000 - 3,000	\$5,000,000
3,000 - 5,000	\$6,500,000
5,000 - 10,000	\$9,000,000

Notes:
Abbreviations: gpm - gallons per minute.
(1) Costs include the cost needed for the pump station structure.

9.4 Recommended Improvement Program

The unit construction costs listed in Table 9.1 through Table 9.4 are used to estimate construction costs for the recommended CIP projects. The projects are identified to replace aging infrastructure, address existing system deficiencies, and to provide adequate supply for planned future growth within the defined planning horizon through the year 2050. Assets required beyond 2050 are not included in this CIP. The CIP projects are categorized as projects related to aging infrastructure, existing system deficiencies and growth-related CIP.

9.4.1 Age Based Capital Improvement Projects

The useful life method is a technique that involves assigning a typical lifespan to an asset based on its type. When the asset has reached or is close to reaching the end of its useful life, it is included in the CIP for replacement. Table 9.5 provides estimates of the useful life for each project type. These estimates are intended to assist in budgeting rather than to identify specific projects, as specific needs should be identified through asset management practices.

Table 9.5 Typical Useful Life of Assets

Asset	Typical Useful Life (Years)
Pipelines	75
Storage Tanks/Reservoirs	75
Pump Station Building	75
Pumps, Electrical, and Instrumentation Equipment	20

9.4.2 Capacity Based Capital Improvement Projects

The capacity-based CIP prioritizes projects aimed at addressing any identified deficiencies in the four existing RW systems, as per the current demand conditions. Currently, due to the relative newness of the RW infrastructure, the only capacity deficiency exists in the Horsethief system. Therefore, it is recommended to install an additional pump at the Horsethief 1 Pump Station to mitigate this deficiency. As of now, no other existing system capacity-based CIP projects are identified in the RW system.

9.4.3 Potential Future Growth-Related Capital Improvement Projects

Projects in two of EVMWD's four RW systems have been recommended based on potential future growth, as outlined in Chapter 8 of this plan. These projects are summarized as follows:

- Wildomar System:** No future expansion is recommended due to insufficient water supplies once the Back Basin wetlands are connected to the system. The Back Basin wetlands are currently under design and are not considered a

CIP project. As a result, no growth-related CIP projects are needed for the Wildomar system.

- **Railroad Canyon System:** No growth-related projects were identified for the Railroad Canyon System due to insufficient RW supplies.
- **Horsethief System:** Growth-related CIP projects were identified for the Horsethief system which included pipeline projects for developments in the mid-term and the long term and the construction of a new 68,000-gallon capacity storage tank in the 1844 Zone.
- **Regional System:** The IPR project was identified as a future growth-related project.

The projects identified for each system along with their costs are presented in subsequent sections.

9.4.4 CIP Projects and Costs by System

The CIP projects and their associated costs are described for each of the four recycled systems: Wildomar, Railroad Canyon, Horsethief and Regional systems.

9.4.4.1 Wildomar System

The Wildomar system currently has no excess RW available, except during winter months. Consequently, expansion of the Wildomar system is not recommended, and no CIP projects are identified for future developments. However, if additional RW becomes available, EVMWD has evaluated Non-Potable Reuse (NPR) projects described in Chapter 8. Cost estimates for these projects are prepared in case future RW flows exceed projections in the Recycled Water System Master Plan (RWSMP) and EVMWD decides to implement the potential NPR system. The potential layout and cost estimates for the Wildomar NPR system are presented in Appendix E.

9.4.4.2 Railroad Canyon System

The Railroad Canyon Water Reclamation Facility (WRF) system does not have any plans for expansion, and there is no additional water available for new RW customers. While there is a possibility of a slight increase in future demands, the system has adequate capacity to accommodate it, and no capacity-based or growth-related CIP projects are recommended for this system. However, the pumps at the Canyon Lake Golf Course (CLGC) pump station and the Cottonwood Hills pump station have exceeded their useful life and require replacement. The five pumps will be replaced in the 2023-2025 cycle, and then again in the 2040-2045 cycle, as they reach the end of their useful life 20 years from installation. The cost of this pump replacement project due to aging infrastructure is \$880,000, as shown in Table 9.6, with a detailed breakdown presented in Appendix F. Figure 9.1 shows the proposed improvements.

Table 9.6 Railroad Canyon Pump Replacement Projects Cost

Project Location	Number of Pumps	Total Improvement Cost (\$)	Replacement Year
Cottonwood Hills Pump Station	3	\$300,000	2023-2025
CLGC Pump Station	2	\$140,000	2023-2025
Cottonwood Hills Pump Station	3	\$300,000	2040-2045
CLGC Pump Station	2	\$140,000	2040-2045
Total Cost		\$880,000	

9.4.4.3 Horsethief System

For the Horsethief system, the three pumps at the Horsethief Mid-Range Pump Station were installed in 1995 and the two pumps at the Horsethief WRF were installed in 2003. All these five pumps are currently past their useful life and are recommended for replacement in the 2023-2025 cycle. Once replaced, they would need to be replaced again in the 2045-2050 cycle as they would reach the end of their useful life in 20 years from installation. The new pump installed at the Horsethief 1 Pump Station will also need to be replaced as it reaches the end of its useful life in 2045-2050. The CIP project cost for these pump replacement projects due to ageing infrastructure is \$770,000 as shown in Table 9.7 and the detailed breakdown is presented in Appendix A.

Table 9.7 Horsethief Pump Station Age Replacement Cost

Project Location	Number of Pumps	Total Improvement Cost (\$)	Replacement Year
Horsethief 1 Pump 1 (at Horsethief Canyon WRF)	2	\$140,000	2025-2030
Horsethief 2 Pump 1 (Mid-Range)	3	\$210,000	2025-2030
Horsethief 1 Pump 1 (at Horsethief Canyon WRF)	2	\$140,000	2045-2050
Horsethief 2 Pump 1 (Mid-Range)	3	\$210,000	2045-2050
Replacement of New Pump at Horsethief 1 Pump Station (Horsethief Canyon WRF)	1	\$70,000	2045-2050
Total Cost		\$770,000	

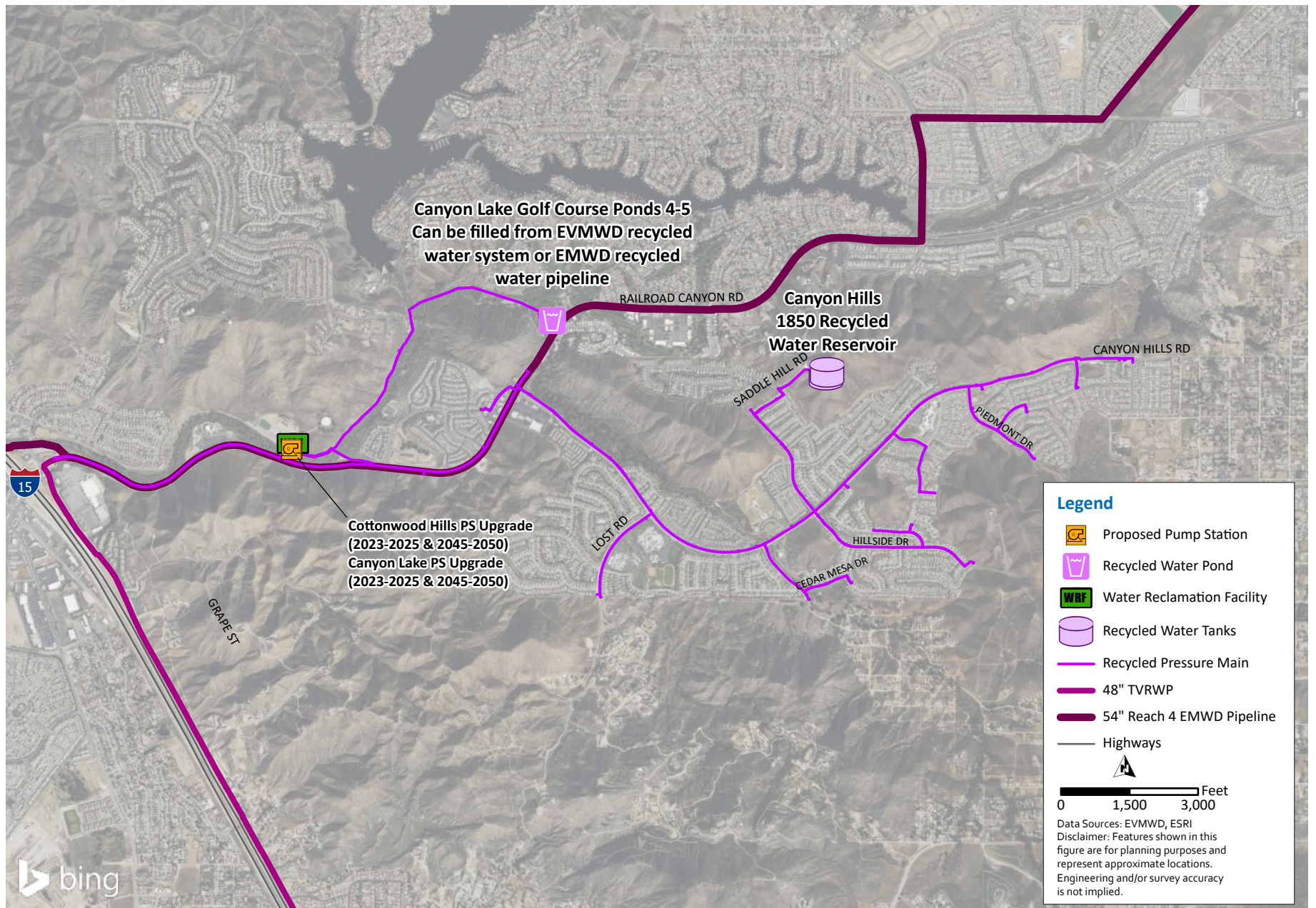

Figure 9.1 Railroad Canyon CIP Projects

-This Page Intentionally Left Blank-

To address the existing system deficiencies, an additional pump is needed at the Horsethief 1 Pump Station to the 1518 Zone. There is currently a storage deficiency in the system and building a new storage tank is recommended for the Horsethief system. Refer to Chapter 8 (Future System Analysis) for more details on these recommendations. The CIP cost to address these deficiencies is \$2.9 million as shown in Table 9.8 and the detailed breakdown is presented in Appendix A.

Table 9.8 Horsethief CIP Projects Cost for Capacity Based Improvements

Project	Total Improvement Cost (\$)
Horsethief 1 Pump Station (Additional Pump)	\$2,600,000
Horsethief 1844 Zone Storage Tank	\$300,000
Total Cost	\$2,900,000

The Horsethief system is expected to have potential developments in the mid-term and long-term. Pipeline projects are recommended to cater to these developments, with four projects identified for the mid-term (2025-2030) and two projects for the long-term (2040-2045). The cost of these growth-related projects is estimated at \$8 million, as shown in Table 9.9, with the detailed breakdown presented in Appendix F. The CIP improvements for the Horsethief system are shown on Figure 9.2.

Table 9.9 Horsethief CIP Projects Cost to Address Existing Deficiencies

Project	Total Improvement Cost (\$)
Pipeline Projects for Mid-Term Developments	\$5,800,000
Pipeline Projects for Long-Term Developments	\$2,200,000
Total Cost	\$8,000,000

9.4.4.4 Regional System

For the Regional System, groundwater augmentation using IPR is the recommended project although this may change as the economic and regulatory factors evolve. Based on the projected wastewater and thus RW flows, it is recommended that EVMWD will start construction of the advanced water purification facility (AWPF) in 2030. In addition to the AWPF, this IPR project includes construction of five new IPR injection wells. Three of the wells are assumed to begin construction approximately in 2030 with a volume of 3,375 acre-feet per year (AFY). The remaining two wells would begin construction approximately in 2036 with a volume of 6,750 AFY. The cost for this project is calculated by escalating the costs from the 2016 Indirect Potable Reuse Feasibility Study (KJ, 2017). The Greater Los Angeles Construction Cost Index was used to escalate the 2016 cost estimate to 2023 dollars. The total estimated capital cost for this project (for both phases) is \$164 million in 2023 dollars

as shown in Table 9.10, while the detailed breakdown is presented in Appendix F. The IPR project for Regional system is shown on Figure 9.3.

Table 9.10 Regional IPR Projects Cost

Project	2016 Capital Improvement Cost (\$) ⁽¹⁾	2023 Capital Improvement Cost (\$) ⁽²⁾
Regional IPR Project - Phase 1	\$45,700,000	\$105,000,000
Regional IPR Project - Phase 2	\$25,500,000	\$59,000,000
Total Cost	\$71,200,000	\$164,000,000

Notes:

(1) 2016 ENR index is 10,338.

(2) 2023 ENR index is 14,033.

9.4.5 CIP Projects by Phase

The CIP projects have been phased over a planning period of 25 years, from 2025 to 2050, with an additional planning period of 3 years (2023-2025).

The potential new developments in the Horsethief system will require the installation of new pipelines in the short-term (2025-2030) and long-term (2040-2045). The new pumps required for future growth in the Horsethief system are assumed to be in the same phase as the short-term developments (2025-2030).

A new storage tank will also be needed in the Horsethief system to account for future growth, which is phased in the short-term period (2025-2030), based on the anticipated timing of new development.

The IPR project, which involves the construction of five new injection wells and an AWPf, will be completed in two phases. The first phase will include the construction of three injection wells in 2030-2035, and the second phase will involve the construction of two more injection wells in 2036. The phasing of the project is based on the Indirect Portable Reuse Feasibility Study conducted by EVMWD in 2017.

The phasing of the new pump projects is determined based on the age of the pumps and the future growth needs. The pumps in the EVMWD system are beyond their useful life and are recommended for replacement in the 2023-2025 planning period.

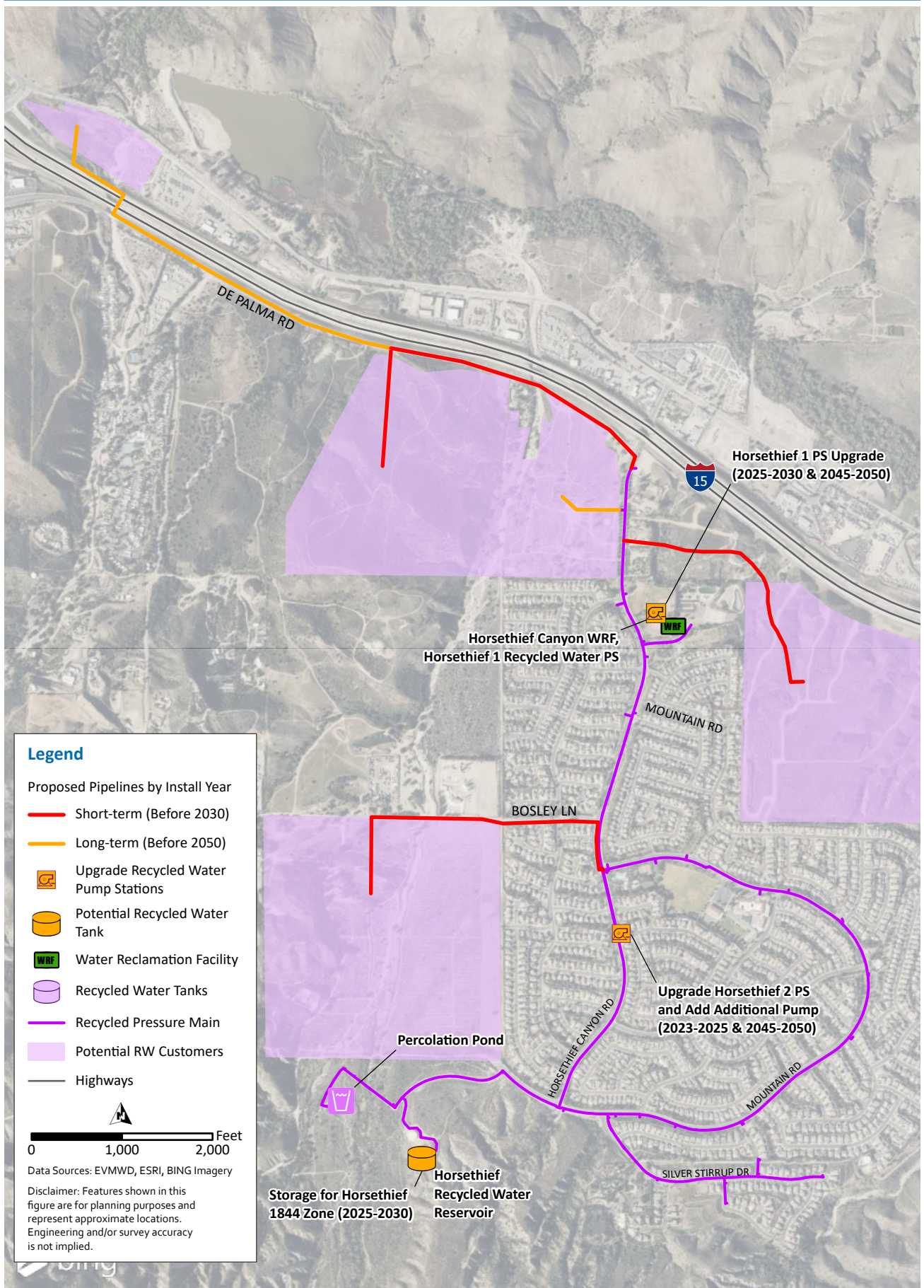

Legend

Proposed Pipelines by Install Year

- Short-term (Before 2030)
- Long-term (Before 2050)

- Upgrade Recycled Water Pump Stations
- Potential Recycled Water Tank
- Water Reclamation Facility
- Recycled Water Tanks
- Recycled Pressure Main
- Potential RW Customers
- Highways

0 1,000 2,000 Feet

Data Sources: EVMWD, ESRI, BING Imagery

Disclaimer: Features shown in this figure are for planning purposes and represent approximate locations. Engineering and/or survey accuracy is not implied.

Figure 9.2 Horsethief RW System CIP Projects

-This Page Intentionally Left Blank-



Figure 9.3 Proposed Back Basin IPR System

-This Page Intentionally Left Blank-

Table 9.11 summarizes the total RW system CIP improvements by phase and project type.

Table 9.11 RW System CIP Cost Summary by Phase and Project Type

RW Improvements	2023-2025	2025-2030	2030-2035	2035-2040	2040-2045	2045-2050
Pipelines	\$-	\$5.8 M	\$-	\$-	\$2.2 M	\$-
Potable Reuse	\$-	\$-	\$104.0 M	\$58.0 M	\$-	\$-
Pump Station Upgrade	\$-	\$2.6 M	\$-	\$-	\$-	\$-
Pump Replacement Program	\$0.4 M	\$0.3 M	\$-	\$-	\$0.4 M	\$0.4 M
Storage Tank	\$-	\$0.3 M	\$-	\$-	\$-	\$-
Total	\$0.4 M	\$9.0 M	\$-	\$58.0 M	\$2.6 M	\$0.4 M

Notes:
Abbreviations: M - million.

The total RW system CIP improvements are summarized in Table 9.12 by existing and future user cost. The costs associated with projects needed to address aging infrastructure issues and existing system deficiencies, such as the replacement of pumps and the construction of a new storage tank in the Horsethief system, are identified as existing user costs. These costs are assumed to be covered by existing users of the RW system. On the other hand, growth-related projects, such as the construction of new pipelines and the IPR project in the Regional system, are assumed to be funded by connection fees and future users. The allocation of costs between existing and future users is an important consideration for EVMWD in planning and implementing its CIP projects.

Table 9.12 RW System CIP Cost Summary by Existing and Future Users

Improvement Type	Existing User Cost (\$)	Future User Cost (\$)	Total Cost	Percentage
Pipelines	\$-	\$8.0 M	\$8.0 M	4.6%
Potable Reuse	\$-	\$162.0 M	\$162.0 M	92.9%
Pump Station Upgrade	\$2.5 M	\$-	\$2.5 M	1.4%
Pump Replacement Program	\$0.8 M	\$0.8 M	\$1.6 M	0.9%
Storage Reservoir	\$-	\$0.3 M	\$0.3 M	0.2%
RW Improvements Subtotal	\$3.3 M	\$171.1 M	\$174.4 M	100%

Figure 9.4 presents the distribution of all the CIP projects categorized by project type. The total estimated cost of RW CIP is approximately \$175 million, with the IPR project accounting for almost 93 percent of the total cost. Pipeline projects account for approximately 5 percent of the total CIP cost, while the remaining projects make up 2 percent of the total cost.

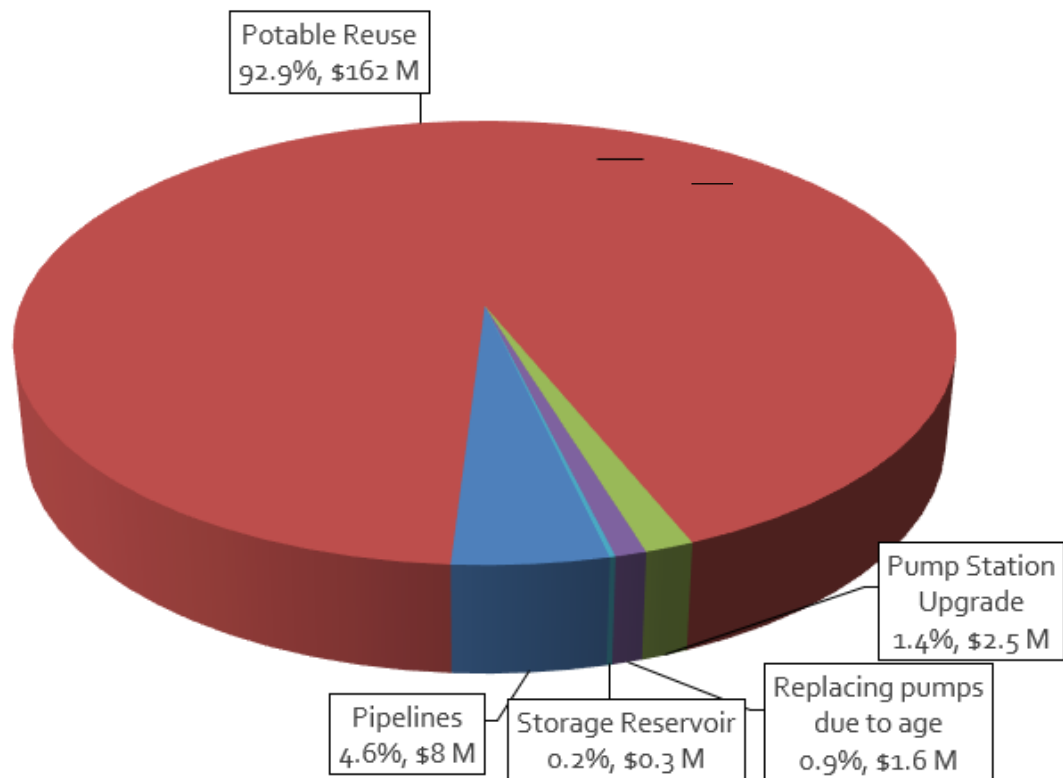

Figure 9.4 CIP Projects Based on Project Type

Figure 9.5 shows the distribution of the CIP projects based on the percentage of costs paid by existing and future users. The costs associated with addressing aging infrastructure issues and existing system deficiencies are classified as existing user costs, which account for only 2 percent of the total CIP costs. In contrast, growth-related projects are assumed to be funded by connection fees and future users, which account for 98 percent of the total CIP costs.

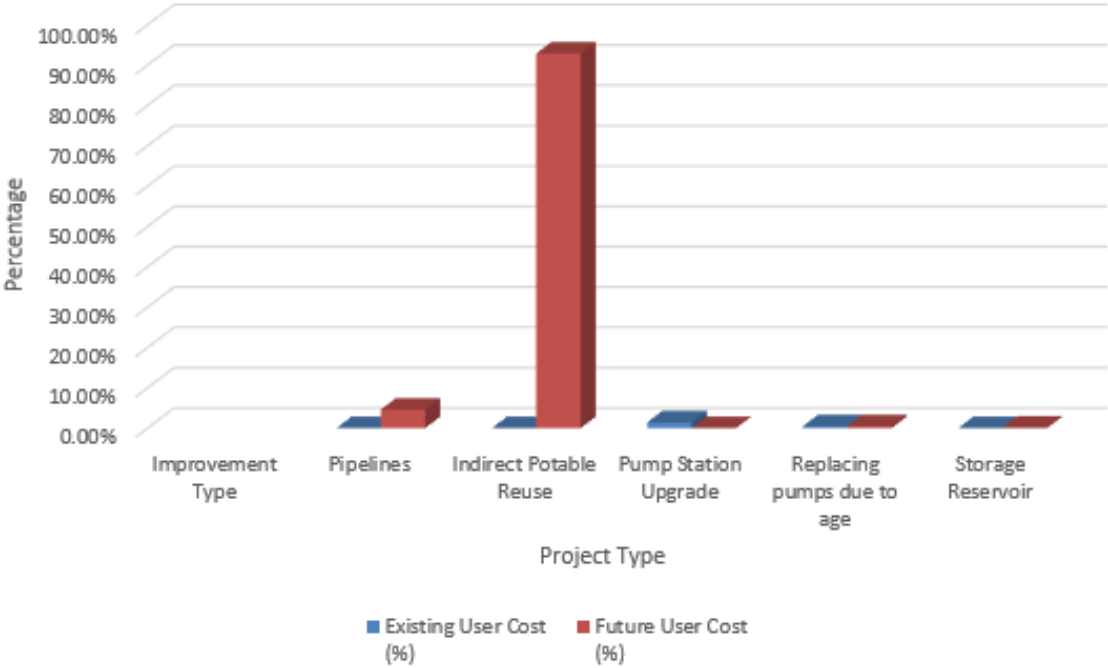

Figure 9.5 CIP Projects Based on User Cost

Figure 9.6 displays the distribution of all CIP projects over time. The majority of the costs associated with the first phase of the IPR project will be incurred during the 2030-2035 time period, amounting to \$113 million, which accounts for 65 percent of the total CIP costs. The next biggest cost, \$58 million, is projected to occur in the 2035-2040 time period and accounts for 33 percent of the total CIP cost, due to the second phase of the IPR project. The remaining 2 percent of the costs are spread across the 2023-2025, 2040-2045, and 2045-2050 time periods.

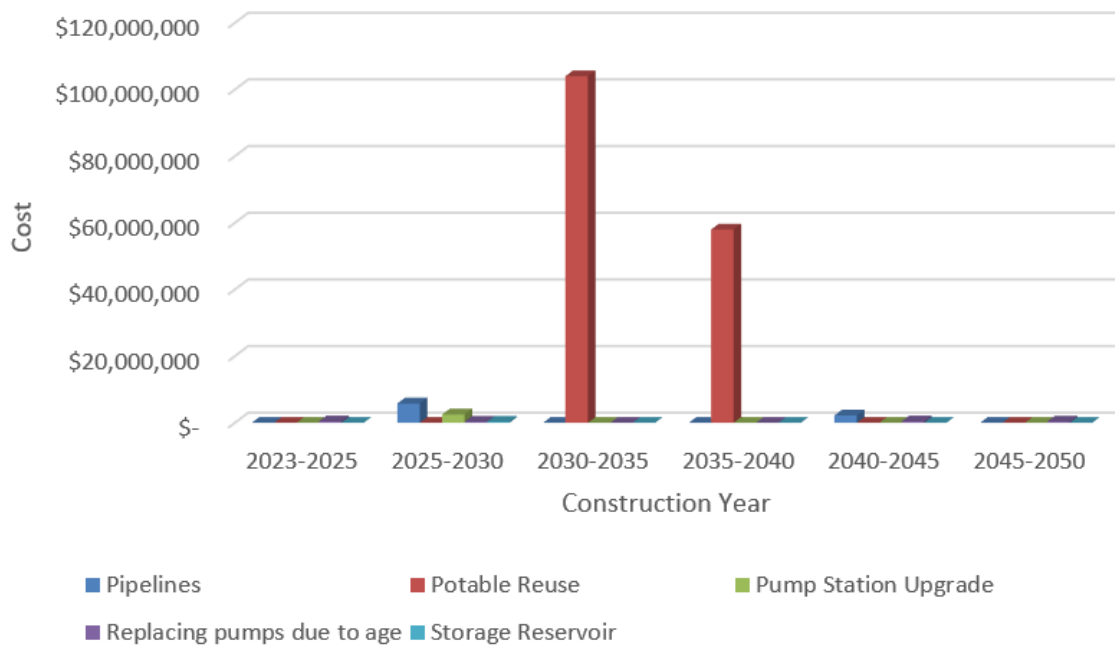

Figure 9.6 CIP Projects Based on Construction Time Period

Table 9.13 and Figure 9.7 show the distribution of the CIP projects by each of the RW system by phase. All the different types of projects in Horsethief Canyon system account for \$11.5 million which represents 6.6 percent of the total CIP costs. The costs for these projects are incurred in the 2025-2035, 2040-2045 and 2045-2050 time periods. The CIP projects in the Railroad Canyon system account for \$0.9 million representing 0.5 percent of the total CIP costs. These costs occur in the 2023-2025 and 2040-2045 time periods. The majority of the CIP costs are for the IPR project in the Regional system. The \$162 million IPR project account for approximately 93 percent of the CIP costs which occur in the 2030-2035 and 2035-2040 time periods.

Table 9.13 RW System CIP Cost Summary by System by Phase

System	2023-2025	2025-2030	2030-2035	2035-2040	2040-2045	2045-2050	Total
Wildomar	\$-	\$0	\$-	\$-	\$-	\$-	\$-
Horsethief Canyon	\$-	\$8.9 M	\$-	\$-	\$2.2 M	\$0.4 M	\$11.5 M
Railroad Canyon	\$0.4 M	\$-	\$-	\$-	\$0.4 M	\$-	\$0.9 M
Regional	\$-	\$-	\$104.0 M	\$58.0 M	\$-	\$-	\$162.0 M
CIP Total	\$0.4 M	\$8.9 M	\$104.0 M	\$58.0 M	\$2.6 M	\$0.4 M	\$174.4 M

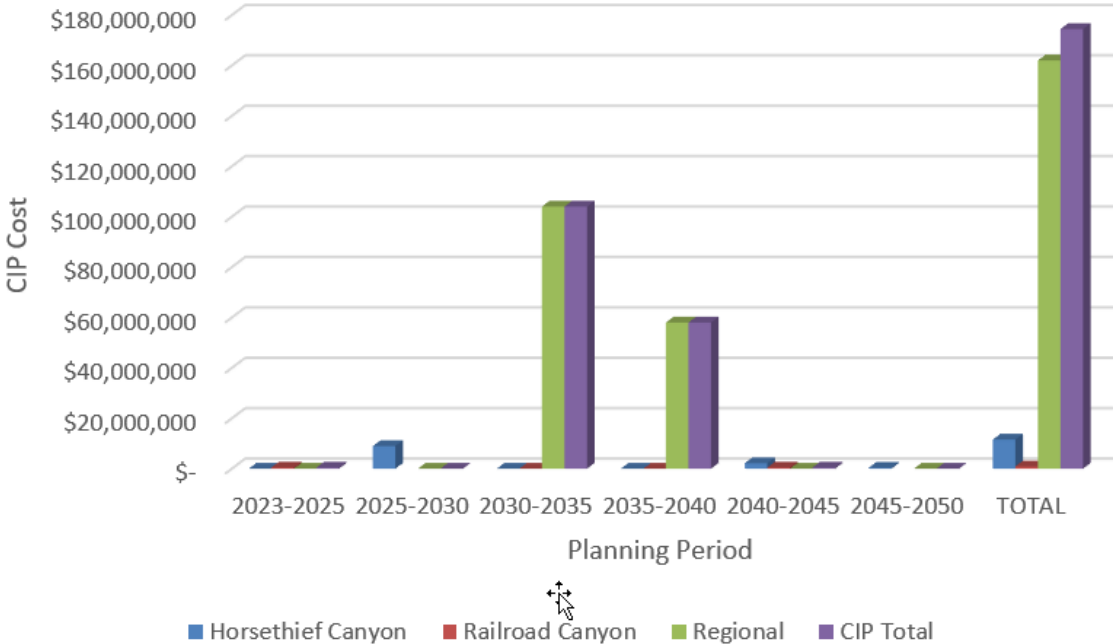

Figure 9.7 CIP Expenditure by System by Phase

9.5 Summary

The recommendations for the RW system are summarized in this CIP by project type, phase, and distribution of costs between existing and future users. The plan includes six projects to be completed by 2050 with a total cost of approximately \$175 million. The IPR project accounts for 93 percent of the total CIP cost, while pipeline projects account for 5 percent and pump station upgrades, pump replacement, and storage tank projects account for the remaining 2 percent. Future users will cover 98 percent of the total CIP cost, with existing users covering 2 percent. The costs are also distributed by phase, with approximately 65 percent of the total CIP cost being incurred in the 2025-2030 period, with the next major costs of 33 percent in the 2035-2040 period, primarily due to the IPR project.

-This Page Intentionally Left Blank-

Appendix A
REFERENCES

Appendix A

REFERENCES

- Dexter Wilson Engineering, Inc., 2022, Water System Analysis for Saddleback, March.
- Dudek, 2018, Plans for Regional Agricultural Pipeline Conversion, prepared for Elsinore Valley Municipal Water District, September.
- Eastern Municipal Water District and Elsinore Valley Municipal Water District, 2016, Interagency Agreement for the Purchase of Additional Capacity in Eastern Municipal Water District's Temecula Valley Recycled Water Transmission System, October 13.
- Eastern Municipal Water District and Elsinore Valley Municipal Water District, 2020, Amended and Restated Interagency Wholesale Recycled Water Agreement, June 25.
- Eastern Municipal Water District, Rancho California Water District, and Elsinore Valley Municipal Water District, 2004, Joint Participation in the Cost of Recycled Water Facilities, July 14.
- Eastern Municipal Water District, Rancho California Water District, and Elsinore Valley Municipal Water District, 2009, Agreement on Recycled Water Sales and Operating Costs, March 26.
- Engineering Science, 1983, Plans for the Construction of the Horsethief Canyon Wastewater Reclamation Facility, prepared for Elsinore Valley Municipal Water District.
- Elsinore Valley Municipal Water District, 2022, Geographic Information System (GIS). Received in June.
- G.V.W. Engineering, Inc., 1990, Horsethief Canyon Ranch Reclaimed Water Extension to Percolation Ponds, prepared for Elsinore Valley Municipal Water District.
- HDR, 2009, Phase 1 Recycled Water Project Engineering Report, prepared for Elsinore Valley Municipal Water District, July.
- Helix Environmental Planning, 2018, Regional Agricultural Pipeline Conversion Project, prepared for Elsinore Valley Municipal Water District.

Kennedy/Jenks Consultants, 2017, Indirect Potable Reuse Feasibility Study, prepared for Elsinore Valley Municipal Water District, March 24.

KWC Engineers, 2022, JBJ Ranch Recycled Water Study, May 31.

Mayers & Associates Civil Engineering, Tentative Tract Map No. 37002 for SAM.

MetroPointe Engineers, 2003, Canyon Lake Perc Pond Lining Project, prepared for Elsinore Valley Municipal Water District.

MWH, 2016, Recycled Water System Master Plan, prepared for Elsinore Valley Municipal Water District, August.

Sidawi & Associates, 1989, Horsethief Canyon Ranch Zone 2 Reclaimed Water Pumping Station, prepared for the Elsinore Valley Municipal Water District.

Waterworks Engineers, 2018, Contract Drawings for Railroad Canyon Water Reclamation Facility Yard Piping Modifications Project, prepared for Elsinore Valley Municipal Water District, June.

WSC, 2021, 2020 Urban Water Management Plan, prepared for Elsinore Valley Municipal Water District, June.

Appendix B

RECYCLED WATER AGREEMENTS

Following agreements are included in this Appendix:

Amended and Restated Interagency Wholesale Recycled Water Agreement between Eastern Municipal Water District (Eastern) and Elsinore Valley Municipal Water District (Elsinore)- June 2020.

Interagency Agreement for the Purchase of Additional Capacity in EMWD's Temecula Valley Recycled Water Transmission System between: Eastern Municipal Water District (Eastern) and Elsinore Valley Municipal Water District (Elsinore)- October 2016. Recycled Water Sales and Operation Costs between Eastern Municipal Water District (EMWD), Rancho California Water District (RCWD) and Elsinore Valley Municipal Water District (EVMWD)- March 2009.

Memorandum of Understanding (MOU) between Eastern Municipal Water District (EMWD), Rancho California Water District (RCWD) and Elsinore Valley Municipal Water District (EVMWD)- July 2004.

Agreement for Standby Recycled Water Connection between Eastern Municipal Water District (Eastern) and Elsinore Valley Municipal Water District (Elsinore)- May 2002.

**AMENDED AND RESTATED INTERAGENCY
WHOLESALE RECYCLED WATER AGREEMENT**

This Recycled Water Agreement ("Agreement") is made and entered into this 25 day of June, 2020, by and between **EASTERN MUNICIPAL WATER DISTRICT** ("Eastern") and **ELSINORE VALLEY MUNICIPAL WATER DISTRICT** ("Elsinore") both public agencies created pursuant to Division 20 of the California Water Code. Eastern and Elsinore may sometimes be collectively referred to herein as the "Parties."

RECITALS

WHEREAS, Eastern owns and operates four regional water reclamation facilities (hereinafter, "Eastern Facilities") which generate recycled water; and

WHEREAS, Elsinore desires to accept wholesale deliveries of recycled water from Eastern at Eastern's Railroad Canyon Road Reclaimed Water Turnout as was constructed pursuant to an Agreement for Standby Recycled Water Connection between Eastern and Elsinore, dated, May 15, 2002; and as generally shown and depicted on Exhibit A, which is attached hereto, and incorporated herein; and

WHEREAS, the above referenced Agreement has since expired, and Elsinore desires to continue the purchase of recycled water from Eastern for resale to Elsinore's retail recycled water customers for approved irrigation purposes, in accordance with applicable rules, regulations, policies and procedures; and

WHEREAS, on July 23, 2015 the Parties entered into the Subject Interagency Agreement for purposes of setting forth financial and other arrangements for the provision of wholesale recycled water service by Eastern to Elsinore at the Railroad Canyon Road Reclaimed Water Turnout located at 32145 Railroad Canyon Road in the City of Canyon Lake, California; and

WHEREAS, the Parties desire to extend the term of the Subject Interagency Agreement from its current expiration date of March 31, 2020 to March 31, 2030; and

WHEREAS, the Santa Ana Regional Water Quality Control Board has authorized Elsinore to continue the use of recycled water from Eastern; and

WHEREAS, the purpose of this Interagency Agreement is to set forth financial and other arrangements between Eastern and Elsinore for the provision of wholesale recycled water service by Eastern, under Eastern's Rate Code R4RC as may be periodically replaced or amended.

NOW, THEREFORE, in consideration of the above recited premises, together with the mutual covenants herein contained, the Parties agree as follows:

AGREEMENT

1. Incorporation of Recitals. The Recitals set forth above are incorporated into and are a part of this Interagency Agreement.
2. Wholesale Recycled Water Service. Eastern, hereby, agrees to provide wholesale recycled water service to Elsinore in the maximum amounts and flow rates prescribed herein. Such service shall be provided by Eastern to the Railroad Canyon Road Reclaimed Water Turnout located at 32145 Railroad Canyon Road in the City of Canyon Lake, California and identified on **Exhibit A**, hereto. Such, wholesale recycled water service shall be limited to three-hundred and twenty nine (329) acre-feet per calendar year ("annual allocation") and delivered at a maximum flow rate of 200 gallons-per-minute (gpm), unless additional volume and or flow rate is authorized by Eastern.

In the event that additional volume and or flow is authorized by Eastern; Eastern hereby agrees to adjust Elsinore's annual allocation by such authorized amount for the year in which the additional flow was approved. However, additional volume and or flow authorized by Eastern that is provided to Elsinore between the period of June 1st and October 31st of any year will be billed to Elsinore at Eastern's, then current, raw water rate (Rate Code RAUG), as described in Section 10, Purchase Price, herein, below.

3. Agreement Term.

This Agreement shall be effective beginning April 1, 2015 and shall remain in effect through March 31, 2030 unless sooner terminated by either party in accordance with Section 12, below. However, Elsinore acknowledges and agrees that throughout the term of this Agreement Eastern may once per year, effective on April 1st of each year, adjust the annual allocation (volume and or flow-rate) specified in Section 2, above, by written Amendment to this Agreement.

4. Rules and Regulations.

Elsinore shall, at all times, comply with all current Eastern, Federal, State, and local regulatory agency rules and regulations pertaining to the use and delivery of recycled water.

5. Eastern's Obligations and Responsibilities.

- A. Eastern shall supply recycled water meeting all applicable Federal, State, and Local regulatory agency standards for treated recycled water. Elsinore, hereby, acknowledges and agrees that Eastern's recycled water systems and facilities are not equipped to detect, treat, or remove harmful chemical or toxic materials except as required to meet such Federal, State and Local regulatory agency standards.
- B. Eastern Water Quality Reports related to Eastern Facilities ("Reports") will be made available to Elsinore and to its customers. These Reports refer to water

quality produced at Eastern's four (4) Regional Water Reclamation Facilities (RWRFs).

6. Elsinore's Obligations and Responsibilities.

- A. Elsinore shall, itself, be responsible for owning, operating, maintaining and repairing Elsinore's pipelines, pumps and appurtenant facilities, as are necessary to accept, convey, control, and use recycled water delivered by Eastern.
- B. Elsinore shall accept and use the recycled water in compliance with Eastern, Federal, State, and local regulatory agency requirements. Elsinore, hereby, agrees and shall be responsible to ensure that wholesale recycled water delivered to Elsinore by Eastern, pursuant to this Agreement, shall only be served to Elsinore customers located within the geographic boundaries depicted on **Exhibit B**, which is attached hereto, and incorporated, herein.
- C. Elsinore shall be, solely, responsible for any offset mitigation requirements for total dissolved solids and total inorganic nitrogen that is required for compliance with the water quality objectives for the groundwater management zones and surface waters specified in the Regional Water Quality Control Board's Water Quality Control Plan for the Santa Ana Basin (Basin Plan).
- D. Elsinore shall be responsible for ensuring backflow prevention at the point of connection with Eastern. No cost or expense, of any kind, relating to the installation, inspection, testing, and/or repair or replacement of a backflow prevention device shall be paid by or the responsibility of Eastern.
- E. Beyond (downstream from) the point-of-connection, full responsibility, liability, and accountability for the delivered water shall be that of Elsinore. Elsinore shall be fully responsible for any fines, penalties and/or legal costs as a result of Elsinore's failure to comply with any condition, term or standard required by any regulatory agency for recycled water downstream of the point-of-connection, and shall defend and hold Eastern harmless from any liability in connection, therewith. Elsinore will be responsible for all required sampling, monitoring, testing, and studies/reports required by the Santa Ana Regional Water Quality Control Board.

7. Acknowledgments by Elsinore.

- A. Eastern does not guarantee the availability of recycled water or pressure throughout the term of this Agreement. Elsinore is aware, and acknowledges, that delivery pressure varies throughout Eastern's recycled water distribution system. Elsinore shall, itself, be responsible for providing any and all pressure regulating or pumping facilities that may be necessary beyond the point of delivery. Changes in regulatory requirements and/or other conditions beyond Eastern's control may require operational changes which may also affect availability and pressure.
- B. Eastern's recycled water delivery systems are subject to both planned and unplanned shutdowns. When Eastern is aware of a planned shutdown, it will

attempt to notify Elsinore as soon as reasonably possible, but not less than forty-eight (48) hours in advance of such event. In the event of unplanned shutdowns, emergency outages due to pipeline breaks, leaks, or other similar occurrences, recycled water may not be available until repairs are complete.

8. Point of Connection.

Recycled water delivered pursuant to this Agreement shall be measured through metering facilities owned and operated by Eastern and located at Eastern's Railroad Canyon Road Reclaimed Water Turnout. Eastern shall calibrate the meter annually and shall make results available to Elsinore upon request.

9. Requests for Service to be Turned On/Off.

Elsinore shall provide Eastern a minimum of 24 hours advanced notice of any requests for service to be turned on or off; or requests for changes in flow. Elsinore shall contact Eastern's Integrated Operations Center ("I.O.C.") at (951) 928-3777, extension 6265, with the applicable account number when requesting such adjustments.

10. Purchase Price.

Elsinore shall pay Eastern billing charges in accordance with Resolution No. 3351.15, as amended, and Rate Code R4RC (currently \$327.92 per acre-foot); which charges are subject to periodic adjustment. However, additional volume and or flow requested by Elsinore and authorized by Eastern that is provided between the period of June 1st and October 31st of any year shall be billed to Elsinore at Eastern's then current raw water rate, Rate Code RAUG (currently \$755 per acre-foot), in accordance with Section 2, above.

Eastern will render a monthly invoice for recycled water deliveries made during the preceding month based on the meter reading made by Eastern at the Point of Delivery. Billings are due upon presentation of the statement and become delinquent if not paid within thirty (30) days from the date of such billing.

11. Hold Harmless.

Elsinore shall defend, indemnify, and hold Eastern, its officers, directors and Representatives ("Indemnitees"), harmless from and against any all claims, costs, liabilities, debts, demands, suits, actions, causes of action, proceedings, damages, judgments, liens, expenses or obligations including attorneys' fees and charges and the costs of all other professional and court or arbitration or other dispute resolution costs (collectively "Costs") which may be made arising out of or in connection with (a) this Agreement; (b) any breach by Elsinore of its obligations under this Agreement; (c) any enforcement by Eastern of any provision of this Agreement. The foregoing indemnity shall not apply to the extent any such Costs are ultimately established by a court of competent jurisdiction to have been caused by the sole negligence or willful misconduct of the Indemnitees or any of them. Eastern shall make all decisions with respect to its representation in any legal proceeding concerning this section. If Elsinore fails to do so,

Eastern shall have the right, but not the obligation, to defend the same and charge all of the direct or incidental Costs of such defense, including fees and costs, to Elsinore and to recover the same from Elsinore. The term "Representative" shall mean employees, representatives, agents, contractors, subcontractors or any other person directly or indirectly employed by one of the foregoing or reasonably under the control of any of the foregoing or for whose acts any of the foregoing may be liable.

12. Termination.

- A. For Convenience. Elsinore may terminate this Agreement at any time by giving Eastern thirty (30) days written notice.
- B. For Cause. In the event that Elsinore, without authorization, exceeds the annual allocation limits prescribed herein, Eastern, at its sole discretion, reserves the right to immediately terminate this Agreement. In addition, should Elsinore be in default as a result of failing to perform any of its obligations under this Agreement, and should Elsinore fail to cure such default within ten (10) days of written notice, Eastern may immediately terminate this Agreement.
- C. Without Cause. Eastern shall have the right to terminate this Agreement by giving Elsinore thirty (30) days written notice. In the event of any such termination, Eastern shall not be responsible for any direct, indirect, or consequential costs, damages, or liabilities associated with such termination.

In the event of termination, for any reason whatsoever; Elsinore shall be responsible for payment of recycled water deliveries made by Eastern up to the effective date of such termination.

13. Disputes.

In the event that any dispute between the Parties arises under this Interagency Agreement, the Parties shall first attempt to resolve such dispute at the management level. If the dispute is not resolved at this level within a mutually acceptable period of time (not to exceed 30 calendar days from the date written notice of such dispute is delivered by any Party), the Parties shall attempt to resolve the dispute at the senior management level. If this process and the involvement of senior management does not result in resolution of the dispute within 45 days from the date of referral to upper management, then the dispute shall be referred to and finally resolved through legal proceedings. The use of the foregoing procedure is a condition precedent to the commencement of any legal proceedings hereunder.

14. Amendments. It is understood that any alteration or variation of the terms of this Agreement will not be valid unless made in writing and signed by both parties, and that this Agreement supersedes and completely extinguishes all prior understandings or agreements between the Parties as to the subject matter hereof, and constitutes the entire agreement between both Parties.

15. Partial Invalidity. If any provision of this Agreement is held by a court of competent jurisdiction to be invalid, void or unenforceable, the remaining provisions will nevertheless continue in full force and effect without being impaired or invalidated.
16. Notices. Any notice required by this Agreement to be given or delivered to any Party shall be deemed to have been received when personally delivered or mailed in the United States mail addressed as follows:

Eastern Eastern Municipal Water District
Post Office Box 8300
Perris, Ca. 92572-8300
Attn: General Manager

Elsinore Elsinore Valley Municipal Water District
Post Office Box 3000
Lake Elsinore, Ca. 92531
Attn: General Manager

IN WITNESS WHEREOF, the parties have caused this Agreement to be executed as of the date first above written.

EASTERN MUNICIPAL WATER DISTRICT

ELSINORE VALLEY MUNICIPAL WATER DISTRICT

By: 
Paul D. Jones II, P.E., General Manager

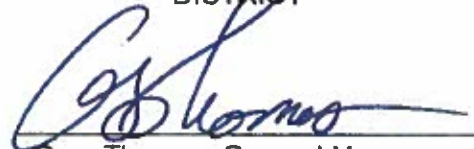
By: 
Greg Thomas, General Manager

Dated: 6/25/20

Dated: June 24, 2020

BID/AGREEMENT SUMMARY

Bid Summary

Project Name: Interagency Agreement for The Purchase of Additional Capacity in EMWD's Temecula Valley Recycled Water Transmission System CIP/Act No: n/a

Project Address: Temescal Valley RW

Brief Description: e of Additional Capacity in EMWD's Temecula Valley Recycled Water Transmission System

Type of Bid: RFP - PSA BB&K review due date: unkn Reviewed by: Margie

Type of Funding: District Funding Agency: N/A

Date BB&K returned: unkn Vendor Class: n/a Est. Total Proj Costs: n/a 1st Bid Adv Date: n/a

Agreement Summary

Agreement Party: Eastern Municipal Water District Agreement No.: n/a

Vendor Number: n/a CLSB Number: n/a DIR Registration Number: n/a

Contractor Classification Type: n/a

Type of Action: New Type of Contract: Cooperative

Agreement Start Date: 10/13/16 Agreement End Date: n/a Requisition Number: N/A

District Agreement Contact: Margie Armstrong Board Approval Date: 10/13/16

Additional Review Needed? by: n/a Requisition Amount: 785,215.00

Submission Date: 10/7/16 Sect. 700 Requirements: N/A If CO, Total Rev. Amount: N/A

Scope of Work/Deliverables/ Special Considerations/Notes:

Payment within 60 days

Contracted Party Contact/Notification Information: (Legal Notices)

Contract Rep Name: Current Position Holder Phone:

Title: General Manager Email:

Address: PO Box 8300

City: Perris State: CA Zip: 92572 Other contact no.:

Key Personnel:

Distribution Requests:

To send to Contracted Party: Agreement via Email interoffice to: Margie/Barbara

Enclosures: NTP PO Other # of Original Copies rec'd 2

In-house Distribution: Accounting Optional: Optional:

Special Instructions:

Send executed email copies to Margie, Barbara, & Art. EVMWD signs first. Barb to create check request.

INTERAGENCY AGREEMENT FOR THE PURCHASE
OF ADDITIONAL CAPACITY IN EASTERN MUNICIPAL WATER DISTRICT'S
TEMECULA VALLEY RECYCLED WATER TRANSMISSION SYSTEM

This Agreement is made and entered into this 13th day of October, 2016, by and between **EASTERN MUNICIPAL WATER DISTRICT** (hereinafter "Eastern") and **ELSINORE VALLEY MUNICIPAL WATER DISTRICT** (hereinafter "Elsinore"), both agencies organized and operating pursuant to Division 20 of the California Water Code.

RECITALS

WHEREAS, Eastern owns and operates the Temecula Valley Recycled Water Transmission System, hereinafter referred to as the "Subject Facilities", and generally depicted on the map attached hereto as **Exhibit A**; and

WHEREAS, on July 14, 2004, Eastern, Elsinore, and the Rancho California Water District, hereinafter "Rancho", entered into a Memorandum of Understanding (MOU) for Joint Participation in the Cost of Recycled Water Facilities, thereby formalizing an understanding between the Parties for the purchase of capacity in the Subject Facilities; and

WHEREAS, in accordance with the aforementioned MOU, Elsinore purchased 1.54 Million Gallons per Day (MGD) of capacity in the Subject Facilities; and

WHEREAS, on March 26, 2009, Eastern, Elsinore and Rancho entered into the Recycled Water Sales and Operating Costs Agreement, incorporated herein by reference, establishing the mutual understandings amongst the Parties related to wholesale recycled water sales and/or the discharge of recycled water through the Subject Facilities; and

WHEREAS, on July 2, 2014, Eastern and Elsinore entered into a Memorandum of Understanding (MOU) for Recycled Water Operational Requirements, incorporated herein by reference, for purposes of formalizing a mutual understanding regarding operation and maintenance responsibilities associated with deliveries of recycled water through the Subject Facilities; and

WHEREAS, at this time Elsinore desires to purchase an additional .46 MGD of capacity in the Subject Facilities from Eastern for a combined total capacity of 2.0 MGD (1.54 MGD + .46 MGD); and

WHEREAS, Eastern has agreed to sell the aforementioned .46 MGD of capacity to Elsinore for the total sum of \$785,215 under the terms and conditions described herein; and

WHEREAS, the purpose of this Interagency Agreement is to set forth the terms, conditions and mutual understandings whereby Eastern agrees to sell .46 MGD of capacity in the Subject Facilities to Elsinore.

NOW, THEREFORE, in consideration of the premises and covenants herein contained, the parties agree as follows:

AGREEMENT

1. Incorporation of Recitals. The Recitals set forth above are incorporated into and are a part of this Interagency Agreement.

2. Purchase of Capacity. Eastern hereby agrees to sell Elsinore .46 MGD of capacity in the Subject Facilities for the total sum of \$785,215. Such price is based on the cost of Elsinore's original purchase of 1.54 MGD of capacity pursuant to the aforementioned July 14, 2004 MOU, and has been adjusted to current in accordance with the Engineering News Record Construction Cost Index (ENR-CCI). Elsinore hereby certifies that it has reviewed and agrees with such determination of cost, and that the aforementioned price represents fair and reasonable consideration to Eastern. Elsinore further acknowledges and agrees that Elsinore's .46 MGD of purchased capacity shall be limited to a maximum flow rate of 322 gallons per minute (gpm), without prior authorization from Eastern.
3. Description and Location of the Subject Facilities. The Subject Facilities are generally depicted on **Exhibit A**, attached hereto, and consist of approximately 12 miles of 48-inch diameter recycled water pipeline and an in-line booster facility located at 21422 Palomar Road, Wildomar, California. The Subject Facilities additionally consist of approximately 2.4 miles of 54-inch diameter recycled water pipeline extending from Railroad Canyon Road to, and including, Eastern's discharge and Reach 4 Energy Dissipation Facility located at 636 West Minthorn Street in Elsinore, California.
4. Ownership of the Subject Facilities. It is hereby understood and agreed that Eastern shall retain sole ownership of the Subject Facilities. Elsinore's purchase under this agreement is limited solely to .46 MGD of capacity as defined in Section 2, above.
5. Payment. Elsinore shall remit payment in the amount of \$785,215 to Eastern within 60 calendar days following final execution of this Interagency Agreement for the purchase of capacity contemplated herein.
6. Recycled Water Sales and Operating Procedures and Costs. Eastern and Elsinore hereby agree that all terms and conditions of the March 26, 2009 Recycled Water Sales and Operating Cost Agreement, and MOU for Recycled Water Operational Requirements dated July 2, 2014, both incorporated herein by reference, shall also apply to Elsinore's purchase of .46 MGD pursuant to this Agreement.
7. Indemnification. Eastern and Elsinore each hereby agree to indemnify, defend, save and hold harmless the other party and their respective officers, agents and employees, of and from any liabilities, claims, demands, suits, action and cause of action arising out of or in any manner connected with this Interagency Agreement, or for any act or omission of such indemnifying Party, performed in connection with therewith.
8. Binding Provision. This Interagency Agreement is binding on the heirs, representatives, successors and assigns of the Parties hereto.
9. Notices. Any notice required by this Interagency Agreement to be given or delivered to any Party shall be deemed to have been received when personally delivered or mailed in the United States mail addressed as follows:

Eastern Eastern Municipal Water District
Post Office Box 8300
Perris, Ca. 92572-8300
Attn: General Manager

Elsinore

Elsinore Valley Municipal Water District
P.O. Box 3000
Lake Elsinore, Ca. 92530
Attn: General Manager

IN WITNESS WHEREOF, the Parties have executed this Agreement as of the day and year first above written.

ELSINORE VALLEY MUNICIPAL WATER DISTRICT

By:



John D. Vega, General Manager

Dated:

10/12/16

EASTERN MUNICIPAL WATER DISTRICT

By:



Paul D. Jones II, P.E., General Manager

Dated:

10.24.16

AGREEMENT
RECYCLED WATER SALES AND OPERATING COSTS

This Agreement is made and entered into this 26th day of March, 2009, by and among **EASTERN MUNICIPAL WATER DISTRICT** organized and operating pursuant to Division 20 of the California Water Code (hereinafter "EMWD"), **RANCHO CALIFORNIA WATER DISTRICT** organized and operating pursuant to Division 13 of the California Water Code (hereinafter "RCWD") and **ELSINORE VALLEY MUNICIPAL WATER DISTRICT** organized and operating pursuant to Division 20 of the California Water Code (hereinafter "EVMWD"). EMWD, RCWD and EVMWD are sometimes individually referred to herein as the "Party" and collectively as the "Parties."

RECITALS

- A. EMWD and RCWD previously entered into and executed a Wastewater Management Agreement dated June 23, 1989, to provide for coordinated operation of their respective wastewater service systems. The intent was to provide wastewater service in the most economical manner regardless of jurisdiction.
- B. As part of this coordinated effort, both EMWD and RCWD have expanded their recycled water distribution systems and have constructed intertie facilities connecting EMWD's Temecula Valley RWRf and RCWD's Santa Rosa WRF to maximize the beneficial sale and use of reclaimed water within and adjacent to their respective service areas.
- C. Temecula Valley RWRf and Santa Rosa WRF discharge excess recycled water into EMWD's Temecula Valley pipeline to a connection on the Reach 4 line upstream of the discharge facility at Temescal Creek as shown on the attached figure. In addition, raw sewage from EVMWD is transported to RCWD's Santa Rosa WRF, treated and used for local supply or placed into EMWD's Temecula Valley pipeline to serve beneficial use deliveries within EVMWD. Both RCWD and EVMWD purchased capacity (2.46 MGD and 1.54 MGD, respectively) in EMWD's Temecula Valley Pipeline and Reach 4 discharge pipelines.
- D. To date, several MOU's/Agreements and Addendums to the June 23rd Agreement have been executed by and between Parties with respect to the delivery of recycled

water, construction and maintenance of mutually beneficial facilities, and financial and other obligations. Due to plant and pipeline infrastructure improvements and other factors, many of these contracts contain provisions that are no longer practicable or viable.

- E. The purpose of this agreement is to confirm the contractual provisions contained in the prior agreements and to formalize the mutual understanding among the Parties related to wholesale recycled water sales and/or discharge of recycled water through the Temecula Valley pipeline.

NOW, THEREFORE, in consideration of the above-recited premises, together with the mutual covenants herein contained, EMWD, RCWD, and EVMWD agree as follows:

AGREEMENT

1. Recycled Water Sales to RCWD

- A. Confirmation of EMWD Recycled Water Supply to RCWD. RCWD is responsible for providing retail recycled water to its customers within its service area. The primary source of RCWD's recycled water supply is that which is generated from its Santa Rosa WRF. In addition, RCWD buys wholesale recycled water from EMWD as necessary to meet customer demands in excess of flows generated from Santa Rosa WRF. Under the Wastewater Management Agreement dated June 23, 1989, as amended by Addendum No. 1 dated October 8, 1993, EMWD agreed to sell a 'Minimum Basic Quantity' of 1.8 MGD to RCWD on a take or pay basis (Section XVII-A of Addendum 1) and to sell additional recycled water, up to 5 MGD, to RCWD on an 'As Available' basis (Section XVI-A of Addendum 1). Said recycled water supply agreement provisions are hereby confirmed and, notwithstanding the term of this Agreement, made perpetual.

- B. EMWD Billing for Recycled Water Supply to RCWD. EMWD will bill RCWD monthly for all recycled water deliveries to RCWD through metering devices at points of delivery. The metering devices shall meet EMWD's requirements and include necessary SCADA, telemetry capabilities, pressure and flow monitoring, valves, access, and security features designed and constructed by RCWD at RCWD's expense per EMWD's requirements. In the event that the total deliveries during a calendar month do not total 1.8 MGD (5.52 acre-feet) average, EMWD shall also invoice RCWD for the recycled water not accepted (i.e. 1.8 MGD or 5.52 acre-feet multiplied by the number of calendar days in the month less recycled water accepted, stated as MGD or AF). The total deliveries and EMWD's 'Minimum Basic Quantity' commitment to RCWD shall be calculated monthly based on the cumulative of metered flow to RCWD's and EVMWD's (see Paragraph 2) metered turnouts along the Temecula Valley Pipeline (TVP) located between the Palomar Booster Station and Dissipater Facility.

- C. Price of Recycled Water. The price per acre foot shall be EMWD's then-in-effect wholesale recycled water rate, current rate R4RC at \$180.50/AF, subject to periodic adjustment.

- D. Indemnification. RCWD will defend and indemnify EMWD from any claims or losses arising out of or in connection with the use of the recycled water delivered to RCWD by EMWD.

2. Recycled Water Sales to EVMWD.

- A. Delivery Point for Recycled Water from EMWD. Recycled water deliveries by EMWD to EVMWD from the Reach 4 Pipeline shall be at turnouts approved by EMWD; each delivery point shall be metered. The metering devices and turnouts shall include necessary SCADA, telemetry capabilities, pressure and flow monitoring, valves, access, and security features designed and constructed by EVMWD at EVMWD's expense per EMWD's requirements.

- B. Annual Reconciliation of Billing. At the beginning of each fiscal year, EVMWD's recycled water allocation shall be adjusted based on EVMWD's actual average daily flow contribution to the Santa Rosa WRF during the previous fiscal year. Based on this adjusted allocation, EVMWD and RCWD shall reconcile commodity charges associated with EVMWD's actual contribution to Santa Rosa WRF.

 - C. Billing for Recycled Water from EMWD. EMWD will bill EVMWD monthly for all recycled water deliveries to EVMWD through metering devices at points of delivery, except for 1.00 MGD (3.07 AF) average or then-in-effect EVMWD allocation (calculated on a monthly basis) taken at metering stations along the Temecula Valley Pipeline between the Palomar Booster Station and the Dissipater Facility. The credit of 1.00 MGD (3.07 AF) or then-in-effect EVMWD allocation does not apply to EVMWD recycled water purchases for Canyon Lake or any other turnouts located outside of the TVP reach described above.

 - D. Price of Recycled Water. The price per acre foot shall be EMWD's then-in-effect wholesale recycled water rate, current rate R4RC at \$180.50/AF, subject to periodic adjustment.

 - E. Surplus Recycled Water. EMWD agrees to sell surplus recycled water to EVMWD, on an as-available basis, with the understanding that current and future EMWD customers will have priority to recycled water supplies and there is no implied guarantee of availability of surplus recycled water to EVMWD.
3. EVMWD's Excess Recycled Water. RCWD has no obligation to take or to store recycled water that EVMWD cannot reuse and may refuse this recycled water at any time it does not have storage or reuse capacity.

4. Temecula Valley Pipeline/Palomar Booster Operational Costs. Each party shall be responsible to pay its proportionate share of the operational costs associated with the Temecula Valley Pipeline and Palomar Booster Station system. The cost will be calculated on a monthly basis by EMWD and invoiced to EVMWD and RCWD on an annual basis as follows:

Elsinore Valley Municipal Water District:

$$J \times E = D$$

J = Operational Rate per MG (Avg. annual operational costs for Palomar Booster divided by flows processed thru respective facility)

E = Total recycled water deliveries during month from EMWD provided to EVMWD at metered turnouts along the TVP located between the Palomar Booster and the Dissipater Facility. The value of "E" shall be a minimum of 1.00 MGD (or then-in-effect EVMWD allocation), regardless of the actual recorded value. The value of "E" is exclusive of recycled water deliveries to Canyon Lake.

D = EVMWD proportionate share of monthly Operational costs

An annual reconciliation of flows and operational costs shall be performed by EMWD as follows:

Designation	E	G	H	I	J	M
	EMWD RW Deliveries to EVMWD (TVP Only)	EMWD RW Deliveries to RCWD	SRWRF Discharge to TVP	EVMWD Flow to SRWRF	EMWD Palomar BS Operational Rate	EMWD Dissipater Operational Rate
January						
↓						
December						
Totals						

If "H" is greater than 1.00 MGD average or then-in-effect EVMWD allocation (calculated monthly), then EMWD shall invoice RCWD for additional Operational costs associated with the Palomar BS and Dissipater Facility. The Operational cost shall be calculated as follows:

$$(H - (1.00 \text{ (or as appropriate) } \times \text{ calendar days per month})) \times (J + M) = K$$

H = Santa Rosa WRF Discharge to Temecula Valley Pipeline during calendar month (MG)

J = Operational Rate per MG (Average annual operational costs for Palomar Booster divided by flows processed thru respective facility)

M = Operational Rate per MG (Average annual operational costs for Dissipater Facility divided by flows processed thru respective facility)

K = RCWD monthly proportionate share of Operational costs

5. Temecula Valley Pipeline/Palomar Booster Maintenance Costs. As needed, it may be necessary to do preventative maintenance and/or repair on the Temecula Valley Pipeline and Palomar Booster Station system. These cost estimates shall be identified and shared proportionately by all parties based on the purchased capacity. Such costs shall be separated from the normal operating costs and a full detail of the final costs be included in the billing. Such work shall have been preapproved by the parties prior to beginning work unless the work being done is considered to be an emergency. In this case, each party will be notified within 48 hours of the nature of the emergency and potential costs.

6. Reporting Requirements. In order to calculate the amounts due for commodity charges and O&M costs, each party shall be responsible for providing the following information on a monthly basis to the other Parties of this Agreement to be used in the annual calculation:
 - a. RCWD shall report recycled water flows from the Santa Rosa WRF into the Temecula Valley Pipeline. RCWD shall also report all recycled water deliveries received from EMWD.

- b. EMWD shall report the total flow reads at the Palomar Booster and all operating and maintenance costs of the Temecula Valley Pipeline and Palomar Booster system.
 - c. RCWD shall report EVMWD's raw sewage influent flow contribution to the Santa Rosa WRF.
 - d. EVMWD shall report recycled water deliveries received from EMWD at metered turnouts located along the TVP between the Palomar Booster and Dissipater Facility.
7. System Shutdowns. The Temecula Valley Pipeline System and Palomar Booster Station are subject to planned and unplanned shutdowns. During such events, EMWD is not obligated to convey RCWD and EVMWD's flows from the Santa Rosa WRF. Shutdown notifications and protocol will be made and conducted in accord with the Operational Protocol prepared pursuant to paragraph 12.D, below.
8. EMWD Not Liable for Minimum Hydraulic Grade Line (HGL). Given that the mode of operation at the Palomar Booster Station will vary, EMWD does not guarantee the availability of a minimum HGL along the Temecula Valley Pipeline, other than the minimum HGL needed to convey flows to the Reach 4 discharge location at Temescal Creek.
9. Regulatory Requirements. Discharge of recycled water to Temescal Creek is performed by EMWD per NPDES permit requirements. Any violation of permit requirements due to Santa Rosa WRF effluent discharges to the Temecula Valley Pipeline shall be the responsibility of RCWD per Addendum No.1 to the Memorandum of Understanding (May 2006) for the Joint Participation In The Cost of Recycled Water Facilities agreement, Paragraph C, Liabilities and Compliance. RCWD shall defend and indemnify EMWD for any claims or losses arising out of or in connection with effluent discharges from the Santa Rosa WRF to the TVP.
10. Changes Affecting Prior Agreements. To the extent the terms and conditions contained herein are inconsistent with the terms and conditions contained in prior agreements, the terms and conditions in this Agreement shall govern.

11. Term. The term of this agreement shall be five (5) years from date of execution and will be automatically extended for additional five-year extensions unless all parties agree to amend.
12. Miscellaneous Provisions.
- A. In the event of circumstances that limit EMWD's ability to meet its recycled water delivery commitments, the parties to this Agreement shall confer and re-negotiate the terms and conditions of the Agreement.
 - B. Invoices submitted by EMWD to RCWD and EVMWD shall be paid in full within 90 calendar days. Failure of payment by either agency to EMWD within the prescribed period shall render this agreement null and void. EMWD shall notify both agencies 30 days prior to termination of this Agreement.
 - C. Recycled water deliveries maximum flow rates from EMWD to EVMWD shall not exceed 1,073 gpm (1.54 MGD) without prior authorization from EMWD.
 - D. Parties to this agreement shall develop a coordinated Recycled Water Operational Protocol that specifies the activities, communication, and operational limitations associated with delivery of recycled water from EMWD.

IN WITNESS WHEREOF, the Parties have caused this Agreement to be executed by its respective duly authorized officers.

EASTERN MUNICIPAL WATER DISTRICT

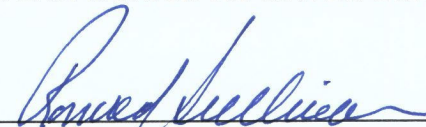
By: 
Ronald Sullivan, Board President

Attest:

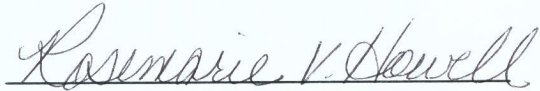

District Secretary

Dated: MARCH 26, 2009

Approved as to Form:

Redwine & Sherrill
District Counsel

ELSINORE VALLEY MUNICIPAL WATER DISTRICT

By: 
Phil Williams, Board President

Attest:

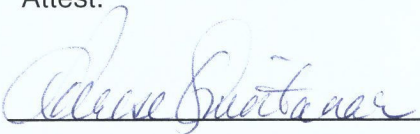
District Secretary

RANCHO CALIFORNIA WATER DISTRICT

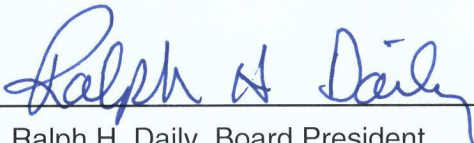
By: 
Ralph H. Daily, Board President

Attest:

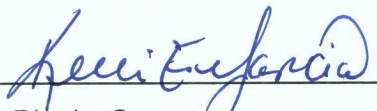
District Secretary

Approved as to Form:

Best Best & Krieger
District Counsel

MEMORANDUM OF UNDERSTANDING

JOINT PARTICIPATION IN THE COST OF RECYCLED WATER FACILITIES

This Memorandum of Understanding (MOU) is made and entered into this 14th day of July, 2004, by and among **EASTERN MUNICIPAL WATER DISTRICT** organized and operating pursuant to Division 20 of the California Water Code (hereinafter "EMWD"), **RANCHO CALIFORNIA WATER DISTRICT** organized and operating pursuant to Division 13 of the California Water Code (hereinafter "RCWD") and **ELSINORE VALLEY MUNICIPAL WATER DISTRICT** organized and operating pursuant to Division 20 of the California Water Code (hereinafter "EVMWD"). EMWD, RCWD and EVMWD are sometimes individually referred to herein as the "Party" and collectively as the "Parties."

WHEREAS, EMWD and RCWD own and operate treatment plant facilities in Temecula that produce recycled water as a by-product.

WHEREAS, EMWD and RCWD do not have sufficient facilities to transport excess recycled water generated from the plants to the Temescal Wash.

WHEREAS, EMWD is proposing a construction project referred to as the Temecula Valley Recycled Water Transmission System (hereinafter "Project") to transport the recycled water to an existing 54-inch recycled water pipeline at Railroad Canyon Road which connects to the Temescal Wash discharge point.

WHEREAS, on November 20, 2003 RCWD entered into an MOU with EMWD for the purchase of 4.0 MGD of capacity in the proposed facilities as well as capacity in EMWD's existing 54-inch pipeline and energy dissipation structure at the discharge point. EVMWD was not a party to that MOU.

WHEREAS, EVMWD has contracted with RCWD to treat up to 1.54 MGD of its raw sewage flows at RCWD's treatment facilities and would like to purchase capacity in the facilities and project described herein.

WHEREAS, RCWD's purchase under the prior MOU contained capacity that is duplicative of the EVMWD capacity, which is to be refunded to RCWD by EVMWD.

WHEREAS, the purpose of this MOU is to formalize the mutual conceptual understanding between the Parties relative to each Party's allocated share in the capital costs of the proposed and existing facilities and operational and maintenance costs.

NOW, THEREFORE, in consideration and furtherance of the above-recited premises, together with the mutual covenants herein contained, EMWD, RCWD and EVMWD agree as follows:

1. Description of the Construction Project. The Project, to be constructed by EMWD, consists of the approximately 12 miles of 48-inch diameter recycled water pipeline and an in-line booster pump station located at the intersection of Palomar Street and Gruwell Street. The preliminary capital cost estimate for the Project is \$39,000,000. The proposed pipeline will be sized to provide 32 MGD of capacity for EMWD, 2.46 MGD of capacity for RCWD, and 1.54 MGD of capacity for EVMWD and the booster pump station will be sized to provide 22 MGD for EMWD, 2.46 MGD for RCWD, and 1.54 MGD for EVMWD. The estimated completion date is the end of November 2004 for the pipeline installation and early spring 2005 for the in-line booster pump station.

2. Description of Existing Facilities. EMWD's existing recycled water facilities consist of approximately 2.4 miles of 54" diameter pipeline extending from Railroad Canyon Road to the discharge point, and EMWD's energy dissipation structure at the discharge point. These existing facilities have a capacity of 72 MGD.

3. Participant's Estimated Financial Participation. Based on reserved capacities noted, each Party's estimated share of the \$43,910,745 estimated capital cost is calculated as follows:

Facility	Est. Cost (\$)	Firm Capacity	RCWD ⁽¹⁾ Cost (\$)	EVMWD ⁽²⁾ Cost (\$)	EMWD Cost (\$)
Proposed 48" Pipeline	31,160,000	36	2,129,270	1,332,960	27,697,770
Proposed Pump Station	7,900,000	26	747,460	467,920	6,684,620
Existing 54" Pipeline	3,536,630	72	120,830	75,640	3,340,160
Existing Energy Dissipator	1,314,115	72	44,900	28,110	1,241,105
Credit for RCWD ⁽³⁾			(689,270)		
Total	43,910,745		2,353,190	1,904,630	38,963,655

Notes:

(1) RCWD cost based on needing 2.46 MGD of facility capacity.

(2) EVMWD cost based on needing 1.54 MGD of facility capacity.

(3) RCWD credit represents previous one-third capital cost participation for the existing 36-inch diameter recycled water transmission main.

Payment of EVMWD's \$1,904,630 estimated financial participation will be paid directly to RCWD as reimbursement for capacity purchased under the prior MOU to convey EVMWD generated flow. Payment is due and payable within 60 days from execution of this MOU. After completion of all work and determination of final costs, EMWD will notify the Parties of any additional payment owing or refund due. Additional payments or refunds are due within 30 days following EMWD's notification.

4. Maintenance and Operational Expenses. RCWD and EVMWD agree to pay their proportionate share of annual operation and maintenance costs based on total acre-foot usage of the facilities to be invoiced annually by EMWD.

5. Hold Harmless. EMWD hereby agrees to indemnify and hold RCWD and EVMWD harmless from any and all claims for damage to property or injuries to persons arising by reason of or in any manner connected with the construction of the Project performed by EMWD or EMWD's contractor, personnel or equipment. Such indemnification shall include attorneys' fees and court costs. EMWD shall comply with all applicable laws regarding the construction of public works including but not limited to Labor code requirements pertaining to prevailing wages.

6. Binding Provision. This Memorandum of Understanding is binding of the representatives, successors and assigns of the Parties hereto.

7. Entire Understanding. This instrument constitutes the entire understanding of the Parties as to the subject matter hereof and supersedes and completely extinguishes all prior understandings or agreements between the Parties. This Memorandum of Understanding shall not be amended unless in writing executed by the Parties.

IN WITNESS WHEREOF, the Parties hereto have executed this Memorandum of Understanding as of the date first above written.

RANCHO CALIFORNIA WATER DISTRICT

By: 
Brian J. Brady, General Manager

Dated: 7/6/04

ELSINORE VALLEY MUNICIPAL WATER DISTRICT

By: _____
Ronald Young, General Manager

Dated: _____

4. Maintenance and Operational Expenses. RCWD and EVMWD agree to pay their proportionate share of annual operation and maintenance costs based on total acre-foot usage of the facilities to be invoiced annually by EMWD.

5. Hold Harmless. EMWD hereby agrees to indemnify and hold RCWD and EVMWD harmless from any and all claims for damage to property or injuries to persons arising by reason of or in any manner connected with the construction of the Project performed by EMWD or EMWD's contractor, personnel or equipment. Such indemnification shall include attorneys' fees and court costs. EMWD shall comply with all applicable laws regarding the construction of public works including but not limited to Labor code requirements pertaining to prevailing wages.

6. Binding Provision. This Memorandum of Understanding is binding of the representatives, successors and assigns of the Parties hereto.

7. Entire Understanding. This instrument constitutes the entire understanding of the Parties as to the subject matter hereof and supersedes and completely extinguishes all prior understandings or agreements between the Parties. This Memorandum of Understanding shall not be amended unless in writing executed by the Parties.

IN WITNESS WHEREOF, the Parties hereto have executed this Memorandum of Understanding as of the date first above written.

RANCHO CALIFORNIA WATER DISTRICT

By: _____
Brian J. Brady, General Manager

Dated: _____

ELSINORE VALLEY MUNICIPAL WATER DISTRICT

By: _____
Ronald Young, General Manager

Dated: 7/12/04

EASTERN MUNICIPAL WATER DISTRICT

By: 
Anthony J. Pack, General Manager

Dated: 7/14/04

AGREEMENT FOR STANDBY RECYCLED WATER CONNECTION

This Agreement is made and entered into this 15th day of May 2002, by and between EASTERN MUNICIPAL WATER DISTRICT ("Eastern") and ELSINORE VALLEY MUNICIPAL WATER DISTRICT ("Elsinore"), both public agencies created pursuant to Division 20 of the California Water Code.

RECITALS

WHEREAS, Elsinore provides tertiary treated recycled water produced from its Railroad Canyon wastewater treatment plant to serve Canyon Lake golf course and other landscape areas within portions of the City of Canyon Lake; and

WHEREAS, Elsinore would like to have an alternate standby supply of recycled water in place as a back-up to the recycled water supplies produced by their Railroad Canyon Wastewater Treatment Plant during periods when their system is down and unable to produce the supplies needed; and

WHEREAS, Eastern is willing to accommodate Elsinore's request for a standby recycled water connection to aid Elsinore during system shut-downs and other critical times when shortages occur, as and when Eastern has surplus recycled water available for sale to Elsinore in accordance with the terms and conditions contained in this Agreement.

NOW, THEREFORE, in consideration of the mutual promises and covenants herein contained, Eastern and Elsinore agree as follows:

AGREEMENT

1. Recitals. The foregoing Recitals are hereby incorporated by reference into this Agreement.
2. Term. The term of this Agreement is for a period of five (5) years from the date of execution, unless sooner terminated as provided herein, or extended by mutual written agreement by both parties.
3. Facilities Description. The project consists of the design and construction of a 12" CML&C service connection from Elsinore's Canyon Lake Treatment Plant site to Eastern's 54" Reach 4 Recycled Water Transmission Pipeline at approximately Station 489+80 and the design and construction of a 12" C-900 PVC by-pass pipeline from Eastern's 24" tertiary force main to its Reach 4 pump station all as generally shown and depicted on the drawings attached hereto as Exhibits A-1 & A-2.
4. Design, Construction, and Ownership Responsibilities

Standby Service Connection. The design of the service connection shall be completed by Elsinore, and submitted to Eastern for approval. The hot tap connection to the 54" pipeline shall be constructed by Eastern at Elsinore's expense. Elsinore or its contractor shall construct the remainder of the project. The 12" CML&C pipeline and appurtenances up to and including the meter shall be constructed in accordance with Eastern's specifications, inspected, operated, owned and maintained by Eastern. The

portion of the service connection downstream of the meter shall be inspected, operated, owned and maintained by Elsinore.

By-Pass Pipeline. Eastern or its contractor shall construct the 12" C-900 PVC by-pass pipeline, the construction cost to be shared equally between Elsinore and Eastern. Ownership, operation and maintenance of the by-pass pipeline shall be the responsibility of Eastern.

5. **Reimbursement for Eastern's Expenses.** Elsinore agrees to reimburse Eastern within thirty (30) calendar days after receipt of an invoice and supporting documentation confirming the actual construction and inspection costs incurred by Eastern.
6. **Sale of Surplus Recycled Water.** Surplus recycled water, for purposes of this Agreement, are quantities of recycled water beyond or in addition to the commitments and obligations of agreements Eastern has with customers within its boundaries.

Eastern agrees to sell to Elsinore, on an "as-available" basis, surplus recycled water subject to the terms and conditions of this Agreement and applicable rules, regulations, policies and procedures.

7. **Priority of Recycled Water Sales.** Elsinore acknowledges that agreements with Eastern's customers existing prior to the execution of this Agreement have first priority to recycled water produced by Eastern. Elsinore also acknowledges that any future recycled water customers within the boundaries of Eastern shall have priority to recycled water. All recycled water priority determinations will be made by Eastern and there is no implied guarantee of availability of surplus recycled water by Eastern to Elsinore.
8. **Scheduling of Deliveries.** Elsinore shall request deliveries of surplus recycled water by giving a minimum of 24-hours notice to Eastern's Operations System Control Department at (909) 928-3777, extension 6267. Eastern will ascertain the quantity of surplus recycled water available for sale, if any, and will make every reasonable effort to accommodate requested delivery schedules. However, it is specifically understood that Eastern cannot and does not guarantee the availability of surplus recycled water or that it will be able to accommodate the time of such delivery schedules.
9. **Purchase Price.** The price per acre foot charged by Eastern to Elsinore for tertiary dechlorinated recycled water shall be Eastern's then-in-effect Rate Schedule R-662, which is currently \$165/AF, subject to periodic adjustment.
10. **Billing.** Eastern shall be responsible for submitting billings to Elsinore for the cost of the recycled water as measured through Eastern's meter located at the terminus of Eastern's facilities. Invoices shall be due and payable within 30 days from the date of the invoice. Failure of Elsinore to make payment responsive to Eastern's billings shall constitute sufficient grounds for the cessation of water deliveries until payment in full has been received.
11. **Permits and Quality of Water.** Eastern shall be responsible for compliance with all discharge standards as required to meet Federal, State and local regulatory agencies. Eastern agrees that surplus recycled water delivered under this Agreement to Elsinore shall meet all NPDES permit requirements. Beyond (downstream from) the meter, full

responsibility, liability and accountability for the delivered water shall fall upon Elsinore. Elsinore hereby accepts full and exclusive responsibility for control and use of recycled water from the meter. Elsinore shall be fully responsible for any fines, penalties and/or legal costs as a result of Elsinore's failure to comply with any condition, term or standard required by any regulatory or policing agency for recycled water downstream of the meter, and shall defend and hold Eastern harmless from any liability in connection therewith.

12. Termination.

- A. For Convenience. Either Party shall have the right to terminate this Agreement, at any time, with no financial liability, by giving the other Party thirty (30) days written notice.
- B. For Cause. This Agreement may be terminated immediately for cause by Eastern in the event Elsinore fails to perform any of its obligations imposed upon it under the terms of this Agreement so as to be in default hereunder and fails to cure such default within ten (10) days after written notice thereof.
- C. For Reasons Beyond Eastern's Control. Eastern shall have the right to terminate this Agreement by giving Elsinore ten (10) days written notice as a result of changes to regulatory agency requirements or other conditions beyond Eastern's control.

13. Force Majeure. Notwithstanding any other provision of this Agreement, in the event Eastern is prevented from carrying out its responsibilities by reason of an act of God or other reasons beyond Eastern's control, including, but not limited to, regulatory agencies or legal actions involving environment considerations, then Eastern is relieved of its obligations and responsibilities under this Agreement.

14. Mutual Indemnification. Eastern and Elsinore, each mutually, indemnify and hold each other harmless from any and all claims, demands, causes of action, damages, costs and expenses, including attorneys fees, property damage, bodily injury, personal injury, losses or liabilities, in law or in equity, of every kind and nature to the extent that the same are the result of an error, omission or negligent act on the part of, its officers or employees, or any other person acting pursuant to its control in performing under this Agreement.

15. Attorneys' Fees. In the event of the bringing of any action or suit by and Party against the other Party arising out of this Agreement, the Party in whose favor final judgment shall be entered shall be entitled to recover from the losing Party all costs and expenses of suit, including reasonable attorneys' fees.

16. Notices. Any notice required by this Agreement to be given or delivered to any Party shall be deemed to have been received when personally delivered or mailed in the United States mail addressed as follows:

Eastern: General Manager
Eastern Municipal Water District
Post Office Box 8300
Perris, CA 92572-8300

Elsinore: General Manager
Elsinore Valley Municipal Water District
Post Office Box 3000
Elsinore, CA 92531-3000

17. Preparation of This Agreement. This Agreement shall not be construed against the Party preparing it, but shall be construed as if all Parties prepared it.
18. Purpose of Captions. Captions of Paragraphs are for convenience purposes only and are not part of this Agreement.
19. Binding Provision. This Agreement is binding of the heirs, representatives, successors and assigns of the Parties hereto.
20. Severability. If any portion of this Agreement is declared by a court of law to be invalid or unenforceable, such portions shall be deemed severed from this Agreement and the remaining parts shall remain in full effect as though such invalid or unenforceable provision had not been a part of this Agreement.
21. Amendments. This Agreement may be amended or modified only in writing signed by all of the parties.
22. Entire Agreement. This Agreement contains the entire agreement between the parties with respect to the matters provided herein.
23. Counterparts. This Agreement may be executed in counterparts, each of which shall be deemed an original.
24. Authority to Sign Agreement. The undersigned individuals hereby warrant and represent that they each have full legal authority to sign this Agreement and bind the parties hereto.

IN WITNESS WHEREOF, the Parties have caused this Agreement to be executed as of the date first above written.

ELSINORE VALLEY MUNICIPAL WATER DISTRICT

EASTERN MUNICIPAL WATER DISTRICT

By: 
Ronald E. Young, General Manager

By: 
Anthony J. Paetz, General Manager

Dated: 5/28/02

Dated: 5/15/02

ATTEST:

ATTEST:

By: _____
Terese Quintanar, Board Secretary

By: 
Mary C. White, Board Secretary

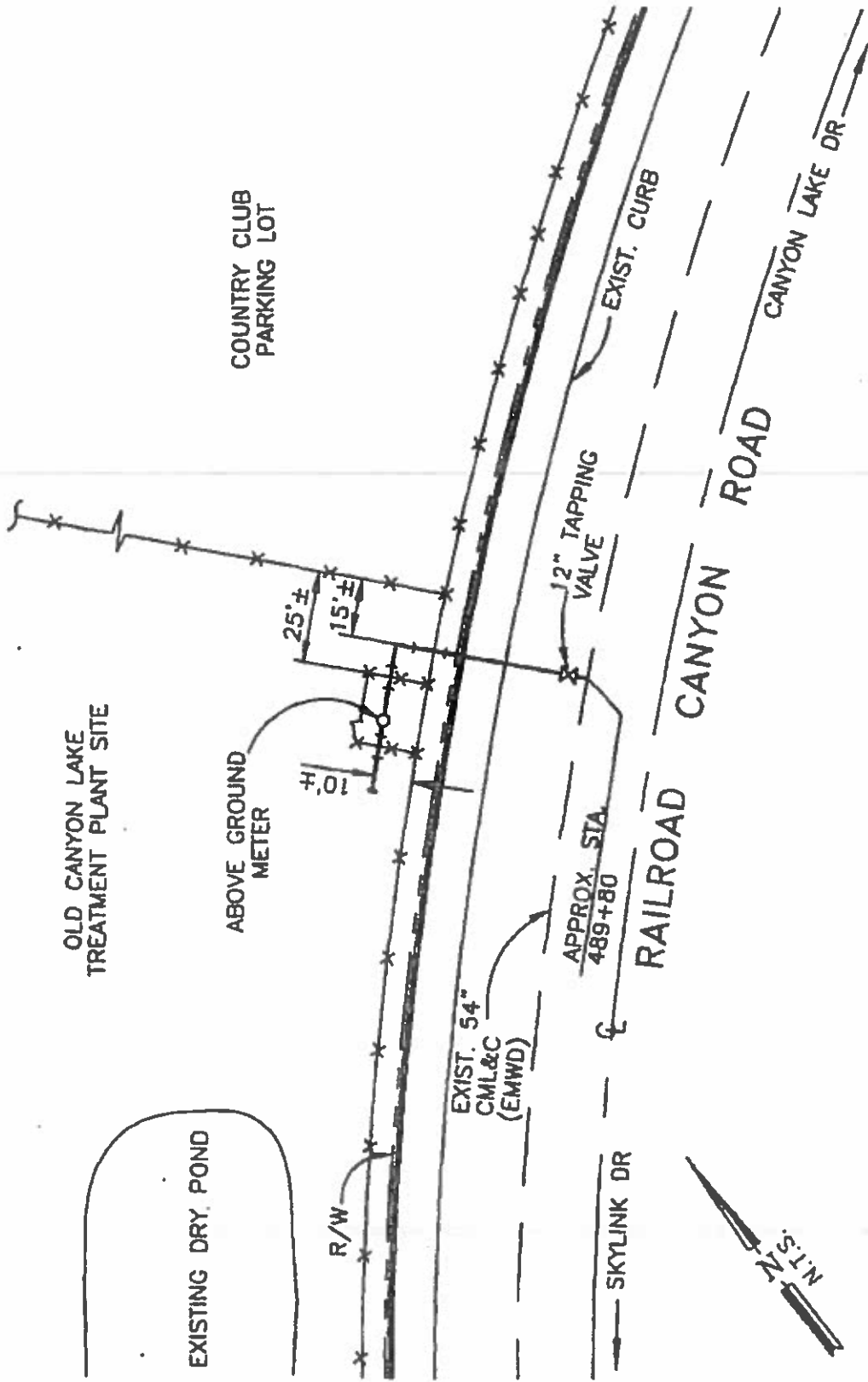

OLD CANYON LAKE
TREATMENT PLANT SITE

COUNTRY CLUB
PARKING LOT

EXISTING DRY POND

ABOVE GROUND
METER

R/W

EXIST. 54"
CML&C
(EMWD)

APPROX. STA.
489+80

12" TAPPING
VALVE

EXIST. CURB

RAILROAD
CANYON ROAD

RAILROAD
CANYON ROAD

CANYON LAKE DR



N.T.S.

RAILROAD CANYON ROAD
RECLAIMED WATER TURNOUT
FOR EVMWD

GFB-FRIBRICH
& ASSOC., INC.
CONSULTING CIVIL ENGINEERS
8928 REVERSON AVE. STE. 230
IRVINE, CA 92618
(909) 781-0811

ALL DIMENSIONS SHOWN ARE SUBJECT
TO REVISION BASED ON PENDING
SURVEY AND LOCATION OF EXISTING
UTILITIES.

DATE: 3-18-02
DRAWN BY: G.R.W.

EXHIBIT A-1

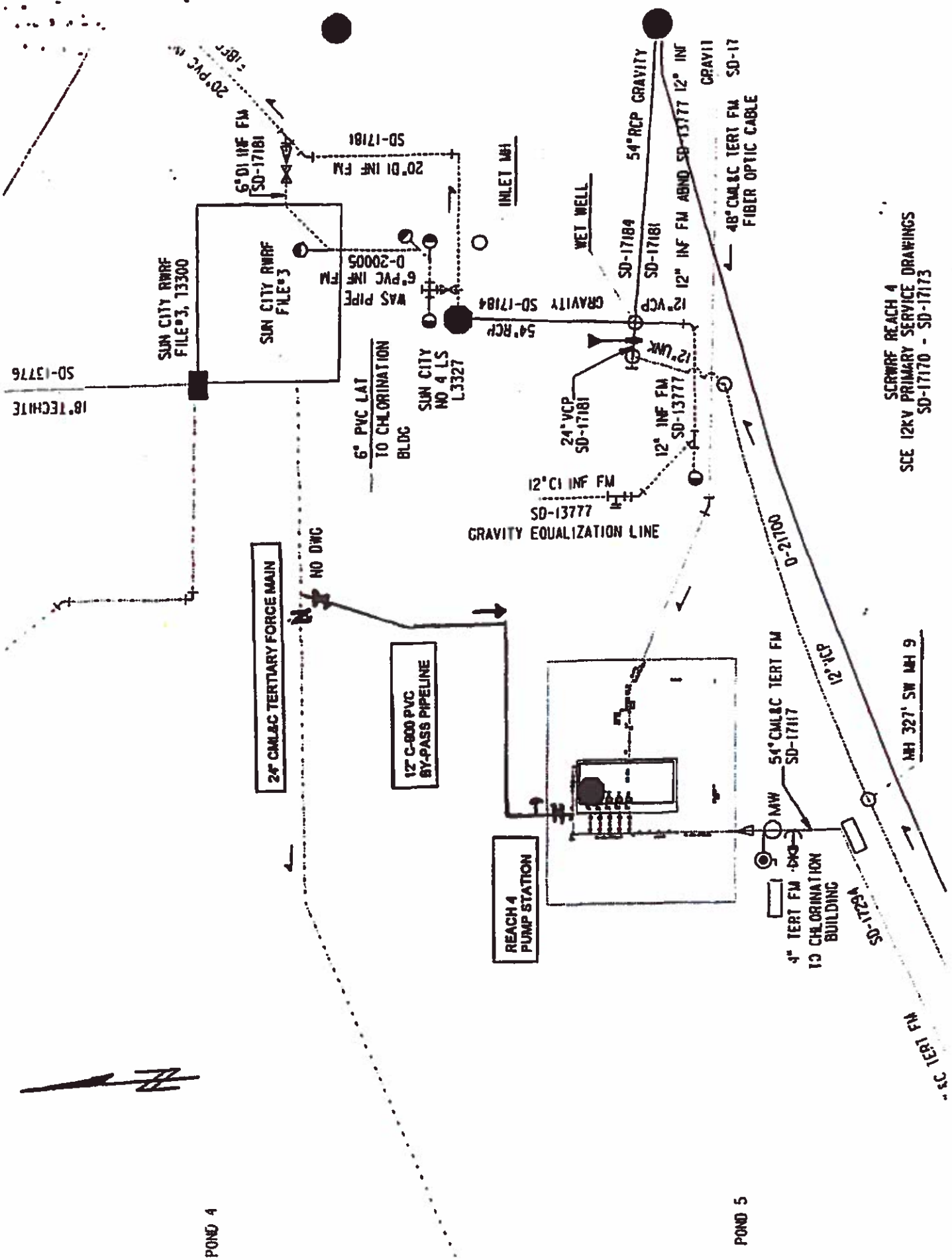

POND 4

POND 5

SCRWRF REACH 4
SCE 12KV PRIMARY SERVICE DRAWINGS
SD-17170 - SD-17173

DRY ARNDT · 12:50:27 AM · 04/12/2002

EXHIBIT A-2

Appendix C
FULL LIST OF PLANNED DEVELOPMENTS
TRACKED BY EVMWD

Appendix C

FULL LIST OF PLANNED DEVELOPMENTS TRACKED BY EVMWD

Ref #	Project Name	City/Planning Entity	Project Status	Land Use	Estimated Demand (AFY)	EDUs ⁽¹⁾
1	Alberhill Ranch Master Plan Review	Lake Elsinore	N/A	Medium Density Residential	3,412	6,092
2	Alberhill Ranch	Lake Elsinore	Inspection	Low Medium Density Residential	46	82
5	Alberhill Ridge	Lake Elsinore	Planning	Low Medium Density Residential	591	1,056
6	Saddleback Estates	Riverside County	Plan Check	Low Medium Density Residential	146	261
8	JBj Ranch	Riverside County	Planning	Low Density Residential	174	310
14	Murrieta Creek Estates - Tr. 31896	Wildomar	Planning	Low Medium Density Residential	66	117
15	Wildomar Crossing at Clinton Keith and Stable Lane	Wildomar	Plan Check	Commercial	9	16
21	Highway 74 Car Wash and Retail Center	Riverside County	Inspection	Commercial	2	4
29	NE corner Diamond Drive and Village Parkway	Lake Elsinore	Inspection	Medium Density Residential	30	54
30	Summerly Tr. 31920-15	Lake Elsinore	Inspection	Medium Density Residential	36	65
36	Monte Vista Ranch	Wildomar	Inspection	Medium Density Residential	95	170
42	Colinas Del Oro	Riverside County	N/A	Low Medium Density Residential	273	488
49	Livable Communities	Lake Elsinore	Planning	Mixed Use	10	18
51	Rancho Fortunado II	Wildomar	Inspection	Low Medium Density Residential	31	55
53	Horizon Condos Tr. 36672	Wildomar	Plan Check	High Density Residential	59	105
58	Villa Siena	Wildomar	Plan Check	High Density Residential	27	48
63	Orange Street Water and Sewer Improvements	Wildomar	Plan Check	Commercial	27	48
64	Diamond Professional Plaza	Lake Elsinore	Inspection	Mixed Use	1	2
65	Grove Park	Wildomar	Planning	Mixed Use	37	66

Ref #	Project Name	City/Planning Entity	Project Status	Land Use	Estimated Demand (AFY)	EDUs ⁽¹⁾
66	Baxter Village	Wildomar	Plan Check	Mixed Use	69	123
68	Tuscany Valley TTM 25475	Lake Elsinore	Plan Check	Medium Density Residential	95	169
69	Tuscany Crest TTM 33725	Lake Elsinore	Plan Check	Low Density Residential	65	116
73	Westpark	Wildomar	Planning	Mixed Use	54	97
75	South Shore II Tract 36567	Lake Elsinore	Planning	Low Medium Density Residential	161	287
76	Terracina Tract 36557	Lake Elsinore	Plan Check	Low Medium Density Residential	351	626
84	Canyon Hills Estates TTM 34249	Wildomar	Planning	Low Density Residential	169	302
86	Fisherman's Wharf	Lake Elsinore	N/A	Low Density Residential	28	50
87	33401 Orchard Street 3 Lot Subdivision	Wildomar	N/A	Medium Density Residential	2	3
89	Faith Bible Church	Wildomar	Inspection	Public/Institutional	36	64
92	Lake Elsinore Town Center	Lake Elsinore	Planning	Mixed Use	44	78
93	The Summit	Riverside County	N/A	Low Medium Density Residential	196	350
97	Hoist Industrial	Lake Elsinore	Planning	Industrial	85	152
99	Lakeside Pointe Apartments	Lake Elsinore	N/A	High Density Residential	84	150
100	Steven's Gardens No. 2	Riverside County	N/A	Commercial	3	5
109	Tract 33840	Wildomar	Planning	Low Medium Density Residential	8	15
110	Walmart Shopping Center, Inc.	Lake Elsinore	Inspection	Commercial	45	81
112	Tuscany Hills North	Lake Elsinore	N/A	Low Medium Density Residential	452	807
113	Circle K Riverside and Joy	Lake Elsinore	Inspection	Commercial	3	6
121	South Shore I Tract 31593	Lake Elsinore	Planning	Low Medium Density Residential	508	907
124	Kasiri Commercial Center	Wildomar	N/A	Commercial	3	6
128	Clinton Keith MSJC College Campus	Wildomar	N/A	Public/Institutional	112	200
129	Tract 32026 Water and Sewer Improvements	Riverside County	Plan Check	Low Medium Density Residential	191	341
131	Bridlewood Tr. 32206	Wildomar	Plan Check	Medium Density Residential	34	60

Ref #	Project Name	City/Planning Entity	Project Status	Land Use	Estimated Demand (AFY)	EDUs ⁽¹⁾
135	Palmilla Commercial Center	Murrieta	N/A	Commercial	9	16
139	Name Unknown	Wildomar	N/A	Medium High Density Residential	161	288
140	Name Unknown	Lake Elsinore	N/A	Hillside Residential	246	440
141	Tessera Project	Lake Elsinore	Inspection	Medium Density Residential	23	41
142	Name Unknown	Riverside County	N/A	Hillside Residential	194	347
150	Wildomar Meadows	Wildomar	Planning	Mixed Use	1,156	2,064
151	La Quinta Hotel on Dexter Avenue	Lake Elsinore	N/A	High Density Residential	35	63
152	94 Unit Apartments on Corydon and Sheets Lane	Wildomar	N/A	High Density Residential	53	94
155	Heald Street Apartment Complex - 8 Units - Sewer and Water	Lake Elsinore	N/A	High Density Residential	4	8
156	Darling-Bundy Canyon Apt. Project	Wildomar	Planning	Medium Density Residential	72	128
157	Airstream RV Dealership	Lake Elsinore	N/A	Commercial	15	27
159	North Main Street Hotel Water & Sewer	Lake Elsinore	N/A	High Density Residential	87	156
161	Camelia Townhomes	Wildomar	Planning	Medium High Density Residential	92	164
162	Name Unknown	Wildomar	N/A	Low Density Residential	3	5
163	Lakeshore Senior Apartments	Lake Elsinore	N/A	High Density Residential	68	121
164	Diamond Indoor Sports Center	Lake Elsinore	N/A	Industrial	23	41
165	Rome Hills Commercial	Riverside County	Planning	Mixed Use	71	126
167	Tract 32726 - 7 lots	Wildomar	Plan Check	Low Density Residential	4	7
170	Riverside Dr. Lake Front Hotel - Mixed Use	Lake Elsinore	Planning	Mixed Use	57	101
171	Triangle Exp Residential Car Wash	Wildomar	Planning	Commercial	3	5
172	Wildomar Shopping Mall	Wildomar	N/A	Commercial	2	3
174	Wasson Canyon Tract 37381	Lake Elsinore	Planning	Low Medium Density Residential	42	75
176	Smith Ranch Self Storage	Wildomar	Inspection	Industrial	7	13
178	Sunbelt Rentals	Wildomar	Planning	Industrial	2	4
179	The Cottages at Mission	Lake Elsinore	Inspection	Medium Density Residential	80	143

Ref #	Project Name	City/Planning Entity	Project Status	Land Use	Estimated Demand (AFY)	EDUs ⁽¹⁾
180	Railroad Canyon Mixed-Use	Lake Elsinore	N/A	Mixed Use	39	71
181	Artisan Alley	Lake Elsinore	N/A	Commercial	29	51
182	Lake Front Village Mixed Use Project	Lake Elsinore	N/A	Mixed Use	258	460
183	Starlight Meadows	Wildomar	Inspection	Low Medium Density Residential	60	108
184	Tract 32035	Wildomar	Plan Check	Low Medium Density Residential	27	49
185	Lakeview Manor	Lake Elsinore	N/A	High Density Residential	58	104
187	Greenspring Hotel	Lake Elsinore	N/A	High Density Residential	49	87
188	RV Ready RV Sales	Lake Elsinore	N/A	Industrial	2	4
189	Running Deer	Lake Elsinore	Inspection	Low Medium Density Residential	54	96
192	La Laguna RV Residentialort	Lake Elsinore	Inspection	Open Space	184	328
194	Roadrunner Park Bathroom	Canyon Lake	Plan Check	Open Space	1	2
196	Lake Elsinore Assisted Living	Lake Elsinore	N/A	High Density Residential	37	66
197	Atshan Residentialidence	Lake Elsinore	N/A	Low Density Residential	0.2	0
198	Brent Industrial Building	Wildomar	N/A	Industrial	4	6
199	Lake and I-15 Gas Station	Lake Elsinore	N/A	Industrial	8	13
200	Markou Palomar Condo (12-15 Unit)	Wildomar	N/A	High Density Residential	8	15
201	Elm Street Container Home	Lake Elsinore	N/A	High Density Residential	3	5
202	Grand Avenue Subdivision - 11 Lots (City of Wildomar)	Wildomar	N/A	Low Density Residential	6	11
203	Silverleaf Motors	Lake Elsinore	N/A	Commercial	3	6
204	Lake Elsinore Travel Center	Lake Elsinore	Plan Check	Commercial	5	9
205	Circle K (Nichols Town Center)	Lake Elsinore	N/A	Commercial	15	28
206	Lake Elsinore Commercial	Lake Elsinore	Planning	Mixed Use	25	44
207	Sky Memorial Center	Lake Elsinore	N/A	Commercial	13	24
209	Wildomar Sites	Wildomar	N/A	Low Medium Density Residential	5	9
211	Commercial Mixed-Use - New Elsinore 43	Lake Elsinore	N/A	Mixed Use	83	148

Ref #	Project Name	City/Planning Entity	Project Status	Land Use	Estimated Demand (AFY)	EDUs ⁽¹⁾
212	Home Sweet Home M-HD Residential	Riverside County	Planning	Medium High Density Residential	33	59
213	Vantage Auctions	Lake Elsinore	Plan Check	Industrial	21	37
214	Canyon Hills Marketplace, Pad 8	Lake Elsinore	Inspection	Commercial	2	4
215	Collier Honda Dealership	Lake Elsinore	Plan Check	Commercial	19	33
216	Baxter & I-15 Mixed Use Project	Wildomar	Planning	Mixed Use	47	84
217	Bundy Canyon Subdivision	Wildomar	N/A	Low Medium Density Residential	35	63
218	Summerly Tract 31920-17	Lake Elsinore	Inspection	Medium Density Residential	36	65
219	Summerly Tract 31920-18	Lake Elsinore	Inspection	Medium Density Residential	32	57
220	Summerly Tract 31920-19	Lake Elsinore	Inspection	Medium Density Residential	30	53
221	Ortiz Apartments	Lake Elsinore	Planning	High Density Residential	3	5
222	Dollar General - Highway 74 and Richard Street	Riverside County	N/A	Commercial	7	12
223	Dollar General - Grand Avenue	Riverside County	N/A	Commercial	5	9
224	Kumar Convenience Center	Lake Elsinore	Plan Check	Commercial	2	4
226	Tract 36115-1 PA 32	Lake Elsinore	N/A	Low Medium Density Residential	44	78
228	Clinton Keith Village Grocery Outlet	Wildomar	Inspection	Commercial	14	25
230	Temescal Valley Project	Riverside County	N/A	Medium High Density Residential	80	142
231	Lake Elsinore Travel Center	Lake Elsinore	Inspection	High Density Residential	45	81
232	Monte Vista II	Wildomar	Plan Check	Mixed Use	72	128
233	Prielipp Apartments	Wildomar	Planning	Mixed Use	38	69
234	Kumar Commercial Center	Wildomar	N/A	Commercial	7	13
236	Imperial Stations	Lake Elsinore	N/A	Commercial	5	8
237	Wild Omar's Zoo	Wildomar	N/A	Mixed Use	22	39
238	Marriott Hotel	Lake Elsinore	N/A	High Density Residential	76	135
240	New Ventu Residential Apartments	Lake Elsinore	N/A	High Density Residential	3	6
241	Summerly Tr. 31920-21 Water and Sewer	Lake Elsinore	Inspection	Medium Density Residential	32	57

Ref #	Project Name	City/Planning Entity	Project Status	Land Use	Estimated Demand (AFY)	EDUs ⁽¹⁾
242	Ortega Avenue and Grand Avenue Mixed-Use Project	Lake Elsinore	Planning	Mixed Use	24	43
244	Highway 74 Self Storage	Riverside County	Plan Check	Industrial	4	7
245	Summerly Tr. 31920-22	Lake Elsinore	Inspection	Medium Density Residential	27	48
247	Hotel at Oak Creek Shopping Center	Wildomar	Planning	High Density Residential	57	102
249	Viscaya Tr. 32008	Lake Elsinore	Planning	High Density Residential	4	8
250	Simple Simon, LLC	Lake Elsinore	Plan Check	Commercial	7	12
252	Harvest of Lake Elsinore	Lake Elsinore	Planning	Industrial	0.3	1
253	Summerly	Lake Elsinore	Inspection	Medium High Density Residential	57	101
254	NexxGen Project	Wildomar	Planning	Low Density Residential	4	8
255	Alberhill Elementary School	Lake Elsinore	Inspection	Public/Institutional	15	26
263	Vista Ortega Apartments	Lake Elsinore	Planning	Low Medium Density Residential	9	16
264	Oak Springs Ranch Phase 2	Wildomar	Planning	High Density Residential	37	65
265	Summerly	Lake Elsinore	Inspection	Medium High Density Residential	34	60
266	Central Street Plot Plan	Wildomar	Planning	Business Park	0.2	0
268	Summerly Tract 31920-23	Lake Elsinore	Inspection	Medium High Density Residential	43	77
269	Silverleaf Motors	Lake Elsinore	Planning	Commercial	1	1
270	Won Meditation/Retreat Center	Wildomar	Planning	Commercial	57	101
271	Jack in the Box El Toro	Lake Elsinore	Planning	Commercial	5	8
272	Central Avenue and Ardenwood Way Gas Station and Convenience Store	Riverside County	Planning	Commercial	4	7
273	Tru-Sports 17938 Collier Avenue	Lake Elsinore	Planning	Industrial	3	5
274	The Lakeview Plaza	Lake Elsinore	Planning	Commercial	11	19
275	Oak Creek Canyon	Lake Elsinore	Planning	Mixed Use	2	4
276	Highway 74 Business Park	Riverside County	Plan Check	Business Park	4	7
279	Westlake Offsite Water	Lake Elsinore	Inspection	Medium Density Residential	50	90
280	21-115 - SFR Waterline Extension	Riverside County	Planning	Low Density Residential	28	50

Ref #	Project Name	City/Planning Entity	Project Status	Land Use	Estimated Demand (AFY)	EDUs ⁽¹⁾
282	Corydon II	Lake Elsinore	Planning	Industrial	3	5
283	Hadley's Place	Lake Elsinore	Planning	Industrial	1	3
284	Jean Hayman Site Phase I	Wildomar	Planning	Medium Density Residential	28	50
286	Wildomar Shooting Range	Wildomar	Plan Check	Industrial	2	3
287	Ramiro Residentialidence	Lake Elsinore	Planning	Medium Density Residential	1	1
288	Mosqueda Residentialidence	Lake Elsinore	Planning	High Density Residential	0.5	1
289	Mountain and Lake Street	Lake Elsinore	Planning	Commercial	15	28
291	Leicester Waterline	Wildomar	Plan Check	Low Density Residential	0.3	1
292	DG- Lake Elsinore	Riverside County	Inspection	Commercial	3	6
293	Canyon Hills Phase 7 Landscape	Lake Elsinore	Inspection	Open Space	21	38
294	Nichols Ranch Tract 37305	Lake Elsinore	Inspection	Low Density Residential	97	173
295	Garner Road	Riverside County	Inspection	Medium Density Residential	0.3	1
299	Cordero Residence	Lake Elsinore	Planning	High Density Residential	1	1
300	Perris Senior Apartments	Lake Elsinore	Planning	High Density Residential	3	5
301	Summerly Storm Water Pump Station	Lake Elsinore	Inspection	Vacant	0	0
303	TPM 37773	Lake Elsinore	Planning	Industrial	7	12
304	Chevron Gas Station Remodel	Lake Elsinore	Planning	Commercial	2	3
305	Sycamore Creek Marketplace	Riverside County	Planning	Commercial	29	51
310	Gas Station, Convenience Store and Carwash	Lake Elsinore	Inspection	Commercial	3	5
311	Arturo and Nathan Luna	Wildomar	Planning	Low Density Residential	5	9
312	Wagners Run	Riverside County	Planning	Low Medium Density Residential	4	7
313	1589 Mill Street	Lake Elsinore	Planning	Medium Density Residential	10	19
314	Lake Elsinore Commerce Center	Lake Elsinore	Planning	Commercial	662	1,181
317	Golcheh Group Commercial Use	Lake Elsinore	Planning	Commercial	16	29
318	Wasson Canyon Tract 37382	Lake Elsinore	Planning	Low Medium Density Residential	123	220

Ref #	Project Name	City/Planning Entity	Project Status	Land Use	Estimated Demand (AFY)	EDUs ⁽¹⁾
319	East Lake Villas	Lake Elsinore	Planning	Mixed Use	21	37
320	Cannabis Property	Lake Elsinore	Planning	Commercial	2	3
322	Los Compadres	Lake Elsinore	Plan Check	Commercial	1	2
324	North Elsinore Industrial Park	Lake Elsinore	Planning	Industrial	5	9
325	187 Chestnut Avenue	Lake Elsinore	Inspection	Medium Density Residential	2	3
326	17393 Grand Avenue Cannabis Retail	Riverside County	Planning	Mixed Use	1	1
328	143 South Terra Cotta Road	Lake Elsinore	Inspection	Low Medium Density Residential	0.4	1
329	22200 Canyon Club Drive	Canyon Lake	Plan Check	Public/Institutional	12	22
330	Renaissance Ranch Commerce Center	Riverside County	Planning	Business Park	162	289
331	407 West Sumner Avenue	Lake Elsinore	Inspection	Low Medium Density Residential	0.4	1
332	Pacific Coral	Lake Elsinore	Planning	Low Medium Density Residential	98	174
333	Herbert Nursery	Riverside County	Planning	Commercial	13	23
334	Tommy's Car Wash	Lake Elsinore	Planning	Commercial	3	5
335	APN 374-101-003 Water Line Extension	Lake Elsinore	Planning	Low Medium Density Residential	1	1
336	APN 378-183-024 SFH	Lake Elsinore	Planning	Low Density Residential	0.3	1
338	Bahia Village	Riverside County	Planning	Low Medium Density Residential	21	38
339	Granite Street - Sewer Line Extension	Lake Elsinore	Planning	Medium Density Residential	1	1
340	APN 345-220-067 - Water Line Extension	Riverside County	Planning	Medium Density Residential	3	4
341	SEC Dexter and Allan	Lake Elsinore	Planning	Commercial	7	12
342	Palomar Road SFR	Wildomar	Inspection	Medium High Density Residential	3	5
343	APN 347-130-025- Cannabis Facility	Riverside County	Planning	Commercial	3	5
344	Mi Familia Tattoo Shop	Lake Elsinore	Planning	Commercial	2	3
345	Tr. 33140	Lake Elsinore	Planning	Low Medium Density Residential	163	292
346	PAR APN 370-080-024 Modular Offices	Lake Elsinore	Plan Check	Business Park	1	1
347	Starbucks	Lake Elsinore	Plan Check	Commercial	3	6
348	CAFH Order of Wildomar	Lake Elsinore	Planning	Low Density Residential	0.2	0

Ref #	Project Name	City/Planning Entity	Project Status	Land Use	Estimated Demand (AFY)	EDUs ⁽¹⁾
349	Pennington Industrial	Lake Elsinore	Inspection	Industrial	4	7
350	183 South Chestnut Street APN 373-152-016	Lake Elsinore	Inspection	Medium Density Residential	0.5	1
351	18565 Grand Avenue	Riverside County	Plan Check	Low Medium Density Residential	2	4
352	1515 West Sumner Avenue Sewer Extension	Lake Elsinore	Plan Check	Low Medium Density Residential	0.4	1
353	Store America Self Storage	Wildomar	Planning	Industrial	3	6
354	Sunny Lane SFR APN 387-060-004	Riverside County	Planning	Low Medium Density Residential	1	1
355	Westridge Condos	Lake Elsinore	Inspection	Medium Density Residential	34	60
356	Rivera Towing Flint Street Waterline Extension	Lake Elsinore	Inspection	High Density Residential	1	2
357	Temescal Canyon Mini Storage	Riverside County	Inspection	Industrial	6	10
358	Lakeside (TriPoint Homes)	Lake Elsinore	Planning	Medium High Density Residential	94	168
359	Lake Street RV Storage	Lake Elsinore	Plan Check	Industrial	15	27
360	Ortega Plaza	Lake Elsinore	Planning	Commercial	15	27
361	Echo Highland Tract 32585	Riverside County	Plan Check	Low Medium Density Residential	91	163
362	SFR Manufactured Homes	Wildomar	Plan Check	Low Density Residential	3	6
363	TTM 37916 SFR	Murrieta	Planning	Low Density Residential	3	5
364	Nichols Industrial Center	Lake Elsinore	Planning	Industrial	58	104
365	Pacific Hydrotech Corporation	Riverside County	Planning	Industrial	15	28
366	Spyglass Tract 35337	Lake Elsinore	Planning	Low Medium Density Residential	579	1,034
367	La Strata Tract 32077	Lake Elsinore	Planning	Low Medium Density Residential	72	128
368	ProWest Main	Wildomar	Planning	Commercial	7	13
369	Inland Valley Medical Center	Wildomar	Planning	Public/Institutional	28	51
370	Rancon Medical & Education Center	Wildomar	Planning	Commercial	76	136
371	The Grove (T36673)	Wildomar	Planning	High Density Residential	22	39
372	Cholico Residence	Riverside County	Planning	Low Density Residential	1	1
373	Cannabis Property	Lake Elsinore	Plan Check	Commercial	4	7

Ref #	Project Name	City/Planning Entity	Project Status	Land Use	Estimated Demand (AFY)	EDUs ⁽¹⁾
374	760 Park Avenue Waterline Extension	Lake Elsinore	Plan Check	Medium Density Residential	0.4	1
375	Alberhill Ranch Tract 28214-9 to 17	Lake Elsinore	Plan Check	Low Medium Density Residential	290	518
376	Sunny Express Carwash	Lake Elsinore	Planning	Commercial	6	11
377	Commercial Remodel 18570 Collier	Lake Elsinore	Plan Check	Commercial	2	3
378	Popeyes	Wildomar	Planning	Commercial	3	6
379	10 Single Family Homes	Wildomar	Planning	Medium Density Residential	6	10
380	Sage/Investco Mixed-Use	Wildomar	Planning	Mixed Use	19	34
381	Espinoza Residential	Lake Elsinore	Planning	Low Medium Density Residential	1	2
382	374-081-002 Line Extension	Lake Elsinore	N/A	Low Medium Density Residential	0.5	1
383	381-100-021 Parcel Subdivision	Riverside County	Planning	Low Medium Density Residential	10	17
384	Sierra Park North Development	Canyon Lake	Plan Check	Medium Density Residential	13	23
385	315 North Lewis Street Sewer Lateral	Lake Elsinore	Inspection	Low Medium Density Residential	0.5	1
386	Cannabis Cultivation Distribution Retail	Riverside County	N/A	Commercial	8	14
387	Riley Apartments	Lake Elsinore	Plan Check	High Density Residential	1	2
388	Flint St 4 Plex	Lake Elsinore	N/A	High Density Residential	2	4
389	18492 Dexter Building Division	Lake Elsinore	N/A	Commercial	3	5
390	Brown Street New SFR	Lake Elsinore	N/A	Low Density Residential	0.2	0
391	Coffee and Bakery	Lake Elsinore	N/A	Commercial	5	8
392	Cannabis Cultivation and Retail Facility	Lake Elsinore	N/A	Commercial	1	2
393	Lakeland Village Senior Complex	Riverside County	Planning	Low Medium Density Residential	12	21
394	PAR - 21-0119 - TPM 36476 Proposal	Wildomar	Planning	Medium Density Residential	26	46
395	PAR - 21-0108 - Chiquito Battery Storage Facility	Wildomar	Planning	Industrial	1	3
396	SFR 379-202-001 31131 Illinois Street	Lake Elsinore	N/A	Medium Density Residential	0.3	0
397	Pottery Apartments	Lake Elsinore	N/A	Medium Density Residential	3	6
398	Commercial Retail Center	Riverside County	N/A	Commercial	6	11

Ref #	Project Name	City/Planning Entity	Project Status	Land Use	Estimated Demand (AFY)	EDUs ⁽¹⁾
400	Reyes Single Family Residence	Lake Elsinore	Planning	Low Medium Density Residential	1	1
401	Tres Lagos Apartments	Wildomar	N/A	High Density Residential	29	53
402	Central Grocery and Retail	Lake Elsinore	Planning	Commercial	23	41
403	Miguels Jr DCDA Service Removal	Lake Elsinore	N/A	Commercial	2	3
404	SFR APN 378-181-080	Lake Elsinore	N/A	Low Density Residential	0.2	0
405	SFR APN 383-020-001	Riverside County	N/A	Low Medium Density Residential	150	267
406	350-Home Single Family Development	Lake Elsinore	N/A	Hillside Residential	140	249
407	SFR 32657 Wildomar Trail 376-042-011	Wildomar	N/A	Medium Density Residential	1	1
408	SFR 365-270-053	Wildomar	Planning	Open Space	76	136
409	373-082-037 Townhomes	Lake Elsinore	N/A	Mixed Use	0.2	0
410	22261 Walnut Street Sewer Lateral	Wildomar	Inspection	Low Density Residential	1	2
411	Empire Design Group Backflow Upgrade	Lake Elsinore	N/A	Commercial	1	1
412	Graham Street Sewer Lateral Repair	Lake Elsinore	Inspection	Mixed Use	0.4	1
413	375-250-024 Line Extension	Lake Elsinore	Planning	Medium Density Residential	1	2
414	32985 Serena Way	Lake Elsinore	Inspection	Mixed Use	1	1
415	1505 West Sumner Avenue Sewer Lateral	Lake Elsinore	Inspection	Low Medium Density Residential	0.4	1
416	Tr. 36952, Wildomar Ridge	Wildomar	Plan Check	Medium Density Residential	28	49
417	Manning Street Water Line Extension	Lake Elsinore	Planning	Hillside Residential	0.1	0
418	Sierra Park North Bathroom	Canyon Lake	Plan Check	Low Density Residential	0.2	0
419	Franklin and Miramar Single Family Residence	Lake Elsinore	Planning	Very Low Density Residential	0.4	1
420	16465 Joy Street 6-Inch Sewer Lateral Repair	Lake Elsinore	Inspection	Medium Density Residential	3	5
421	389-290-028 Water Line Extension	Lake Elsinore	Planning	Low Medium Density Residential	5	9
422	SFR - APN - 345-220-044	Riverside County	Planning	Low Density Residential	5	8
423	North Wildomar Retail Center	Wildomar	Planning	Commercial	4	7
424	Central Wildomar Retail Center	Wildomar	Planning	Commercial	2	4

Ref #	Project Name	City/Planning Entity	Project Status	Land Use	Estimated Demand (AFY)	EDUs ⁽¹⁾
427	Corydon 3	Lake Elsinore	Planning	Low Density Residential	4	8
428	SFR - 375-323-006	Lake Elsinore	Planning	Low Medium Density Residential	0.2	0
429	Saint Frances of Rome Recycled Water	Wildomar	Inspection	Outside	0	0
432	City of Wildomar 27 Acre Park	Wildomar	Planning	Medium Density Residential	67	120
433	317 North Lewis Street Sewer Lateral Connection	Lake Elsinore	Inspection	Low Medium Density Residential	0.5	1
445	Corydon and Grand Mixed Use - APN 370-171-015	Wildomar	Planning	Commercial	21	37
446	PA 2021-22 APN 377-190-002	Lake Elsinore	Planning	Commercial	2	4
447	Summer Sage Way PAR APN 367-130-036	Wildomar	Planning	Open Space	3	5
449	PAR - Ou Residence - APN - 374-112-019	Lake Elsinore	Planning	Low Medium Density Residential	0.4	1
450	PA 2021-29 Industrial Project APN 377-140-028	Lake Elsinore	Planning	Industrial	7	12
454	Catt Road Retail Center	Wildomar	Planning	Commercial	7	13
455	Highway 74 Contractor Yard	Riverside County	Planning	Commercial	40	71
456	Mission Trail Animal Shelter	Wildomar	Planning	Commercial	7	13
457	Horsethief Ridge Tr. 37002	Riverside County	Plan Check	Medium Density Residential	128	229
458	Water and Sewer Extension APN 349-330-007	Riverside County	Planning	Hillside Residential	15	27
459	LE Costco Car Wash	Lake Elsinore	Planning	Commercial	7	12
460	Palmilla Bungalows Apartments	Murrieta	Planning	High Density Residential	30	54
461	34497 Cherry Street Sewer Lateral	Wildomar	Inspection	Low Density Residential	0.3	1
462	SFR APN 383-091-001	Riverside County	Planning	Low Medium Density Residential	0.3	0
463	Water Line Ext 366-130-041	Wildomar	Planning	Medium Density Residential	2	3
464	33016 Evergreen Street Sewer Lateral	Riverside County	Inspection	Medium Density Residential	0.3	1
465	America's Tire Lake Elsinore	Riverside County	Plan Check	Commercial	6	10
466	SFR APN 379-090-029 and 030	Lake Elsinore	Planning	Low Medium Density Residential	1	2

Ref #	Project Name	City/Planning Entity	Project Status	Land Use	Estimated Demand (AFY)	EDUs ⁽¹⁾
467	SFR Sewer Extension APN - 375-322-020	Lake Elsinore	Planning	Low Medium Density Residential	0.2	0
468	28603 Highway 74 Contractor Yard	Riverside County	Planning	Business Park	4	7
469	Dutch Brothers Coffee	Riverside County	Plan Check	Business Park	1	1
470	Rosetta View Estates	Lake Elsinore	Plan Check	Low Medium Density Residential	22	40
471	Fire Hydrant Relocation 29280 Central Avenue	Lake Elsinore	Inspection	Public/Institutional	1	3
472	Lakeshore Dock Installation	Lake Elsinore	Planning	Vacant	-	-
473	Aguinaga Green	Wildomar	Planning	Commercial	10	18
474	Tr. 3720 Verizon Cell Tower - Cross Hill	Canyon Lake	Planning	Industrial	2	3
475	The Cove Apartments	Lake Elsinore	Planning	High Density Residential	255	456
476	Temescal Valley Commerce Center	Riverside County	Planning	Industrial	69	124
477	Grand Avenue 6	Wildomar	Planning	Low Density Residential	3	5
478	Rosetta Ridge	Lake Elsinore	Planning	Low Medium Density Residential	43	78
479	Lakeview Apartments	Lake Elsinore	Planning	High Density Residential	81	144
481	Horsethief 5G LSub6	Riverside County	Planning	Industrial	1	1
482	Lindsay Street	Lake Elsinore	Planning	Low Medium Density Residential	0.4	1
483	30433 Chaney Street	Lake Elsinore	Planning	Low Medium Density Residential	0.3	1
484	Mission Trail Tract 043001/1	Lake Elsinore	Planning	Medium Density Residential	76	136
485	Hidden Springs Mixed Use	Wildomar	Planning	Mixed Use	313	558
486	Rosetta Canyon Apartments	Lake Elsinore	Planning	High Density Residential	150	268
487	De Palma Regional Lift Station	Riverside County	Planning	Low Medium Density Residential	7	12
488	Horsethief Zone 1601 Reservoir No. 2	Riverside County	Planning	Low Density Residential	1	1
489	Alberhill Ridge Zone 1601/1676 Pump Station	Lake Elsinore	Plan Check	Vacant	0	0
490	Tuscany Crest Temporary Sewer Lift Station	Lake Elsinore	Plan Check	Vacant	0	0
496	SFR - APN 363-273-025	Lake Elsinore	Planning	Low Medium Density Residential	1	1
497	420 North Langstaff Street Multi Family	Lake Elsinore	Planning	High Density Residential	2	4

Ref #	Project Name	City/Planning Entity	Project Status	Land Use	Estimated Demand (AFY)	EDUs ⁽¹⁾
498	Wildomar Crossings Commercial Mixed-Use	Wildomar	Planning	Commercial	12	21
499	Industrial Building APN 377-430-016	Lake Elsinore	Planning	Industrial	1	2
1275	Oak Creek Canyon	Lake Elsinore	Plan Check	Low Density Residential	154.02	275
1346	Rosetta Hills Tr. 30698	Lake Elsinore	Inspection	Low Medium Density Residential	111	199
1348	SFR Olivas APN 378-156-038, 039	Lake Elsinore	Plan Check	Medium Density Residential	25	44
1350	Thomas Residence	Lake Elsinore	Inspection	Medium Density Residential	0.5	1
1351	Corydon Gateway Commercial	Riverside County	Plan Check	Commercial	15	26
1353	Wildomar MDP Lateral C, Stage 3 Sewer Relocation	Wildomar	Plan Check	Medium Density Residential	24	42
1469	Mermack Avenue Street Improvements	Riverside County	Planning	Commercial	24	42
Total					17,899	31,959

Notes:
 (1) EDU = Equivalent Dwelling Unit. This represents the demand equal to one dwelling unit, even if the planned development does not include dwelling units. EDU demand is assumed to be 500 gpd/EDU.

Appendix D

DIURNAL PATTERNS FOR CUSTOMERS BASED ON AMI DATA

Appendix D

DIURNAL PATTERNS FOR CUSTOMERS BASED ON AMI DATA

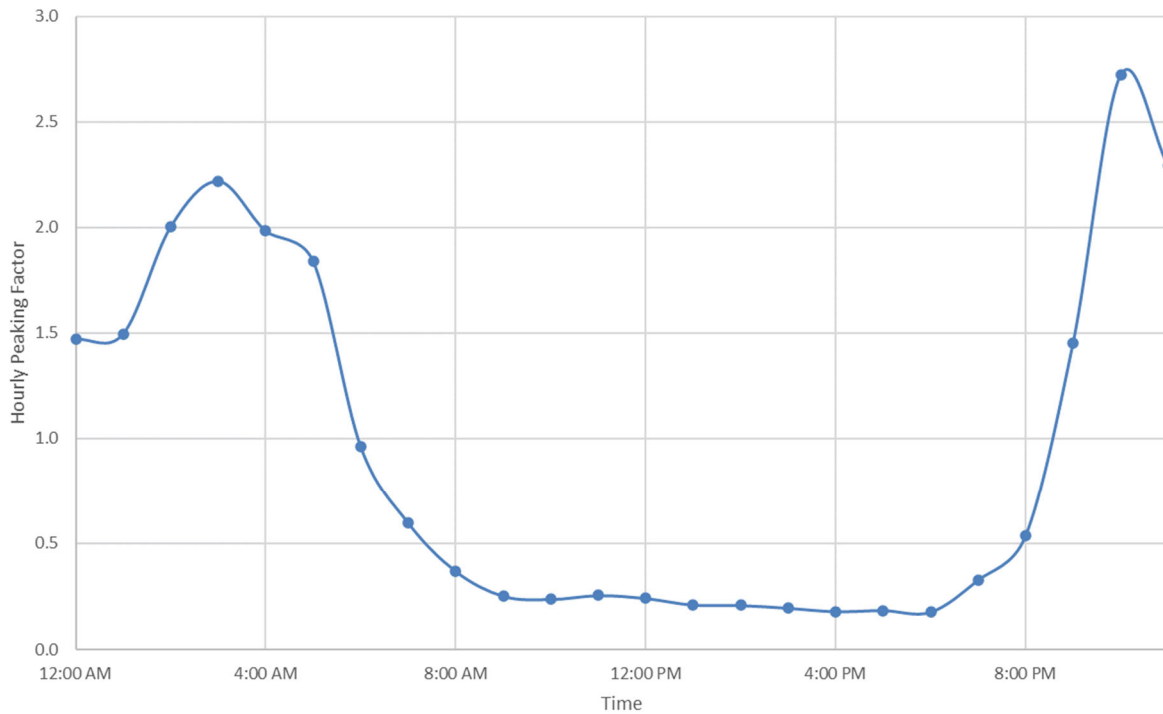

Figure D.1 Horsethief Canyon AMI Diurnal Pattern

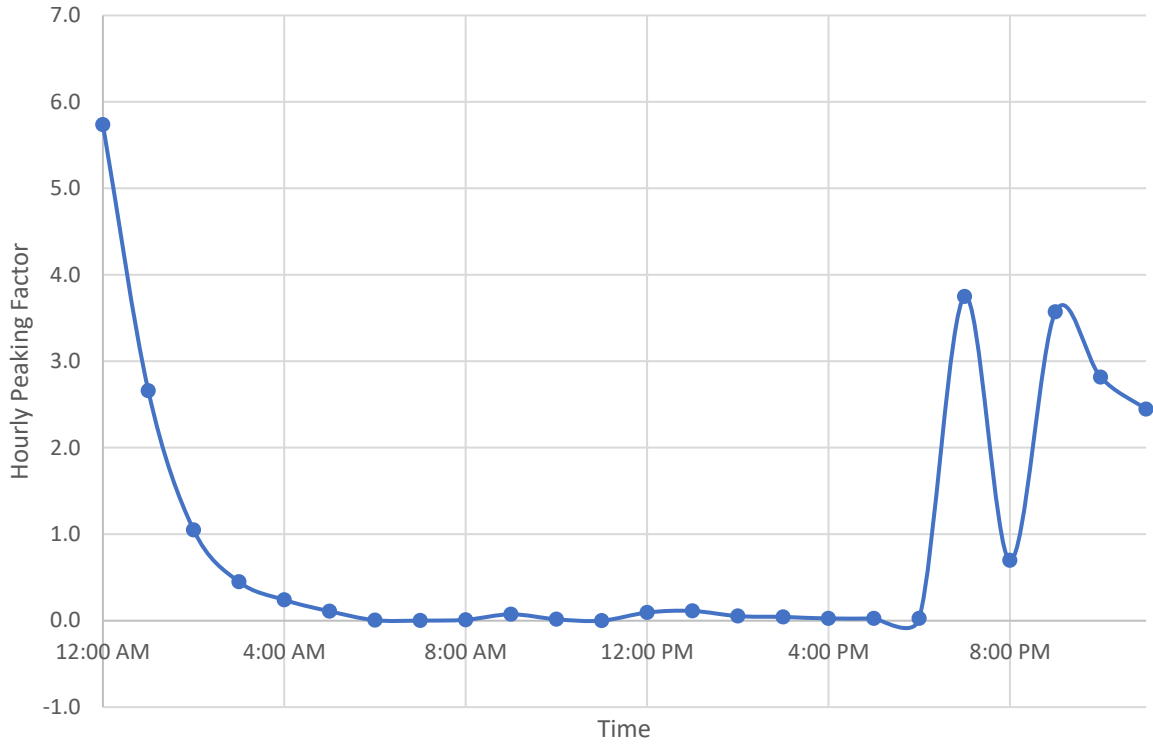

Figure D.2 Railroad Canyon WRF Ponds AMI Diurnal Pattern

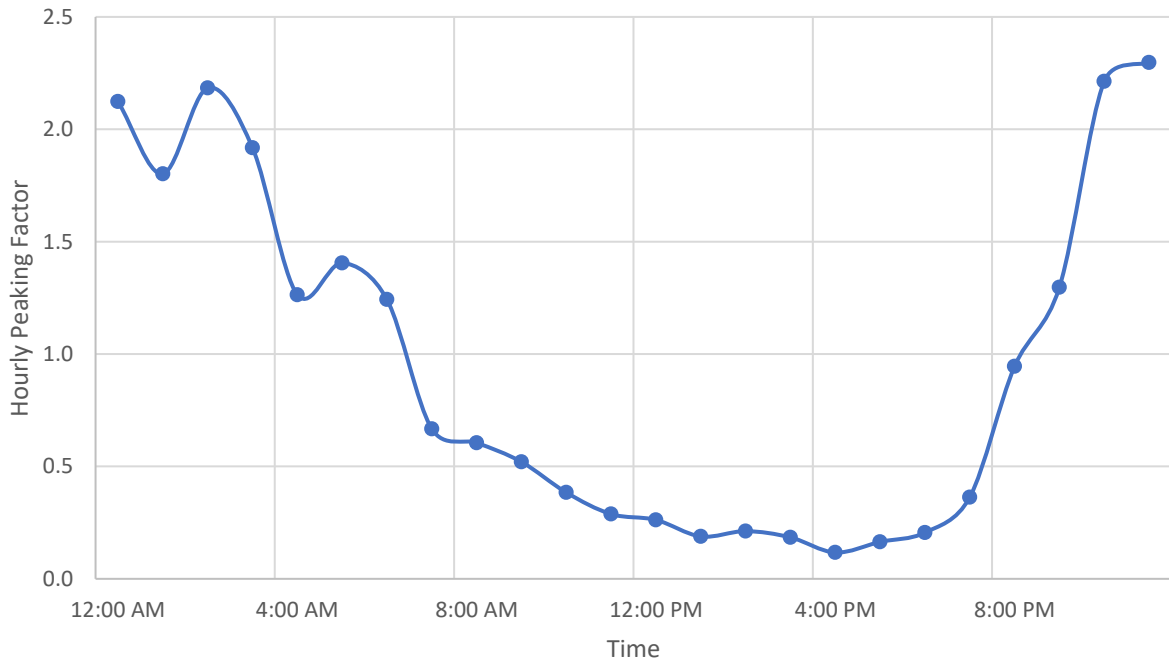

Figure D.3 Canyon Lake Golf Course AMI Diurnal Pattern

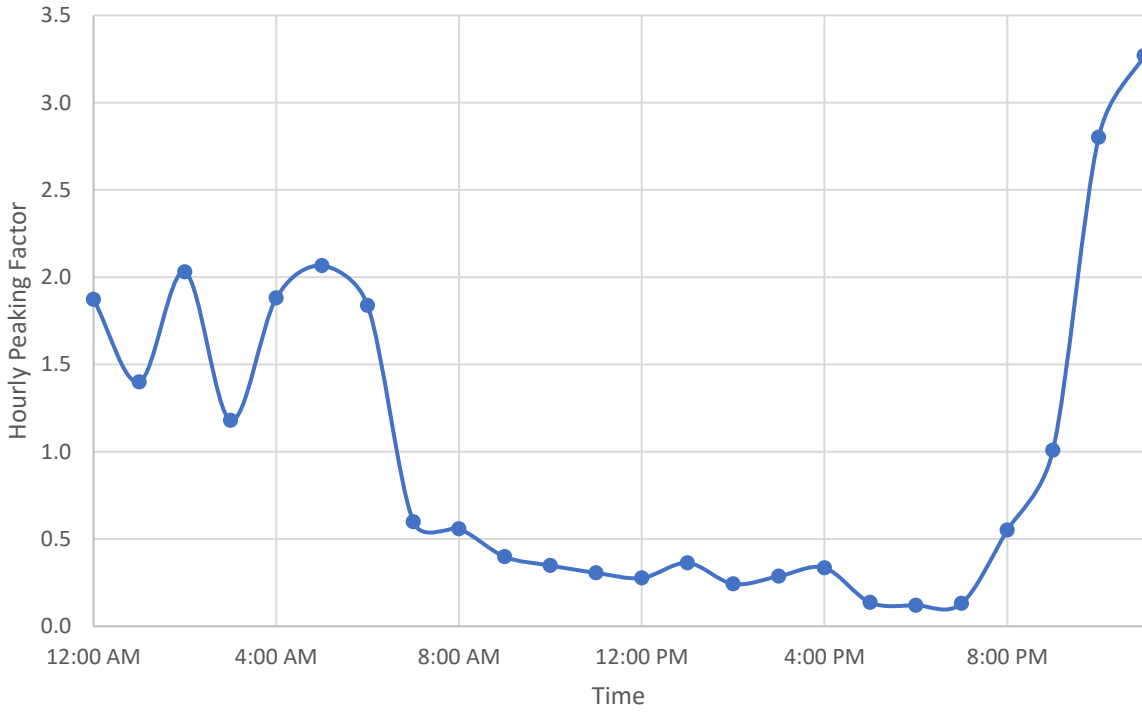

Figure D.4 Wildomar Turnout No. 1 AMI Diurnal Pattern

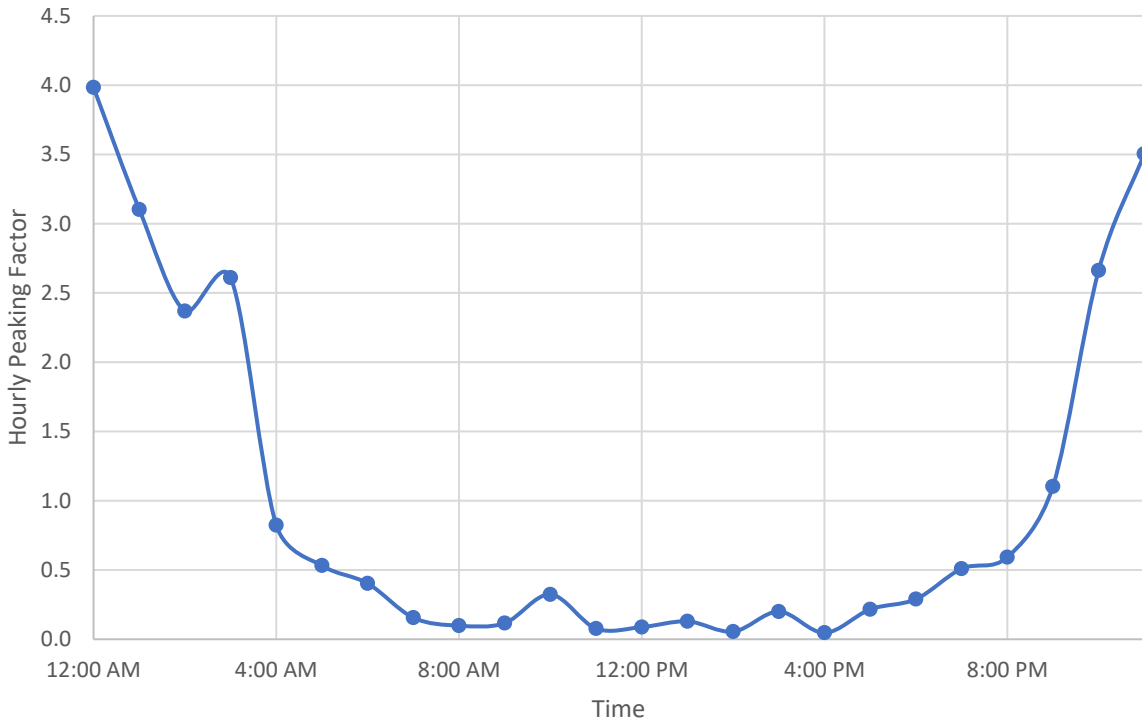

Figure D.5 Wildomar Turnout No. 2A AMI Diurnal Pattern

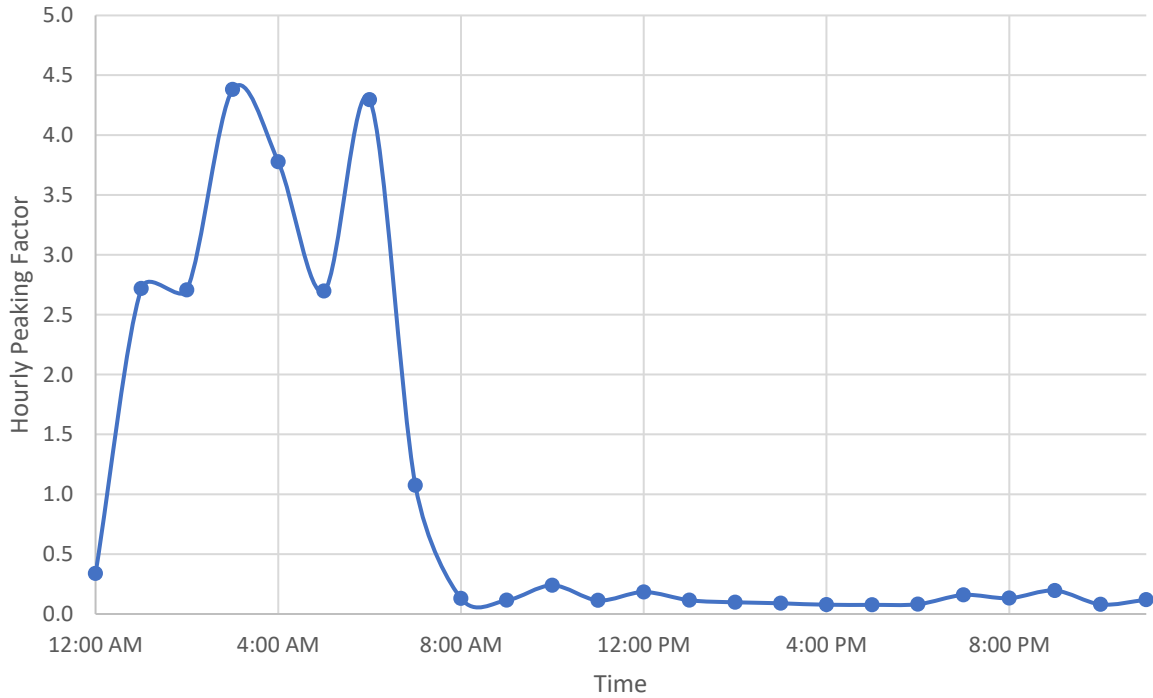

Figure D.6 Wildomar Turnout No. 2B AMI Diurnal Pattern

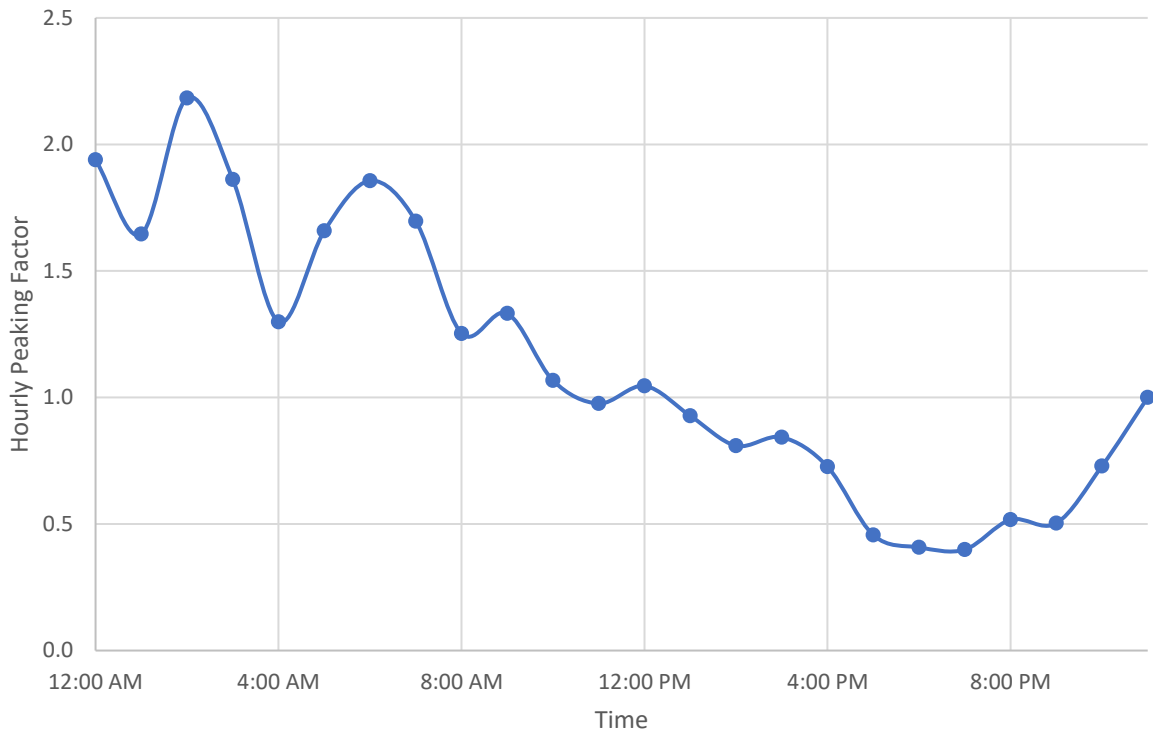

Figure D.7 Wildomar Turnout No. 5 AMI Diurnal Pattern

Appendix E
NON-POTABLE REUSE PROJECTS

Appendix E

NON-POTABLE REUSE PROJECTS

Wildomar System

The potential projects to expand the Non-Potable Reuse (NPR) system for Wildomar are identified in Chapter 8 of this Recycled Water System Master Plan. These potential Wildomar projects (pending additional supplies) are shown on Figure E.1.

The cost for these pipeline projects has been developed and are presented in Table E.1. However, these project are not included in the capital improvement plan (CIP) due to lack of supplies. Moreover, there are no booster pumps or storage tanks projects recommended for a potential Wildomar system expansion.

Table E.1 Wildomar NPR Projects Cost

Project	Total Improvement Cost (\$)
Wildomar NPR Project 1	\$ 11,800,000
Wildomar NPR Project 2	\$ 1,000,000
Wildomar NPR Project 3	\$ 200,000
Wildomar NPR Project 4	\$ 5,000,000
Wildomar NPR Project 5	\$ 2,900,000
Total Cost	\$ 20,900,000

The total cost of potential improvements for the Wildomar system is \$21 million and the detailed breakdown is presented in Appendix G. These are not included in the CIP due to lack of water supply.

Regional System

In case Elsinore Valley Municipal Water District (EVMWD) decides to not implement the indirect potable reuse (IPR) project, excess water from the Regional Water Reclamation Facility (WRF) could be used to provide non-potable water to future planned customers resulting in three pipeline projects. Although these projects are not considered a part of the CIP, this project configuration is shown on Figure E.1. and the associated estimated costs are summarized in Table E.2, while the detailed breakdown is presented in Appendix G. The expansion of the Regional NPR will also require three additional pump stations and a 1.4-million-gallon storage tank at the Regional WRF as discussed in Chapter 8. Similar to the NPR pipeline projects, these pump station and storage tank projects are not considered a part of the CIP. If implemented, these projects are recommended for construction in the 2040-2045 period.

Table E.2 Potential Regional NPR Projects Cost (In Case IPR Is Not Implemented)

Project	Total Improvement Cost (\$)
Regional NPR Pipeline Project 1	\$ 8,200,000
Regional NPR Pipeline Project 2	\$ 12,100,000
Regional NPR Pipeline Project 3	\$ 8,600,000
Pump Station at Regional WRF	\$ 13,000,000
Pump Station Along 3rd Street Northeast of Conrad Avenue	\$2,500,000
Pump Station at Baker Street	\$ 5,900,000
Storage Tank at Regional WRF	\$6,000,000
Total Cost	\$ 56,300,000

The total cost of constructing a non-potable system for the Regional System is estimated to be \$56.3 million. These projects have not been included in the CIP as IPR is the recommended use of recycled water from the Regional WRF at this time.

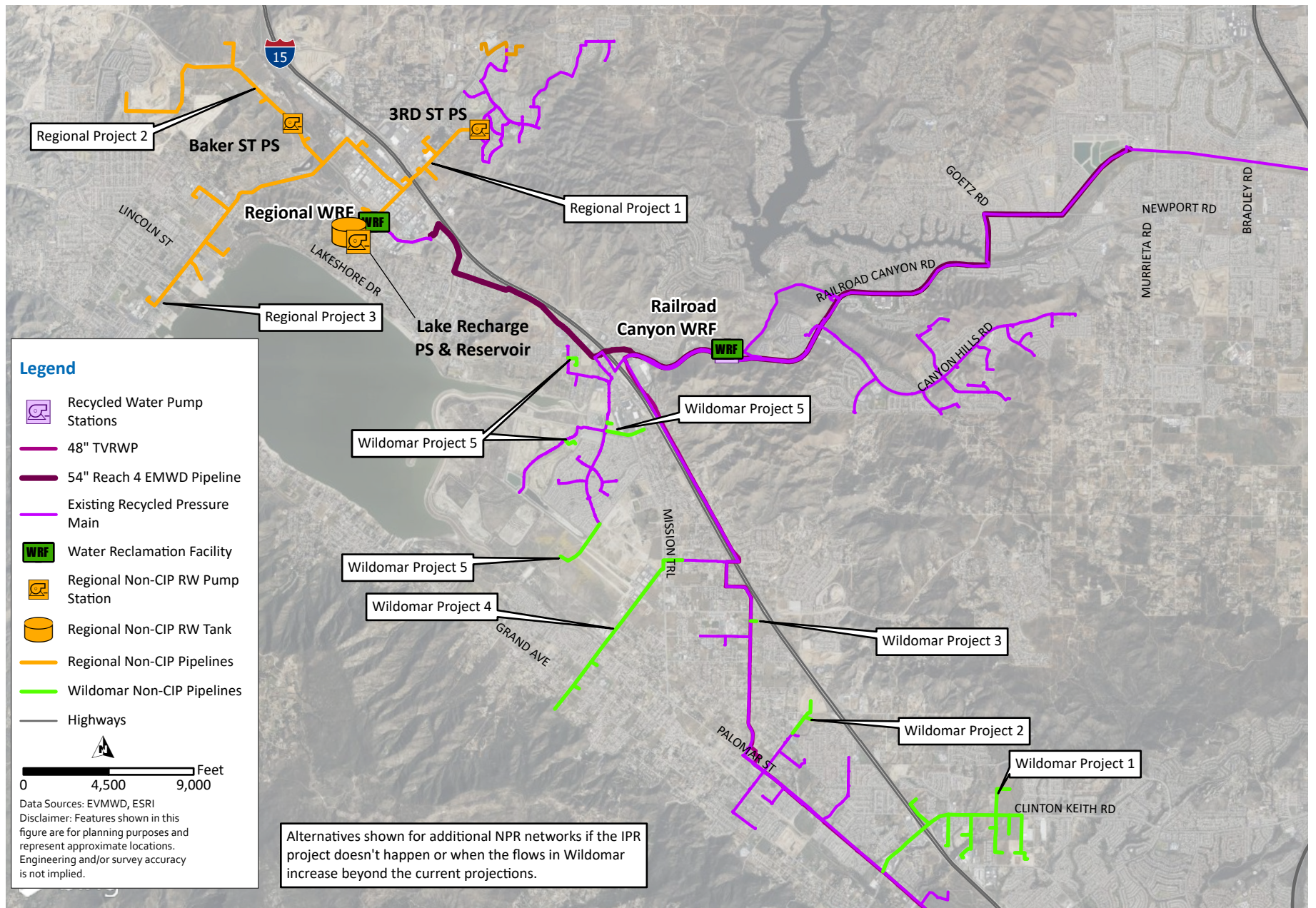

Figure E.1 Potential Projects Not included in CIP

-This Page Intentionally Left Blank-

Appendix F
CIP PROJECTS SUMMARY SHEETS

Project Number:	RWLP-1
Project Name:	Horsethief Short term new developments
System Type:	Recycled Water

Project Description:

This project includes construction of 4-inch and 6-inch pipelines for following four developments in the near-term:

1. Renaissance Ranch Commerce Center
2. JBJ Ranch
3. Saddleback Estates
4. SAM

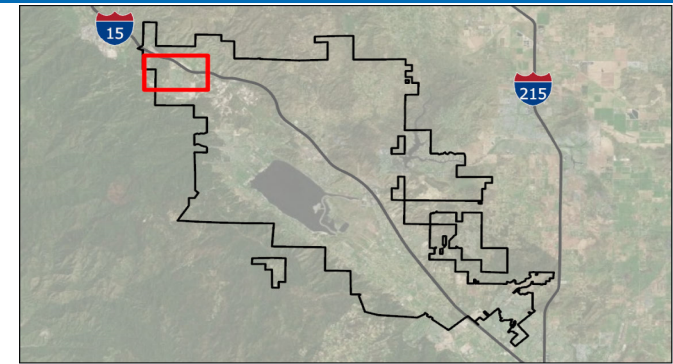

Project Details:

Project Element	Existing Diameter (in)	Proposed Diameter (in)	Replace/ New	Length (ft)	Unit Cost ⁽¹⁾ (\$/ft)	Baseline Construction Cost (\$)	Estimated Construction Cost ⁽²⁾ (\$)	Capital Improvement Cost ⁽³⁾ (\$)	Project Schedule
Pipe for Renaissance Ranch Commerce Center	0	4	New	3,019	\$ 240	\$ 725,000	\$ 870,000	\$ 1,218,000	2025-2030
Pipe for JBJ Ranch	0	6	New	3,938	\$ 310	\$ 1,221,000	\$ 1,465,000	\$ 2,051,000	2025-2030
Pipe for Saddleback Estates	0	6	New	1,306	\$ 310	\$ 405,000	\$ 486,000	\$ 680,000	2025-2030
Pipe for SAM	0	6	New	3,513	\$ 310	\$ 1,089,000	\$ 1,307,000	\$ 1,830,000	2025-2030
Total Pipe		Varies		11,776					

Notes:

- (1) ENR 20 City Average Construction Cost Index for February 2023 is 14,033
- (2) Estimated Construction Cost includes a 20% contingency of the baseline construction cost.
- (3) Total project costs includes a 40% markup for engineering, construction management and environmental & legal and a 8% markup for project administration of the estimated construction cost.

Project Cost Allocation:

Reimbursement Category	Percent	Cost (\$)
Existing Users	0%	\$ -
Future Users	100%	\$ 5,779,000
Total	100%	\$ 5,779,000

Notes on Cost Estimation:

This project is an future improvement therefore 100% of cost are assigned to future users.

Project Detail:

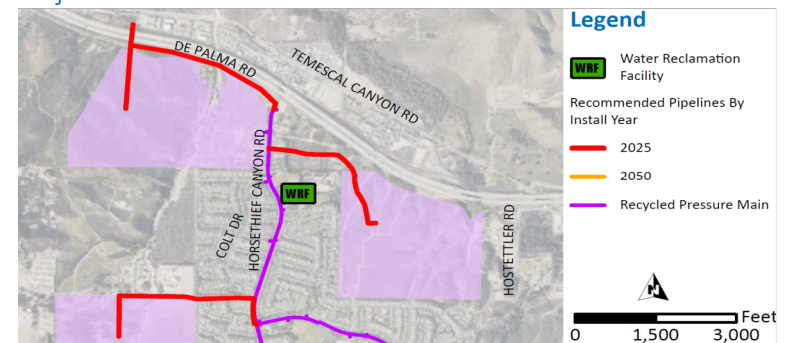

Project Number:	RWLP-2
Project Name:	Horsethief Long term new developments
System Type:	Recycled Water

Project Description:

This project includes construction of 4-inch pipelines for following two developments in the long-term:
 1. Sycamore Creek Marketplace
 2. Horsethief Ridge Tr 37002

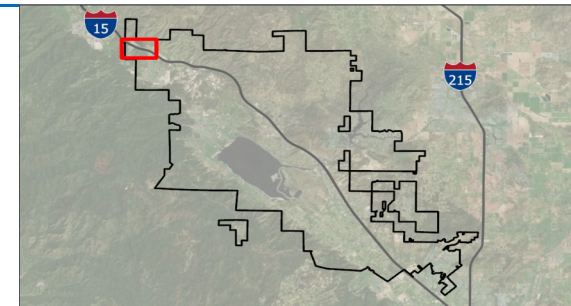

Project Details:

Project Element	Existing Diameter (in)	Proposed Diameter (in)	Replace/ New	Length (ft)	Unit Cost ⁽¹⁾ (\$/ft)	Baseline Construction Cost (\$)	Estimated Construction Cost ⁽²⁾ (\$)	Capital Improvement Cost ⁽³⁾ (\$)	Project Schedule
Pipe for Sycamore Marketplace	0	4	New	4,743	\$ 240	\$ 1,138,000	\$ 1,366,000	\$ 1,912,000	2040-2045
Pipe for Horsethief Ridge Tr 37002	0	4	New	685	\$ 240	\$ 164,000	\$ 197,000	\$ 276,000	2040-2045
Total Pipe		4		5,428					

Notes:

- (1) ENR 20 City Average Construction Cost Index for February 2023 is 14,033
- (2) Estimated Construction Cost includes a 20% contingency of the baseline construction cost.
- (3) Total project costs includes a 4.0% markup for engineering, construction management and environmental & legal and a 8% markup for project administration of the estimated construction cost.

Project Cost Allocation:

Reimbursement Category	Percent	Cost (\$)
Existing Users	0%	\$ -
Future Users	100%	\$ 2,188,000
Total	100%	\$ 2,188,000

Notes on Cost Estimation:

This project is an future improvement therefore 100% of cost are assigned to future users.

Project Detail:

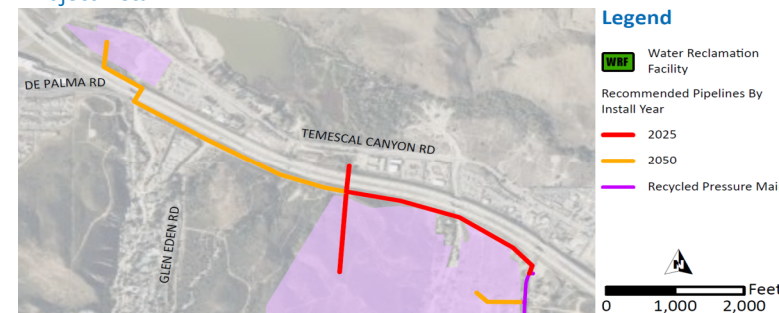

Project Number:	RW_IPR
Project Name:	Regional IPR with Injection Wells
System Type:	Recycled Water

Project Description:

This project includes construction of five new IPR injection wells. Three of the wells will begin operation in 2030 with a volume of 3,375 AFY. The remaining two wells will begin operation in 2036 with a volume of 6,750 AFY. The cost for this project is calculated by escalating the costs from the EVMWD, Final Indirect Potable Reuse Feasibility Study completed by Kennedy/Jenkins Consultants in 2016. An ENR Average Construction cost index for February 2023 is 14,033 which has been used to escalate the costs from the previous report.

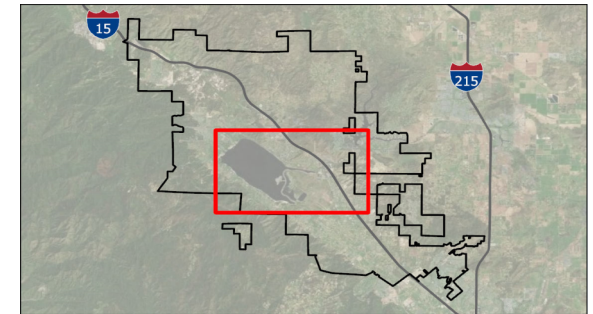

Project Details:

Project Element	Existing Diameter (in)	Proposed Diameter (in)	Replace/ New	Length (ft)	Unit Cost ⁽¹⁾ (\$/ft)	Baseline Construction Cost (\$)	Estimated Construction Cost ⁽²⁾ (\$)	Capital Improvement Cost ⁽³⁾ (\$)	Project Schedule
Phase I IPR with Injection Wells	-	-	New	-	\$ 62,034,059	\$ 62,034,000	\$ 74,441,000	\$ 104,217,000	2030-2035
Phase II IPR with Injection Wells	-	-	New	-	\$ 34,614,190	\$ 34,614,000	\$ 41,537,000	\$ 58,152,000	2035-2040

Notes:

- (1) ENR 20 City Average Construction Cost Index for February 2023 is 14,033
- (2) Estimated Construction Cost includes a 20% contingency of the baseline construction cost.
- (3) Total project costs includes a 40% markup for engineering, construction management and environmental & legal and a 8% markup for project administration of the estimated construction cost.

Project Cost Allocation:

Reimbursement Category	Percent	Cost (\$)
Existing Users	0%	\$ -
Future Users	100%	\$ 162,369,000
Total	100%	\$ 162,369,000

Notes on Cost Estimation:

This project is an future improvement therefore 100% of cost are assigned to future users.

Project Detail:

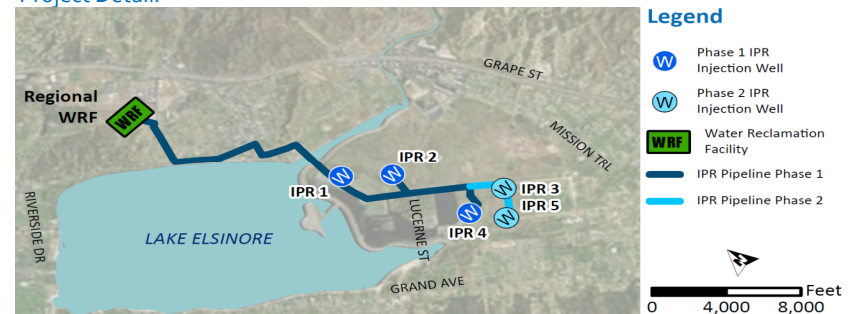

Project Number:	RWPS-1
Project Name:	Horsethief 1 Pump Station Upgrade
System Type:	Recycled Water

Project Description:

Adding a new pump at the Horsethief 1 pump station to provide MDD and PHD for short term and long term improvements.

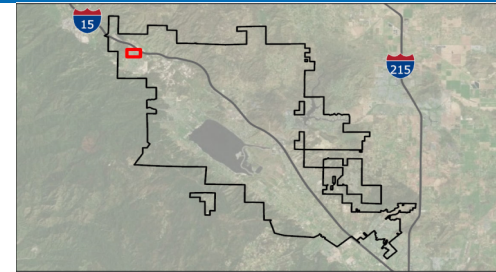

Project Details:

Project Element	Existing Firm Capacity (gpm)	Proposed Firm Capacity (gpm)	Replace/ New	Total gpm	Unit Cost ⁽¹⁾ (\$/gpm)	Baseline Construction Cost (\$)	Estimated Construction Cost ⁽²⁾ (\$)	Capital Improvement Cost ⁽³⁾ (\$)	Project Schedule
Additional Pump	0.00	295	Expansion	327	\$ 1,500,000	\$ 1,500,000	\$ 1,800,000	\$ 2,520,000	2025-2030

Notes:

- (1) ENR 20 City Average Construction Cost Index for February 2023 is 14,033
- (2) Estimated Construction Cost includes a 20% contingency of the baseline construction cost.
- (3) Total project costs includes a 40% markup for engineering, construction management and environmental & legal and a 8% markup for project administration of the estimated construction cost.

Project Cost Allocation:

Reimbursement Category	Percent	Cost (\$)
Existing Users	100%	\$ 2,520,000
Future Users	0%	\$ -
Total	100%	\$ 2,520,000

Notes on Cost Estimation:

This project is an existing improvement therefore 100% of cost are assigned to existing users.

Project Detail:



Project Number:	RWPS-2
Project Name:	Replacing pumps based on age
System Type:	Recycled Water

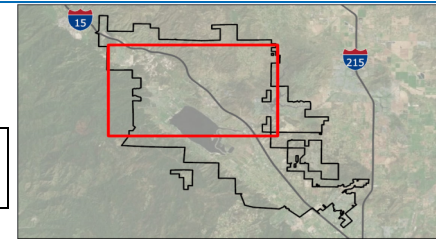

Project Description:

This project would replace the pumps in the system based on their age. The life span of a pump is assumed to be 20 years. The three pumps serving the Cottonwood community were installed in 2002 and need to be replaced in the near future. The remaining two pumps serving the CLGC were installed in 1985 and are past their useful life and will need to be replaced.

Project Details:

Project Element	Existing Power (hp)	Proposed Power (hp)	Replace/ New	Total gpm	Unit Cost ⁽¹⁾ (\$/gpm)	Baseline Construction Cost (\$)	Estimated Construction Cost ⁽²⁾ (\$)	Capital Improvement Cost ⁽³⁾ (\$)	Project Schedule
Cottonwood Hills Pump 1	60	60	Replace	400	\$ 60,000	\$ 60,000	\$ 72,000	\$ 101,000	2023-2025
Cottonwood Hills Pump 2	60	60	Replace	400	\$ 60,000	\$ 60,000	\$ 72,000	\$ 101,000	2023-2025
Cottonwood Hills Pump 3	60	60	Replace	400	\$ 60,000	\$ 60,000	\$ 72,000	\$ 101,000	2023-2025
Canyon Lake Golf Course Pump 1	40	40	Replace	700	\$ 40,000	\$ 40,000	\$ 48,000	\$ 67,000	2023-2025
Canyon Lake Golf Course Pump 2	40	40	Replace	700	\$ 40,000	\$ 40,000	\$ 48,000	\$ 67,000	2023-2025
Cottonwood Hills Pump 1	60	60	Replace	400	\$ 60,000	\$ 60,000	\$ 72,000	\$ 101,000	2040-2045
Cottonwood Hills Pump 2	60	60	Replace	400	\$ 60,000	\$ 60,000	\$ 72,000	\$ 101,000	2040-2045
Cottonwood Hills Pump 3	60	60	Replace	400	\$ 60,000	\$ 60,000	\$ 72,000	\$ 101,000	2040-2045
Canyon Lake Golf Course Pump 1	40	40	Replace	700	\$ 40,000	\$ 40,000	\$ 48,000	\$ 67,000	2040-2045
Canyon Lake Golf Course Pump 2	40	40	Replace	700	\$ 40,000	\$ 40,000	\$ 48,000	\$ 67,000	2040-2045
Horsethief 1 Pump 1 (at HTCWRF)	40	40	Replace	334	\$ 40,000	\$ 40,000	\$ 48,000	\$ 67,000	2025-2030
Horsethief 1 Pump 2 (at HTCWRF)	40	40	Replace	334	\$ 40,000	\$ 40,000	\$ 48,000	\$ 67,000	2025-2030
Horsethief 2 Pump 1 (Mid-Range)	40	40	Replace	334	\$ 40,000	\$ 40,000	\$ 48,000	\$ 67,000	2025-2030
Horsethief 2 Pump 2 (Mid-Range)	40	40	Replace	334	\$ 40,000	\$ 40,000	\$ 48,000	\$ 67,000	2025-2030
Horsethief 2 Pump 3 (Mid-Range)	40	40	Replace	334	\$ 40,000	\$ 40,000	\$ 48,000	\$ 67,000	2025-2030
Horsethief 1 Pump 1 (at HTCWRF)	40	40	Replace	334	\$ 40,000	\$ 40,000	\$ 48,000	\$ 67,000	2045-2050
Horsethief 1 Pump 2 (at HTCWRF)	40	40	Replace	334	\$ 40,000	\$ 40,000	\$ 48,000	\$ 67,000	2045-2050
Horsethief 2 Pump 1 (Mid-Range)	40	40	Replace	334	\$ 40,000	\$ 40,000	\$ 48,000	\$ 67,000	2045-2050
Horsethief 2 Pump 2 (Mid-Range)	40	40	Replace	334	\$ 40,000	\$ 40,000	\$ 48,000	\$ 67,000	2045-2050
Horsethief 2 Pump 3 (Mid-Range)	40	40	Replace	334	\$ 40,000	\$ 40,000	\$ 48,000	\$ 67,000	2045-2050
New Pump at Horsethief 1 PS (at HTCWRF)	40	40	Replace	295	\$ 40,000	\$ 40,000	\$ 48,000	\$ 67,000	2045-2050

Notes:

- (1) ENR 20 City Average Construction Cost Index for February 2023 is 14,033
- (2) Estimated Construction Cost includes a 20% contingency of the baseline construction cost.
- (3) Total project costs includes a 40% markup for engineering, construction management and environmental & legal and a 8% markup for project administration of the estimated construction cost.

Project Cost Allocation:

Reimbursement Category	Percent	Cost (\$)
Existing Users	50%	\$ 805,500
Future Users	50%	\$ 805,500
Total	100%	\$ 1,611,000

Notes on Cost Estimation:

This project is an existing improvement therefore 100% of cost are assigned to existing users.

Project Detail:



Project Number:	RWST-1
Project Name:	New Storage Tank for Horsethief 1844 zone
System Type:	Recycled Water

Project Description:

Storage tank for Horsethief 1844 zone

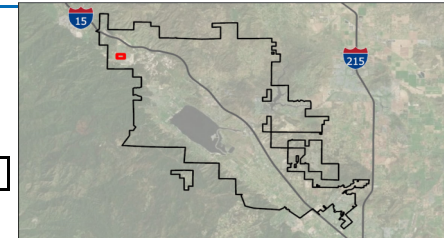

Project Details:

Project Element	Existing Capacity (MG)	Proposed Capacity (MG)	Replace/ New	Proposed Capacity (gal)	Unit Cost ⁽¹⁾ (\$/gal)	Baseline Construction Cost (\$)	Estimated Construction Cost ⁽²⁾ (\$)	Capital Improvement Cost ⁽³⁾ (\$)	Project Schedule
Horsethief 1844 Zone Storage Tank	0.00	0.068	New	68,000	\$ 2.70	\$ 184,000	\$ 221,000	\$ 309,000	2025-2030

Notes:

- (1) ENR 20 City Average Construction Cost Index for February 2023 is 14,033
- (2) Estimated Construction Cost includes a 20% contingency of the baseline construction cost.
- (3) Total project costs includes a 40% markup for engineering, construction management and environmental & legal and a 8% markup for project administration of the estimated construction cost.

Project Cost Allocation:

Reimbursement Category	Percent	Cost (\$)
Existing Users	0%	\$ -
Future Users	100%	\$ 309,000
Total	100%	\$ 309,000

Notes on Cost Estimation:

This project is an existing improvement therefore 100% of cost are assigned to existing users.

Project Detail:

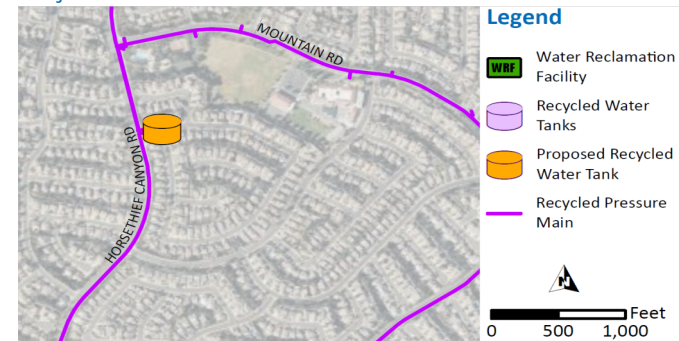

Appendix G
NON-CIP PROJECTS SUMMARY SHEETS

Project Number:	RWLP-4
Project Name:	Wildomar NPR Project 1
System Type:	Recycled Water

Project Description:

This project includes construction of 4-inch, 6-inch and 12-inch pipelines for following developments:

1. Hidden Spring Mixed Use
2. Clinton Keith MSJC College Campus
3. Rancon Medical & educational Center
4. Inland Valley Medical Center
5. Horizon Condos TR 36672
6. Hotel at Oak Creek Shopping Center
7. Westpark
8. Oak Springs Ranch Ph. 2
9. Prielipp Apartments
10. Grove PArk
11. Villa Sienna

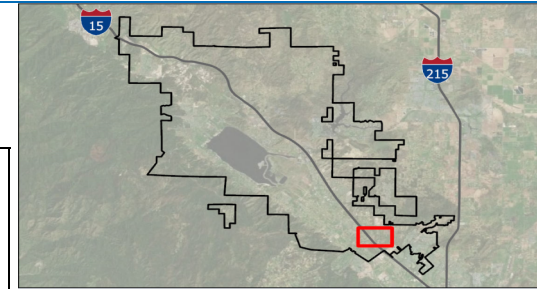

Project Details:

Project Element	Existing Diameter (in)	Proposed Diameter (in)	Replace/ New	Length (ft)	Unit Cost ⁽¹⁾ (\$/ft)	Baseline Construction Cost (\$)	Estimated Construction Cost ⁽²⁾ (\$)	Capital Improvement Cost ⁽³⁾ (\$)	Project Schedule
Pipe for Wildomar NPR Project 1	0	4	New	15,632	\$ 240	\$ 3,752,000	\$ 4,502,000	\$ 6,303,000	2040-2045
Pipe for Wildomar NPR Project 1	0	6	New	378	\$ 310	\$ 117,000	\$ 140,000	\$ 197,000	2040-2045
Pipe for Wildomar NPR Project 1	0	12	New	7,950	\$ 390	\$ 3,101,000	\$ 3,721,000	\$ 5,210,000	2040-2046
Total Pipe		Varies		23,960					

Notes:

- (1) ENR 20 City Average Construction Cost Index for February 2023 is 14,033
- (2) Estimated Construction Cost includes a 20% contingency of the baseline construction cost.
- (3) Total project costs includes a 40% markup for engineering, construction management and environmental & legal and a 8% markup for project administration of the estimated construction cost.

Project Cost Allocation:

Reimbursement Category	Percent	Cost (\$)
Existing Users	0%	\$ -
Future Users	100%	\$ 11,710,000
Total	100%	\$ 11,710,000

Notes on Cost Estimation:

This project is an future improvement therefore 100% of cost are assigned to future users.

Project Detail:

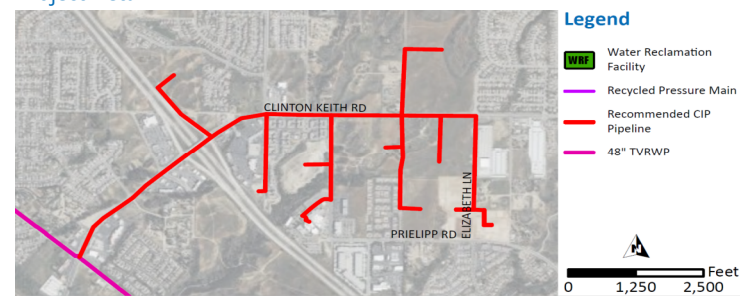

Project Number:	RWLP-5
Project Name:	Wildomar NPR Project 2
System Type:	Recycled Water

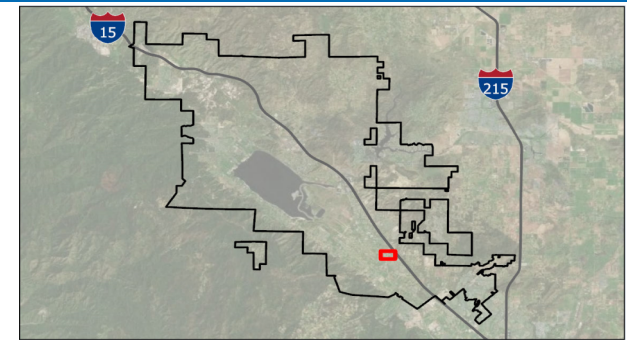

Project Description:

This project includes construction of 4-inch pipelines for following developments:

1. Baxter Village
2. Baxter & I-15 Mixed Use Project

Project Details:

Project Element	Existing Diameter (in)	Proposed Diameter (in)	Replace/ New	Length (ft)	Unit Cost ⁽¹⁾ (\$/ft)	Baseline Construction Cost (\$)	Estimated Construction Cost ⁽²⁾ (\$)	Capital Improvement Cost ⁽³⁾ (\$)	Project Schedule
Pipe for Wildomar NPR Project 2	0	4	New	2,467	\$ 240	\$ 592,000	\$ 710,000	\$ 995,000	2040-2045
Total Pipe		Varies		2,467					

Notes:

- (1) ENR 20 City Average Construction Cost Index for February 2023 is 14,033
- (2) Estimated Construction Cost includes a 20% contingency of the baseline construction cost.
- (3) Total project costs includes a 40% markup for engineering, construction management and environmental & legal and a 8% markup for project administration of the estimated construction cost.

Project Cost Allocation:

Reimbursement Category	Percent	Cost (\$)
Existing Users	0%	\$ -
Future Users	100%	\$ 995,000
Total	100%	\$ 995,000

Notes on Cost Estimation:

This project is an future improvement therefore 100% of cost are assigned to future users.

Project Detail:



Project Number:	RWLP-6
Project Name:	Wildomar NPR Project 3
System Type:	Recycled Water

Project Description:

This project includes construction of 4-inch pipelines for following development:
 1. Orange St. Water & Sewer Improvements

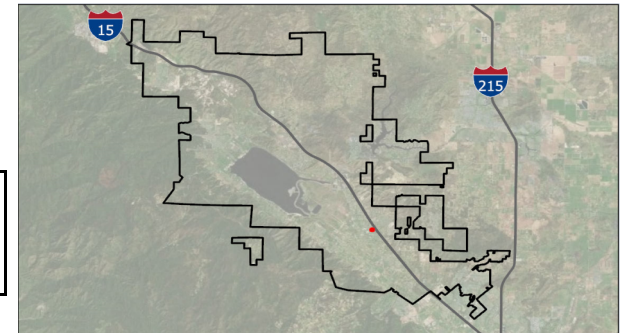

Project Details:

Project Element	Existing Diameter (in)	Proposed Diameter (in)	Replace/ New	Length (ft)	Unit Cost ⁽¹⁾ (\$/ft)	Baseline Construction Cost (\$)	Estimated Construction Cost ⁽²⁾ (\$)	Capital Improvement Cost ⁽³⁾ (\$)	Project Schedule
Pipe for Wildomar NPR Project 3	0	4	New	314	\$ 240	\$ 75,000	\$ 90,000	\$ 126,000	2040-2045
Total Pipe		Varies		314					

Notes:

- (1) ENR 20 City Average Construction Cost Index for February 2023 is 14,033
- (2) Estimated Construction Cost includes a 20% contingency of the baseline construction cost.
- (3) Total project costs includes a 4.0% markup for engineering, construction management and environmental & legal and a 8% markup for project administration of the estimated construction cost.

Project Cost Allocation:

Reimbursement Category	Percent	Cost (\$)
Existing Users	0%	\$ -
Future Users	100%	\$ 126,000
Total	100%	\$ 126,000

Notes on Cost Estimation:

This project is an future improvement therefore 100% of cost are assigned to future users.

Project Detail:

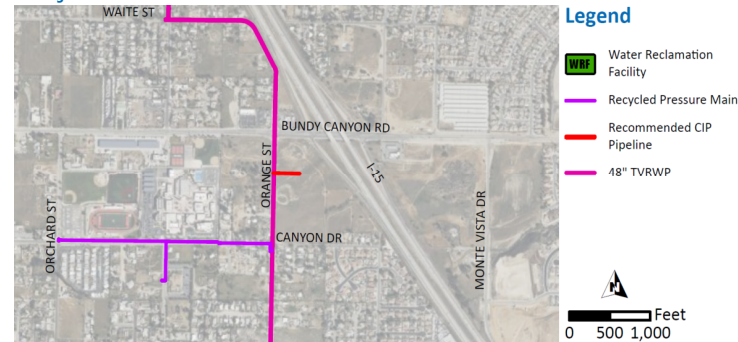

Project Number:	RWLP-7
Project Name:	Wildomar NPR Project 4
System Type:	Recycled Water

Project Description:

This project includes construction of 4-inch and 6-inch pipelines for following developments:

1. Won Meditation/Retreat Center
2. 94 Unit Apartments on Corydon & Sheets Ln
3. Corydon & Grand Mixed Use- APN 370-171-015

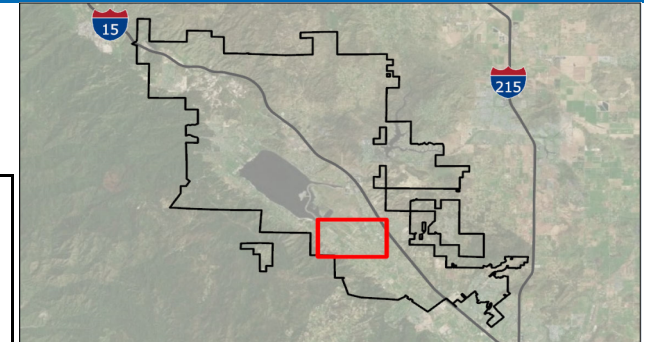

Project Details:

Project Element	Existing Diameter (in)	Proposed Diameter (in)	Replace/ New	Length (ft)	Unit Cost ⁽¹⁾ (\$/ft)	Baseline Construction Cost (\$)	Estimated Construction Cost ⁽²⁾ (\$)	Capital Improvement Cost ⁽³⁾ (\$)	Project Schedule
Pipe for Wildomar NPR Project 4	0	4	New	9,270	\$ 240	\$ 2,225,000	\$ 2,670,000	\$ 3,738,000	2040-2045
Pipe for Wildomar NPR Project 4	0	6	New	2,270	\$ 310	\$ 704,000	\$ 845,000	\$ 1,183,000	2040-2045
Total Pipe		Varies		11,540					

Notes:

- (1) ENR 20 City Average Construction Cost Index for February 2023 is 14,033
- (2) Estimated Construction Cost includes a 20% contingency of the baseline construction cost.
- (3) Total project costs includes a 40% markup for engineering, construction management and environmental & legal and a 8% markup for project administration of the estimated construction cost.

Project Cost Allocation:

Reimbursement Category	Percent	Cost (\$)
Existing Users	0%	\$ -
Future Users	100%	\$ 4,921,000
Total	100%	\$ 4,921,000

Notes on Cost Estimation:

This project is an future improvement therefore 100% of cost are assigned to future users.

Project Detail:



Project Number:	RWLP-8
Project Name:	Wildomar NPR Project 5
System Type:	Recycled Water

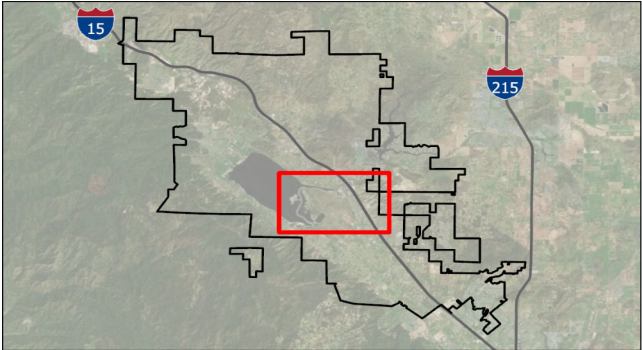

Project Description:

This project includes construction of 4-inch pipelines for following developments:

1. Lake Elsinore Commerce Center
2. Canyon Hills Ph. & Landscape
3. Greenspring Hotel
4. Artisan Alley

Project Details:

Project Element	Existing Diameter (in)	Proposed Diameter (in)	Replace/ New	Length (ft)	Unit Cost ⁽¹⁾ (\$/ft)	Baseline Construction Cost (\$)	Estimated Construction Cost ⁽²⁾ (\$)	Capital Improvement Cost ⁽³⁾ (\$)	Project Schedule
Pipe for Wildomar NPR Project 5	0	4	New	7,054	\$ 240	\$ 1,693,000	\$ 2,032,000	\$ 2,844,000	2040-2045
Total Pipe		Varies		7,054					

Notes:

- (1) ENR 20 City Average Construction Cost Index for February 2023 is 14,033
- (2) Estimated Construction Cost includes a 20% contingency of the baseline construction cost.
- (3) Total project costs includes a 40% markup for engineering, construction management and environmental & legal and a 8% markup for project administration of the estimated construction cost.

Project Cost Allocation:

Reimbursement Category	Percent	Cost (\$)
Existing Users	0%	\$ -
Future Users	100%	\$ 2,844,000
Total	100%	\$ 2,844,000

Notes on Cost Estimation:

This project is an future improvement therefore 100% of cost are assigned to future users.

Project Detail:



Project Number:	RWLP-9
Project Name:	Regional NPR Project 1
System Type:	Recycled Water

Project Description:

This project includes construction of 6-inch, 24-inch and 36-inch pipelines for following developments:

1. The Cove Apartments
2. Walmart Shopping Center, Inc.
3. Hwy 74 Contractor Yard
4. La Quinta Hotel on Dexter Ave.
5. Central Grocery and Retail
6. Collier Honda Dealership
7. Lake Elsinore Commercial
8. Elsinore Valley Cemetery

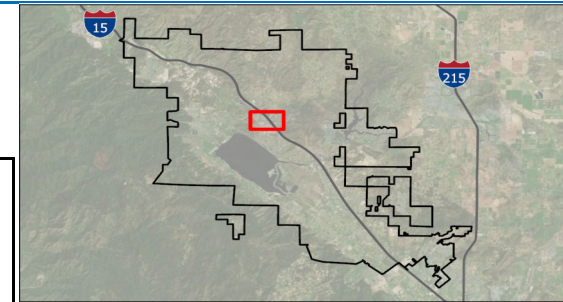

Project Details:

Project Element	Existing Diameter (in)	Proposed Diameter (in)	Replace/ New	Length (ft)	Unit Cost ⁽¹⁾ (\$/ft)	Baseline Construction Cost (\$)	Estimated Construction Cost ⁽²⁾ (\$)	Capital Improvement Cost ⁽³⁾ (\$)	Project Schedule
Pipe for Regional NPR Project 1	0	6	New	7,177	\$ 240	\$ 1,722,000	\$ 2,066,000	\$ 2,893,000	2040-2045
Pipe for Regional NPR Project 1	0	20	New	3,162	\$ 570	\$ 1,802,000	\$ 2,162,000	\$ 3,027,000	2040-2045
Pipe for Regional NPR Project 1	0	24	New	2,636	\$ 630	\$ 1,661,000	\$ 1,993,000	\$ 2,790,000	2040-2045
Total Pipe		Varies		12,975					

Notes:

- (1) ENR 20 City Average Construction Cost Index for February 2023 is 14,033
- (2) Estimated Construction Cost includes a 20% contingency of the baseline construction cost.
- (3) Total project costs includes a 40% markup for engineering, construction management and environmental & legal and a 8% markup for project administration of the estimated construction cost.

Project Cost Allocation:

Reimbursement Category	Percent	Cost (\$)
Existing Users	0%	\$ -
Future Users	100%	\$ 8,710,000
Total	100%	\$ 8,710,000

Notes on Cost Estimation:

This project is an future improvement therefore 100% of cost are assigned to future users.

Project Detail:



Project Number:	RWLP-10
Project Name:	Regional NPR Project 2
System Type:	Recycled Water

Project Description:

This project includes construction of 6-inch, 12-inch and 20-inch pipelines for following developments:

1. Hoist Industrial
2. Marriott Hotel
3. Nichols Industrial Center
4. Alberhill Ranch

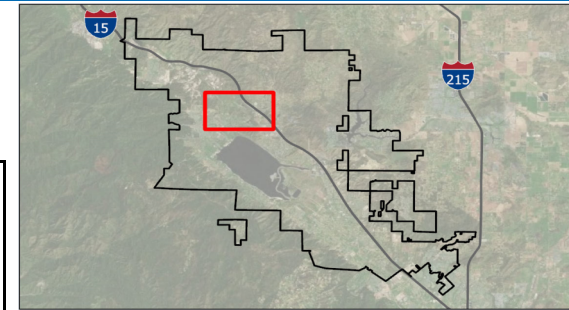

Project Details:

Project Element	Existing Diameter (in)	Proposed Diameter (in)	Replace/ New	Length (ft)	Unit Cost ⁽¹⁾ (\$/ft)	Baseline Construction Cost (\$)	Estimated Construction Cost ⁽²⁾ (\$)	Capital Improvement Cost ⁽³⁾ (\$)	Project Schedule
Pipe for Regional NPR Project 2	0	6	New	794	\$ 310	\$ 246,000	\$ 295,000	\$ 413,000	2040-2045
Pipe for Regional NPR Project 2	0	12	New	18,136	\$ 390	\$ 7,073,000	\$ 8,488,000	\$ 11,883,000	2040-2045
Pipe for Regional NPR Project 3	0	16	New	5,864	\$ 470	\$ 2,756,000	\$ 3,307,000	\$ 4,630,000	2040-2045
Total Pipe		Varies		24,794					

Notes:

- (1) ENR 20 City Average Construction Cost Index for February 2023 is 14,033
- (2) Estimated Construction Cost includes a 20% contingency of the baseline construction cost.
- (3) Total project costs includes a 40% markup for engineering, construction management and environmental & legal and a 8% markup for project administration of the estimated construction cost.

Project Cost Allocation:

Reimbursement Category	Percent	Cost (\$)
Existing Users	0%	\$ -
Future Users	100%	\$ 16,926,000
Total	100%	\$ 16,926,000

Notes on Cost Estimation:

This project is an future improvement therefore 100% of cost are assigned to future users.

Project Detail:



Project Number:	RWLP-11
Project Name:	Regional NPR Project 3
System Type:	Recycled Water

Project Description:

This project includes building of 6-inch pipelines for following developments:

1. La Laguna RV Residential Lot
2. Lakeside Pointe Apartments
3. Lakeview Manor
4. Riverside Dr. Lake Front Hotel- Mixed Use

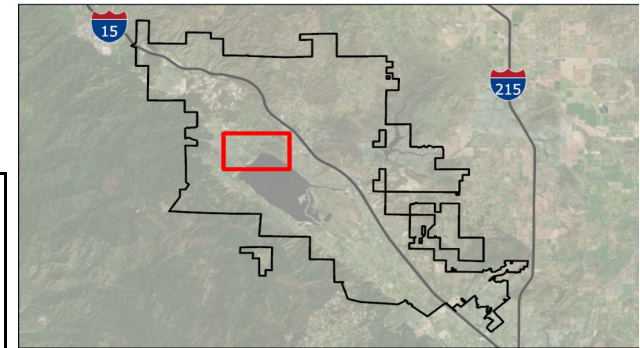

Project Details:

Project Element	Existing Diameter (in)	Proposed Diameter (in)	Replace/ New	Length (ft)	Unit Cost ⁽¹⁾ (\$/ft)	Baseline Construction Cost (\$)	Estimated Construction Cost ⁽²⁾ (\$)	Capital Improvement Cost ⁽³⁾ (\$)	Project Schedule
Pipe for Regional NPR Project 3	0	6	New	9,250	\$ 310	\$ 2,868,000	\$ 3,442,000	\$ 4,818,000	2040-2045
Pipe for Regional NPR Project 3	0	12	New	9,281	\$ 390	\$ 3,620,000	\$ 4,344,000	\$ 6,082,000	2040-2045
Total Pipe		Varies		18,531					

Notes:

- (1) ENR 20 City Average Construction Cost Index for February 2023 is 14,033
- (2) Estimated Construction Cost includes a 20% contingency of the baseline construction cost.
- (3) Total project costs includes a 40% markup for engineering, construction management and environmental & legal and a 8% markup for project administration of the estimated construction cost.

Project Cost Allocation:

Reimbursement Category	Percent	Cost (\$)
Existing Users	0%	\$ -
Future Users	100%	\$ 10,900,000
Total	100%	\$ 10,900,000

Notes on Cost Estimation:

This project is an future improvement therefore 100% of cost are assigned to future users.

Project Detail:



Project Number:	RWPS-3
Project Name:	New Booster Pump Stations
System Type:	Regional System Recycled Water

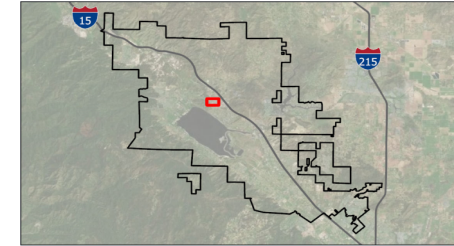

Project Description:

This project would install three new booster pump stations that will be required for a potential Regional NPR system.

Project Details:

Project Element	Replace/ New	Total gpm	Unit Cost ⁽¹⁾ (\$/gpm)	Baseline Construction Cost (\$)	Estimated Construction Cost ⁽²⁾ (\$)	Capital Improvement Cost ⁽³⁾ (\$)	Project Schedule
Pump station at Regional WRF	New	8,500	\$ 7,750,000	\$ 7,750,000	\$ 9,300,000	\$ 13,020,000	2040-2045
Pump station along 3rd street NE of Conrad Ave.	New	400	\$ 1,500,000	\$ 1,500,000	\$ 1,800,000	\$ 2,520,000	2040-2045
Pump Station at Baker Street	New	2,000	\$ 3,500,000	\$ 3,500,000	\$ 4,200,000	\$ 5,880,000	2040-2045

Notes:

- (1) ENR 20 City Average Construction Cost Index for February 2023 is 14,033
- (2) Estimated Construction Cost includes a 20% contingency of the baseline construction cost.
- (3) Total project costs includes a 4.0% markup for engineering, construction management and environmental & legal and a 8% markup for project administration of the estimated construction cost.

Project Cost Allocation:

Reimbursement Category	Percent	Cost (\$)
Existing Users	0%	\$ -
Future Users	100%	\$ 21,420,000
Total	100%	\$ 21,420,000

Notes on Cost Estimation:

This project is an future improvement therefore 100% of cost are assigned to future users.

Project Detail:

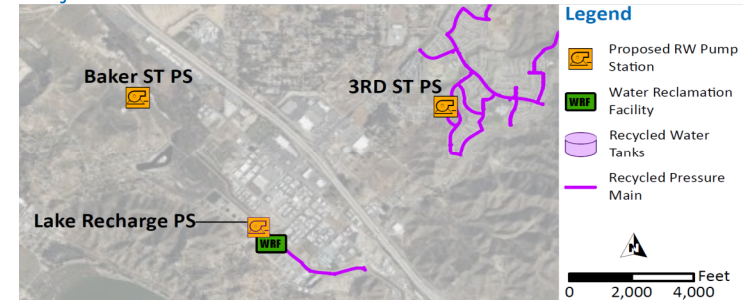

Project Number:	RWST-2
Project Name:	New Storage Tank for Regional NPW Expansion
System Type:	Recycled Water

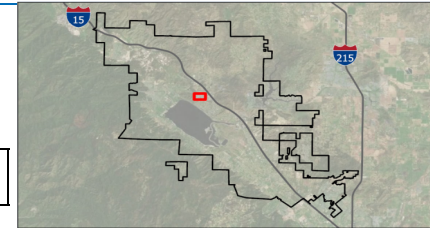

Project Description:

This project involves the construction of a new storage tank at the Regional WRF that would be needed for the expansion of the Regional Plant.

Project Details:

Project Element	Existing Capacity (MG)	Proposed Capacity (MG)	Replace/ New	Proposed Capacity (gal)	Unit Cost ⁽¹⁾ (\$/gal)	Baseline Construction Cost (\$)	Estimated Construction Cost ⁽²⁾ (\$)	Capital Improvement Cost ⁽³⁾ (\$)	Project Schedule
Regional WRF Storage Tank	0.00	1.400	New	1,400,000	\$ 2.55	\$ 3,570,000	\$ 4,284,000	\$ 5,998,000	2040-2045

Notes:

- (1) ENR 20 City Average Construction Cost Index for February 2023 is 14,033
- (2) Estimated Construction Cost includes a 20% contingency of the baseline construction cost.
- (3) Total project costs includes a 40% markup for engineering, construction management and environmental & legal and a 8% markup for project administration of the estimated construction cost.

Project Cost Allocation:

Reimbursement Category	Percent	Cost (\$)
Existing Users	0%	\$ -
Future Users	100%	\$ 5,998,000
Total	100%	\$ 5,998,000

Notes on Cost Estimation:

This project is an existing improvement therefore 100% of cost are assigned to existing users.

Project Detail:

