

TYPICAL LATERAL ASSEMBLY

NOTE: NO TREES OR LARGE SHRUBS SHALL BE LOCATED WITHIN 10 FEET OF ALL PUBLIC SEWER FACILITIES (PIPE, LATERALS, MANHOLES, CLEANOUTS, ETC.).

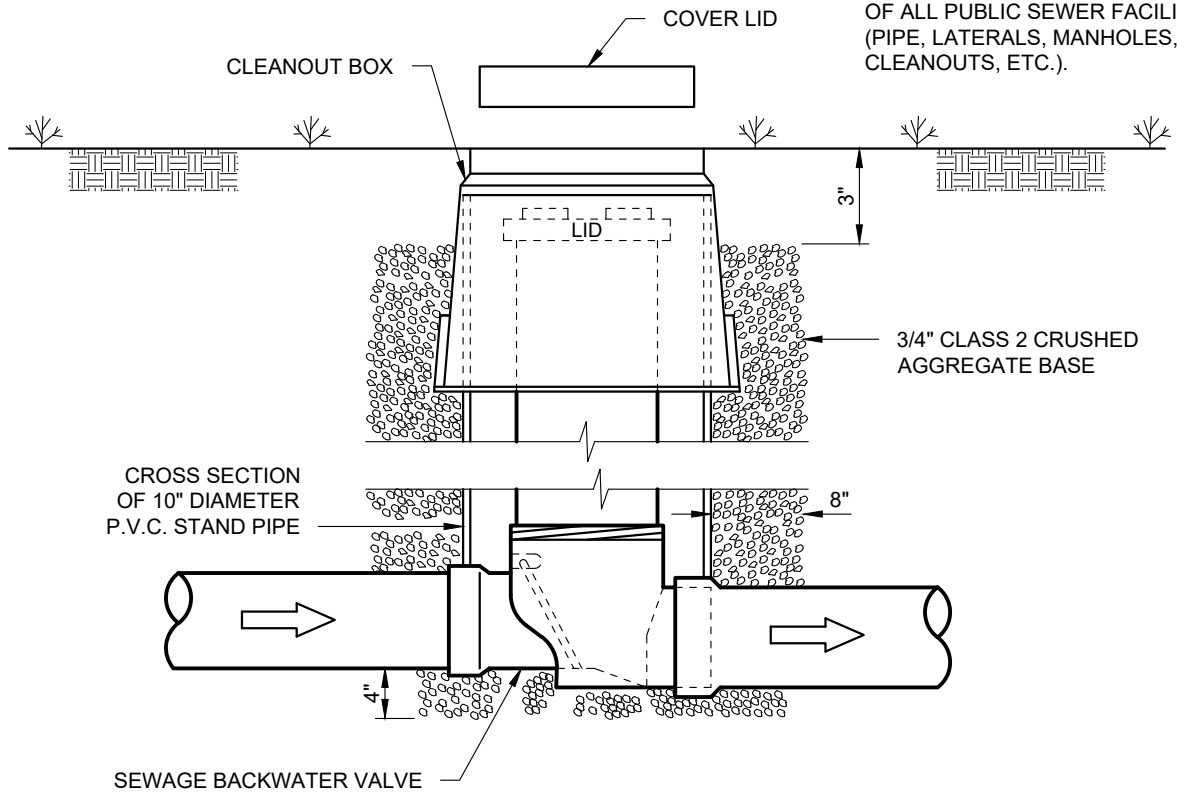

DETAIL "A" - SEWAGE BACKWATER VALVE ASSEMBLY

REVISION	BY	APPR	DATE
CLEANOUT SETBACK	AK	JZ	01-22-24

ELSINORE VALLEY
MUNICIPAL WATER DISTRICT

06/22/2023
PARAG KALARIA R.C.E. 83927 DATE

TYPICAL LATERAL ASSEMBLY & BACKWATER VALVE

STD. DWG. NO.
S-12