

NOTE: SYSTEM TO BE DESIGNED BY TIDEFLEX FOR EACH RESERVOIR APPLICATION

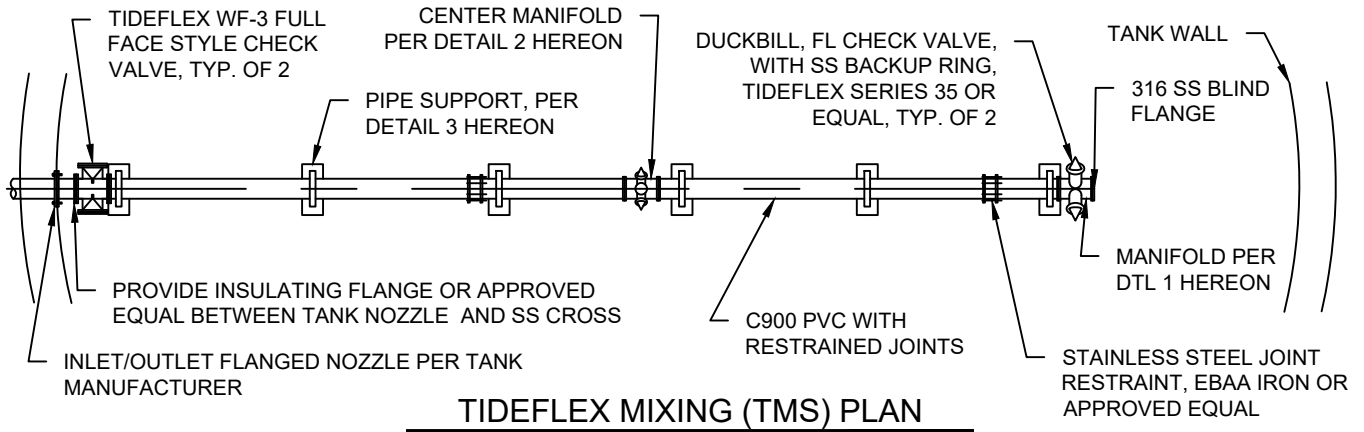

TIDEFLEX MIXING (TMS) PLAN

NTS

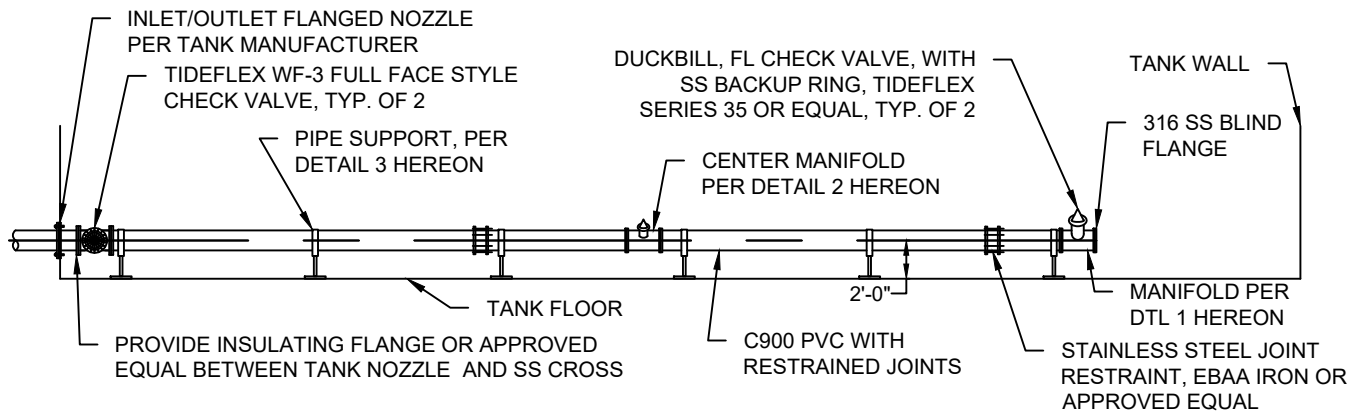

TIDEFLEX MIXING (TMS) ELEVATION

NTS

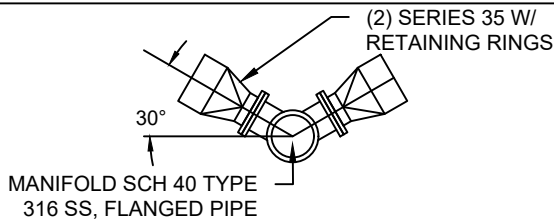

1 END MANIFOLD DETAIL
NOT TO SCALE

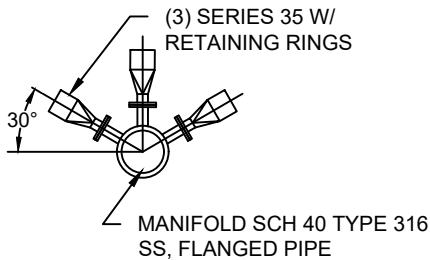

2 CENTER MANIFOLD DETAIL
NOT TO SCALE

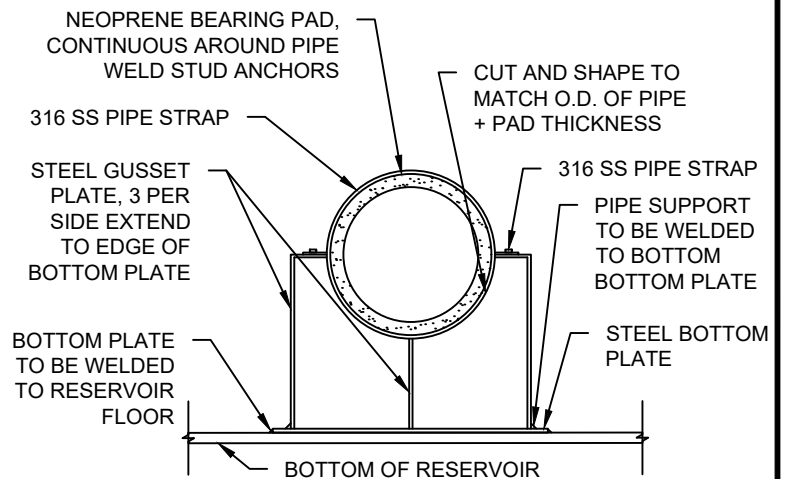

3 PIPE SUPPORT DETAIL
NOT TO SCALE

REVISION	BY	APPR	DATE

ELSINORE VALLEY
MUNICIPAL WATER DISTRICT
06/22/2023
PARAG KALARIA R.C.E. 83927 DATE

TIDEFLEX MIXING SYSTEM DETAILS

STD. DWG. NO.
T-10