

**PLAN**

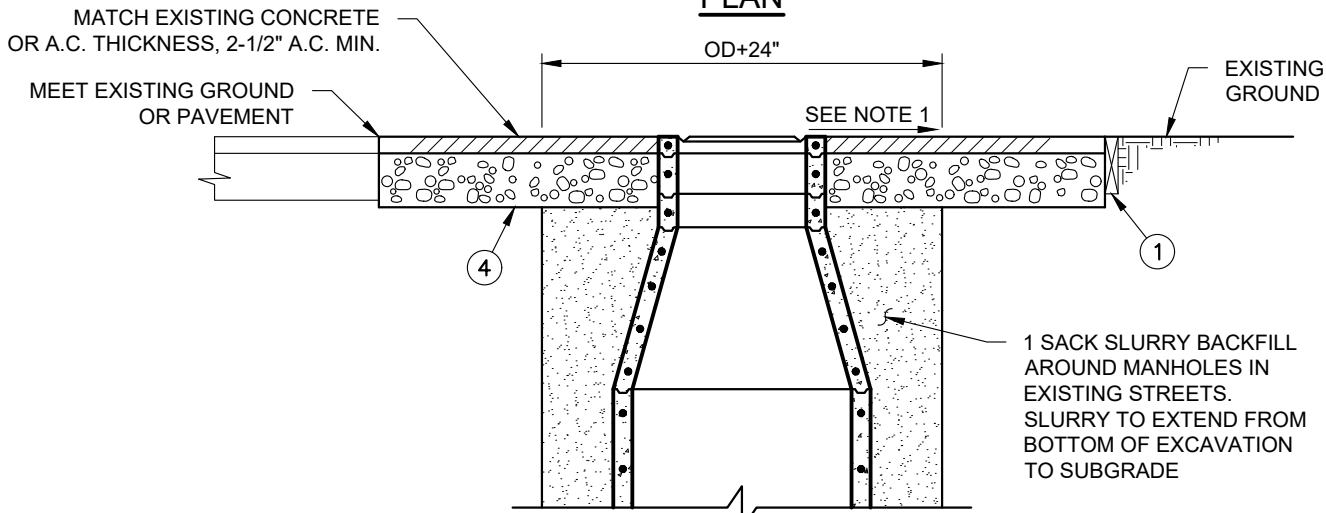

**SECTION A-A**

**NOTES:**

- 1. SLOPE WILL CONFORM TO RIVERSIDE COUNTY ROAD IMPROVEMENTS STANDARDS AND SPECIFICATIONS, OR MEET EXISTING CONDITIONS AS DIRECTED BY ENGINEER.
- 2. MATERIALS SHALL BE SELECTED FROM THE APPROVED MATERIALS LIST.

ITEM	DESCRIPTION
①	2"x6" REDWOOD HEADERS IF REQUIRED BY ENGINEER OR AS DIRECTED
②	2"x4"x18" STAKES (3 PER SIDE) AT 30" O.C.
③	AREA TO BE PAVED
④	6" OF 3/4" CLASS 2 CRUSHED AGGREGATE BASE

REVISION	BY	APPR	DATE

PARAG KALARIA R.C.E. 83927 DATE

**PAVING DETAIL  
AROUND MANHOLES**

STD. DWG. NO.  
**S-10**